

2020 Bridge Painting Program

P.I.N. 5762.92

Freedom Bridge No. 1, B.I.N. 3321510,
CR 21 - Delevan-Elton Road over South Branch Elton Creek
East Otto Bridge No. 27, B.I.N. 3321150,
Hammond Hill Road over Connoisarauley Creek
South Valley Bridge No. 4, B.I.N. 3323210,
County Road 33 over Bone Run

Cattaraugus County Department of Public Works

8810 Route 242
Little Valley, NY 14755

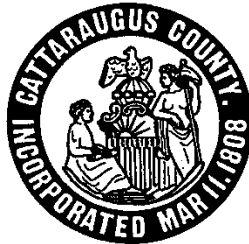

General Provisions and Proposal Booklet

February 2020

Prepared By:
Greenman-Pedersen, Inc.

CATTARAUGUS COUNTY DEPARTMENT OF PUBLIC WORKS

Instructions to Bidders.

Specifications and Related Documents

For

2020 Bridge Painting Program

P.I.N. 5762.92

Cattaraugus County Department of Public Works

8810 Route 242

Little Valley, New York 14755

Tel. (716) 938-9121

Fax (716) 938-2754



Glenn E. Blake

CATTARAUGUS COUNTY

DEPARTMENT OF PUBLIC WORKS

Development – Progress – Workmanship

Kathleen M. Ellis, Commissioner

Mark C. Burr, PE, Director of Engineering

Phone (716) 938 9121



8810 Route 242, Jack Ellis Drive

Little Valley, New York 14755

Fax (716) 938 2753

ADVERTISEMENT FOR BIDS

Sealed bids for **2020 Bridge Painting Program**, a federal-aid bridge maintenance program, according to specifications, will be received by the undersigned, at the Department of Public Works Facility, 8810 Route 242, Little Valley, New York, until **Wednesday, March 25, 2020 at 1:45 P.M.** after which they will be publicly opened at **2:00 P.M.** (at the **same location**), by the undersigned, under the direction of the Public Works Committee of the Cattaraugus County Legislature. Each bid, at the time it is received, will be stamped showing the date and time of receipt.

All bids must be sealed and clearly marked as follows:

DPW BID #29 - 2020 Bridge Painting Program

Copies of the proposed Contract Documents, Plans, Specifications and Instructions to Bidders will be available **Friday, February 28, 2020**, and may be secured electronically from Cattaraugus County Department of Public Works, 8810 Route 242, Little Valley, New York 14755, phone Dawn Smith at (716) 938-9121, Ext. 2465. The specifications for this project will be available for examination at The Builders Exchange of the Southern Tier, Inc. - West, 65 East Main St., Falconer, NY 14733 and on their web site. (STBA website at: <https://bxstier.com> Login Page: <http://login.onlineplanservice.com/SP/code.aspx> Password: **NYBX20-00842-029**

Cattaraugus County Local Law 12-2012 as amended by Local Law 5-2015 requires that the County provide a copy of the Cattaraugus County Vendor Responsibility Form to the low bidder. The low bidder will have 5 business days to return the completed form unless the form was mailed by the county to the vendor, in which case they will have 10 business days from the date of the mailing to return the form. Failure by the low bidder to submit the form within the above time frame will lead to the automatic rejection of their bid. The contractor must also ensure that all subcontractors who contract to work on the Project for consideration in the amount of \$35,000 or greater, complete this form and submit it to the County for approval within 5 days of the preconstruction meeting. The contractor must also submit, in writing, a request for waiver for any subcontractors whose contract is for less than \$35,000. Failure to do so may lead to the rejection of the subcontractor at the County's discretion.

Currently the Commissioner of Public Works has approved the CCA-2 (New York State Vendor Responsibility Questionnaire For-Profit Construction) with attachments A, B, and C to serve as the Cattaraugus County Vendor Responsibility Form.

All bids must be sent or delivered to Cattaraugus County Department of Public Works, 8810 Route 242, Little Valley, NY 14755. Attention: Dawn Smith.

All bids must be accompanied by a NON-COLLUSIVE BIDDING CERTIFICATE and Bid Bond in the amount of 5% of bid total. All substitutions are to be submitted at time of bid as per the contract documents. No substitutions will be considered after the bid date. Any bid submitted without such certification and bid bond will not be accepted. Any bid not meeting ALL specifications will not be considered. Cattaraugus County reserves the right to reject any or all bids, to waive any informalities, and to accept the lowest responsible bid.

John Searles
County Administrator
County Center - 303 Court Street
Little Valley, New York 14755

CATTARAUGUS COUNTY DEPARTMENT OF PUBLIC WORKS

DATE: February 28, 2020

Department's Preliminary Estimate for Replacement of:

2020 Bridge Painting Program
CATTARAUGUS COUNTY

Town(s): Freedom, East Otto and South Valley

Description: Cleaning, Priming and Painting of various bridges within Cattaraugus County.

Deposit Required..... 5% of Bid

Department's Estimated Cost of Work..... Confidential

Date of Completion: All work shall be completed by October 31, 2020.

Work to be done: The Contractor shall furnish all materials, equipment, tools and labor of every kind required for existing paint removal; cleaning, priming, and painting of steel; treatment and disposal of waste material; maintenance and protection of traffic; and all other incidental work in the most substantial and workmanlike manner, and do everything required by the Contract Documents as defined herein.

The contract drawings give specific limits and dimensions of work to be completed. A general scope of work is given on page E-8 that denotes work to be done by the Contractor. All items of work are to be included in the unit prices bid listed in section A.

GENERAL NOTE

In general, the New York State Department of Transportation Specifications of January 1, 2020, and all addenda in effect on the date of advertising for bids shall apply, except where modified in these specifications. Where reference is made to New York State, State Department of Transportation, Commissioner, etc., the appropriate Cattaraugus County department or official shall be substituted.

The Commissioner of the Cattaraugus County Department of Public Works shall make the final interpretations of any irregularities, ambiguities or questions arising out of these specifications and the New York State Department of Transportation Specifications used on this project.

The Proposal consisting of Bidding Forms, Required Certifications and Reference Sheet are included in Sections A and B. The submission of the completed forms and a duplicate will constitute a formal Bid. The entire proposal book, including completed forms, shall be submitted for the bid opening. The Agreement (Section C) will be completed upon award of the Contract.

The pages in this proposal and in the plans are numbered consecutively. In the event that any pages are missing or illegible, a replacement copy will be furnished free of charge by the Department of Public Works upon request. The County is responsible for providing amendments only to those persons or firms listed as having purchased plans and/or proposals from the County Department of Public Works and of those that made specific request of the Department for amendments. Persons or firms who obtain plans and/or proposals from sources other than the County Department of Public Works bear the sole responsibility for obtaining any amendments issued by the County for the subject project. Bidders are advised that the County will exercise its right to reject any proposal, pursuant to Section 103-01 of the Standard Specifications, in which subtask bids appear in the Commissioner's judgment to constitute an unbalanced bid for work.

TABLE OF CONTENTS

Section A	Itemized Bid Sheets *	A-1 – 5
Section B	Required Certifications and Federal Aid Contract Requirements	
	1. Itemized Proposal Signature Form *	B-1
	2. Acknowledgement of Receipt of Addenda *	B-2
	3. Bid Bond Form *	B-3 - 4
	4. Bidder Information Sheet *	B-5
	5. Certification for Federal Aid Contracts	B-6
	6. Requirements Regarding Lobbying Activities on Federal Aid Contracts *	B-7 - 10
	7. Non-Collusive Bidding Certifications *	B-11 – 17
	8. Reporting Violations of Non-Collusive Bidding Procedures, Misconduct or Other Prohibited Contract Activities	B-18
	9. Requirements for the Participation of Disadvantaged Business Enterprises in Federal Aid Contracts *	B-19 – 26
	10. Equal Opportunity Requirements for Federal Aid Contracts	B-27 - 28
	11. Required Contract Provisions for Federal Aid Contracts	B-29 - 59
	12. Reference Sheet *	B-60
	13. Local Law Number 05-2015 *	B-61 - 63
	14. Iran Divestment Act of 2012 *	B-64
	15. Affidavit of Compliance and Receipt of Prevailing Wage Rate Schedule *	B-65
Section C	Agreement **	C-1 - 10
Section D	Definitions and Terms	D-1 - 2
Section E	General Provisions	E-1 - 22
Section F	Special Notes	F-1 - 7
Section G	Special Specifications	G-1
Section H	Technical Specifications	H-1

* To be completed by All Bidders and Returned with Bid.

** To be completed after Award.

Section I	Prevailing Wage Rates	
	1. Provisions Relating to NYS Labor Law, Prevailing Wages and the Use of Convict Labor and Materials on Federal and State Contracts.....	I-1 - 3
	2. New York State Department of Labor Prevailing Wage Rates.....	I-4 - 85
	3. Davis-Bacon Act Prevailing Wage Rates.....	I-86 - 110
Section J	Supplemental Information	
	1. Supplemental Information Available to Bidders (CONR 9g).....	J-2
	2. Location Maps, Structure Data Sheet with Photos.....	J-3 - 17
	3. Lead Testing Results.....	J-18 - 20

SECTION A

UNIT PRICE BID SCHEDULE

The Contractor shall furnish all materials, equipment, tools and labor of every kind required to complete the 2020 Bridge Painting Program and perform all other highway work and incidental work in the most substantial and workmanlike manner, and do everything required by the Contract Documents as defined herein.

The total unit price shall be the sum of all materials and installation cost for each bid item as defined herein.

Each Itemized Bid price shall be entered both in words and numerically in the spaces provided under each item. In the event of a discrepancy between the words and numbers as written, the words will be used for tabulation purposes.

DETERMINATION OF LOW BIDDER

Except where the COUNTY exercises the right to reject any or all Proposals, the COUNTY will award the Contract to the lowest responsive and responsible Bidder on the basis of the total bid which shall be the Base Bid and any alternates the COUNTY may select as stated before bid opening based on the available funding, provided further that such Bidder furnishes adequate security therefore and complies with all requirements of the Notice to Bidders and these Instructions to Bidders, after investigations are made to determine the Bidders' responsibility and capability.

For the award the base bid and that alternates are as follows:

- Base Bid: Freedom Bridge No. 1, BIN 3321510,
- Alternate 1: East Otto Bridge No. 27, BIN 3321150
- Alternate 2: South Valley No. 4, BIN 3323210

The bids shall be awarded on the following the criteria:

- If all bids for the Base Bid plus Alternates 1&2 exceed the budget figure, the award will be based on the Base Bid plus Alternate 1; however,
- If all bids for the Base Bid plus Alternate 1 exceed the budget figure, the award will be based on the Base Bid.

**BID FORMS OMITTED FROM
SPECIFICATION BOOKS**

TO OBTAIN BID FORMS PLEASE CONTACT

DAWN SMITH AT 716-938-9121 EXT. 2465

OR SEND EMAIL REQUEST TO:

dasmith@cattco.org

SECTION B

ITEMIZED BID PROPOSAL

In submitting this bid, the undersigned declares that he/she is or they are the only person or persons interested in the bid; that it is made without any connection with any person making another bid for the same contract; that the bid is in all respects fair and without collusion, fraud or mental reservation; and that no official of the County or any person in the employ of the County is directly or indirectly interested in the bid or in the supplies or work to which it relates, or in any portion of the profits thereof.

The undersigned also declares that he/she has or they have carefully examined the plans, specifications and form of contract, and that he has or they have personally inspected the actual location of the work, together with the local sources of supply, has or have satisfied himself or themselves as to all the full scope of the work and existing conditions, and understands that in signing this proposal, he/she or they waive all rights to plead any misunderstandings regarding the same. The Contractor at his own expense may elect to obtain additional information at the site, such as deep holes or borings; however, he/she must inform the County three days prior to such explorations.

The undersigned further understands and agrees that he/she is or they are to furnish and provide for the respective work, all the necessary materials, machinery, implements, tools, labor, services and other items of whatever nature, and to do and perform all work necessary under the aforesaid conditions; to complete the improvement of the aforementioned project in accordance with the plans and the specifications for such improvement, which plans and specifications it is agreed are a part of this proposal.

The undersigned further agrees to accept the aforesaid Itemized Bid as compensation for the completion of the project as detailed in the contract documents.

Dated: _____, 20_____

Legal Name of Person, Firm or Corporation

By: _____
Must be Signed in Ink

ACKNOWLEDGMENT OF RECEIPT OF ADDENDA

The undersigned acknowledges receipt of the following addenda to the subject project (if none, state "NONE"):

Addendum No. _____ Dated _____

Addendum No. _____ Dated _____

Addendum No. _____ Dated _____

Receipt is hereby acknowledged for all addenda listed above.

Signature of Bidder _____ Date _____

BID BOND
Sec. 38 – Highway law

KNOW ALL MEN BY THESE PRESENTS, That
(Name of Contractor)

.....
(Address)

(hereinafter called the "Principal") and the
a corporation created and existing under the laws of the State of, having its
principal office in the City of (hereinafter called the "Surety"), are held and
firmly bound unto Cattaraugus County (hereinafter called the "County") in the full just sum of Five
Percent (5%) of Attached Bid, good and lawful money of the United States of America, for the payment
of which said sum of money, well and truly to be made and done, the said Principal binds themselves
(himself, itself), their (his, its) heirs, executors and administrators, successors and assigns, and the said
Surety binds itself, its successors and assigns jointly and severally, firmly by these presents:

Signed, sealed and dated this 20 A.D.

WHEREAS, the said Principal has submitted to the Cattaraugus County Commissioner of Public
Works, a bid proposal for
(Description of Project)

AND

WHEREAS, under the terms of the Laws of the State of New York as above indicated, the said
Principal has filed or intends to file this bond to guarantee that the Principal will execute all required
contract proposal documents and furnish such faithful performance or other bonds as may be required by
law in accordance with the terms of the Principal's said proposal.

NOW, THEREFORE, the condition of the foregoing obligations is such, that if the said Principal
shall promptly execute and submit, and the Commissioner of Public Works shall accept, all required
contract proposal documents including such faithful performance bond or other bonds as may be required
by law in accordance with the terms of the Principal's said proposal, then this obligation shall be null and
void, otherwise to remain in full force and virtue.

IN TESTIMONY WHEREOF, the said Principal has hereunto set his/her (their, its) hand and seal
and the said Surety has caused this instrument to be signed by
its.....President and itsSecretary, and its
corporate seal to be hereunto affixed, the day and year first above written.

Signed, sealed and delivered in the presence of:

(Corporate seal of (L.S.)
Principal if a (L.S.)
corporation)

..... (L.S.)
Principal
..... Company

(Corporate seal of
Surety Co.)

of

By
(Title of Officer)

Attest.....
(Title of Officer)

(Acknowledgment by principal, unless it is a corporation)
STATE OF NEW YORK

SS:

COUNTY OF

On this day of 20....., before me personally came
....., to me known and known to me to be the person described in and who executed
the foregoing instrument, and acknowledged that he/she executed the same.

.....
Notary Public County

(Acknowledgment by principal, if a corporation)
STATE OF NEW YORK

SS:

COUNTY OF

On this Day of 20....., before me personally came
....., to me known who being by me duly sworn, did depose and say that he/she
resides in; that he/she is the of the
.....; the corporation described in and which executed the foregoing instrument;
that he/she knew the seal of said corporation; that the seal affixed to said instrument was such corporate
seal; that it was so affixed by order of the Board of Directors of said corporation, and that he/she signed
his/her name thereto by like order.

.....
Notary Public County

(Acknowledgment by Surety Company)
STATE OF NEW YORK

SS:

COUNTY OF

On this day of 20....., before me personally came
....., to me known, who being by me duly sworn, did depose and say that he/she
resides in; that he/she is the of the
.....; the corporation described in and which executed the within instrument; that
he/she knows the seal of said corporation; that the seal affixed to said instrument is such corporate seal;
that it was so affixed by the order of the Board of Directors of said corporation, and that he/she signed
his/her name there to by like order.

.....
Notary Public County

BIDDER INFORMATION SHEET

NAME OF BIDDER: * _____

ADDRESS: _____

PHONE NUMBER: _____

TYPE OF ENTITY: CORPORATION _____ PARTNERSHIP _____ INDIVIDUAL _____

IF A NON-PUBLICLY OWNED CORPORATION:

NAME OF CORPORATION: _____

LIST OF PRINCIPAL STOCKHOLDERS (HOLDING OVER 5% OF OUTSTANDING SHARES):

LIST OF OFFICERS: _____

LIST OF DIRECTORS: _____

DATE OF ORGANIZATION: _____

IF A PARTNERSHIP:

PARTNERS: _____

NAME OF PARTNERSHIP: _____

DATE OF ORGANIZATION: _____

* IF THE BUSINESS IS CONDUCTED UNDER AN ASSUMED NAME, A COPY OF THE CERTIFICATE REQUIRED TO BE FILED UNDER THE NEW YORK GENERAL BUSINESS LAW MUST BE ATTACHED.

CERTIFICATION FOR FEDERAL AID CONTRACTS

The prospective participant certifies, by signing and submitting this bid or proposal, to the best of his/her knowledge and belief, that:

1. No Federal appropriated funds have been paid or will be paid, by or on behalf of the undersigned, to any person for influencing or attempting to influence an officer or employee of any Federal agency, a Member of Congress, an officer or employee of Congress, or an employee of a Member of Congress, in connection with the awarding of any Federal contract, the making of any Federal grant, the making of any Federal loan, the entering into of any cooperative agreement, and the extension, continuation, renewal, amendment, or modification of any Federal contract, grant, loan, or cooperative agreement.
2. If any funds other than Federal appropriated funds have been paid or will be paid to any person for influencing or attempting to influence an officer or employee of any Federal agency, a Member of Congress, an officer or employee of Congress, or an employee of a Member of Congress, in connection with this Federal contract, grant, loan, or cooperative agreement, the undersigned shall complete and submit Standard Form-LLL, "Disclosure Form to Report Lobbying", in accordance with its instructions.

This certification is a material representation of fact upon which reliance was placed when this transaction was made or entered into. Submission of this certification is a prerequisite for making or entering into this transaction imposed by Section 1352, Title 31, U. S. Code. Any person who fails to file the required certification shall be subject to a civil penalty of not less than \$10,000.00 and not more than \$100,000.00 for each such failure.

The prospective participant also agrees by submitting his/her bid or proposal that he/she shall require that the language of this certification be included in all lower tier subcontracts which exceed \$100,000.00 and that such sub-recipients shall certify and disclose accordingly.

INSTRUCTIONS FOR COMPLETION OF SF-LLL, DISCLOSURE OF LOBBYING ACTIVITIES

This disclosure form shall be completed by the reporting entity, whether sub-awardee or prime Federal recipient, at the initiation or receipt of a covered Federal action, or a material change to a previous filing, pursuant to title 31 U.S.C. section 1352. The filing of a form is required for each payment or agreement to make payment to any lobbying entity for influencing or attempting to influence an officer or employee of any agency, Member of Congress, an officer or employee of Congress, or an employee of a Member of Congress in connection with a covered Federal action. Complete all items that apply for both the initial filing and material change report. Refer to the implementing guidance published by the Office of Management and Budget for additional information.

1. Identify the type of covered Federal action for which lobbying activity is and/or has been secured to influence the outcome of a covered Federal action.
2. Identify the status of the covered Federal action.
3. Identify the appropriate classification of this report. If this is a follow-up report caused by a material change to the information previously reported, enter the year and quarter in which the change occurred. Enter the date of the last previously submitted report by this reporting entity for this covered Federal action.
4. Enter the full name, address, city, state and zip code of the reporting entity. Include Congressional District, if known. Check the appropriate classification of the reporting entity that designates if it is, or expects to be, a prime or sub-award recipient. Identify the tier of the sub-awardee, e.g., the first sub-awardee of the prime is the 1st tier. Sub-awards include but are not limited to subcontracts, sub-grants, and contract awards under grants.
5. If the organization filing the report in item 4 checks "Sub-awardee", then enter the full name, address, city, state and zip code of the prime Federal recipient. Include Congressional District, if known.
6. Enter the name of the Federal agency making the award or loan commitment. Include at least one organizational level below agency name, if known. For example, Department of Transportation, United States Coast Guard.
7. Enter the Federal program name or description for the covered Federal action (item 1). If known, enter the full Catalog of Federal Domestic Assistance (CFDA) number for grants, cooperative agreements, loans, and loan commitments.
8. Enter the most appropriate Federal identifying number available for the Federal action identified in item 1 (e.g., Request for Proposal (RFP) number; Invitation for Bid (IFB) number; grant announcement number; the contract, grant, or loan award number; the application/proposal control number assigned by the Federal agency). Include prefixes, e.g., "RFP-DE-90-001".

9. For a covered Federal action where there has been an award or loan commitment by the Federal agency, enter the Federal amount of the award/loan commitment for the prime entity identified in item 4 or 5.
10. (a) Enter the full name, address, city, state and zip code for the lobbying registrant under the Lobbying Disclosure Act of 1995 engaged by the reporting entity identified in item 4 to influence the Federal covered action.
11. (b) Enter the full names of the individual(s) performing services, and include full address if different from 10(a). Enter Last Name, First Name, and Middle Initial (MI).
12. The certifying official shall sign and date the form; print his/her name, title, and telephone number.

According to the Paperwork Reduction Act, as amended, no persons are required to respond to a collection of information unless it displays a valid OMB Control Number. The valid OMB Control Number for this information collection is OMB No. 0348-0046. Public reporting burden for this collection of information is estimated to average 10 minutes per response, including time for reviewing instructions, searching existing data sources, gathering and maintaining the data needed, and completing and reviewing the collection of information. Send comments regarding the burden estimate or any other aspect of this collection of information, including suggestions for reducing this burden, to the Office of Management and Budget, Paperwork Reduction Project (0348-0046), Washington D.C. 20503.

DISCLOSURE OF LOBBYING ACTIVITIES

Complete this form to disclose lobbying activities pursuant to 31 U.S.C. 1352 (See reverse for public burden disclosure.)

1. Type of Federal Action:	2. Status of Federal Action:	3. Report Type:
a. contract	a. bid/offer/application	a. initial filing
b. grant	b. initial award	b. material change
c. cooperative agreement	c. post-award	For Material Change Only:
d. loan		year _____ quarter _____
e. loan guarantee		date of last report _____
f. loan insurance		
4. Name and Address of Reporting Entity: <input type="checkbox"/> Prime <input type="checkbox"/> Subawardee Tier _____, if known:		5. If Reporting Entity in No. 4 is a Subawardee, Enter Name and Address of Prime:
Congressional District, if known:		Congressional District, if known:
6. Federal Department/Agency:	7. Federal Program Name/Description:	
	CFDA Number, if applicable:	
8. Federal Action Number, if known:	9. Award Amount, if known:	
	\$ _____	
10. a. Name and Address of Lobbying Registrant (if individual, last name, first name, MI):	b. Individuals Performing Services (including address if different from No. 10a) (last name, first name, MI):	
11. Information requested through this form is authorized by title 31 U.S.C. section 1352. This disclosure of lobbying activities is a material representation of fact upon which reliance was placed by the tier above when this transaction was made or entered into. This disclosure is required pursuant to 31 U.S.C. 1352. This information will be available for public inspection. Any person who fails to file the required disclosure shall be subject to a civil penalty of not less than \$10,000 and not more than \$100,000 for each such failure.	Signature: _____	
	Print Name: _____	
	Title: _____	
	Telephone No.:	Date:
Federal Use Only:	Authorized for Local Reproduction Standard Form LLL (Rev. 7-97)	

REQUIREMENTS REGARDING LOBBYING ACTIVITIES ON FEDERAL AID CONTRACTS

DISCLOSURE OF LOBBYING ACTIVITIES

Approved by
OMB
0348-0046

Continuation Sheet

Reporting Entity: _____ Page _____ Of _____

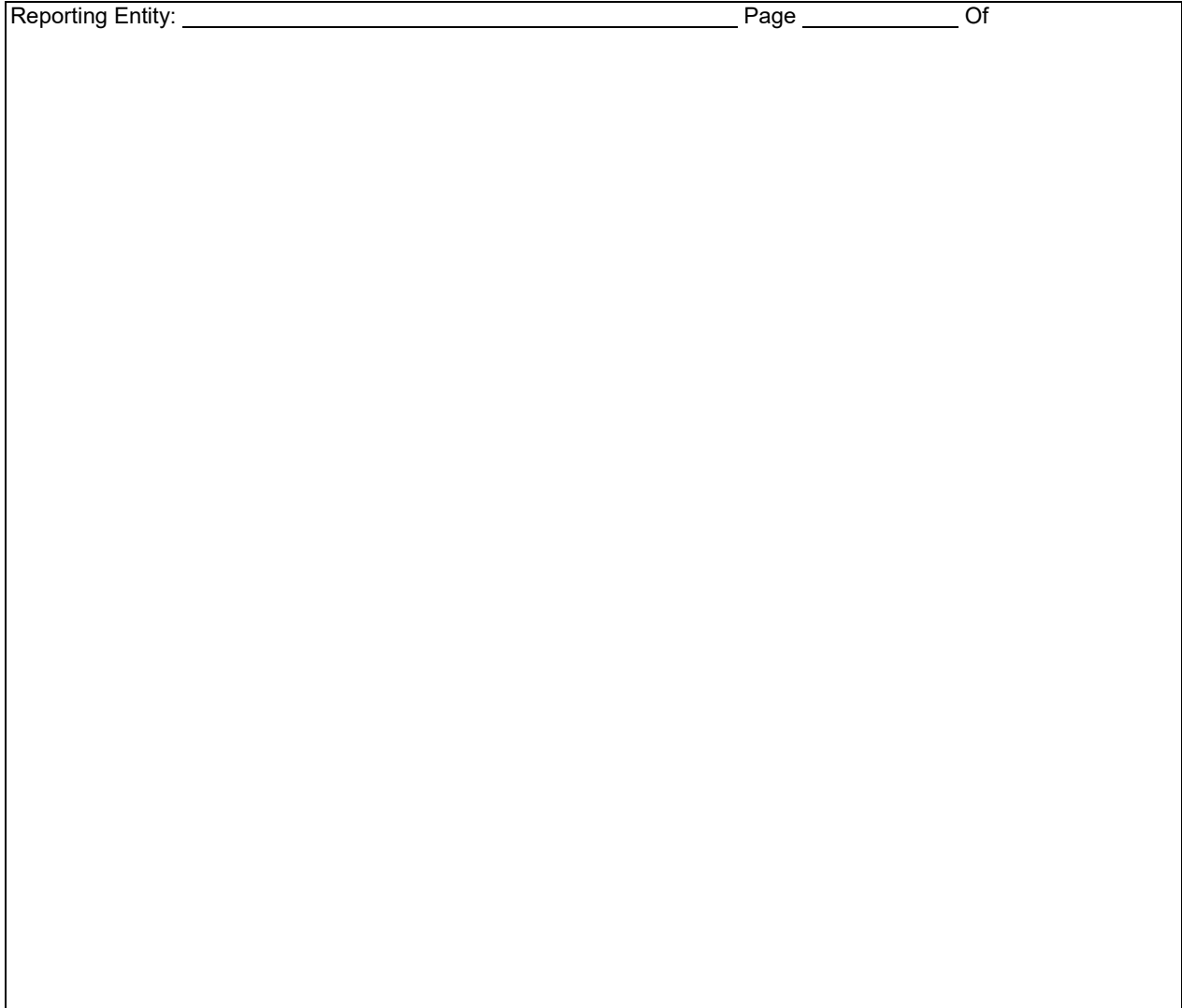

Authorized for Local Reproduction - Standard Form LLL

NON-COLLUSIVE BIDDING CERTIFICATIONS

REQUIRED BY SECTION 139-D, STATE FINANCE LAW and SECTION 103-D OF GENERAL MUNICIPAL LAW

“Section 139-d, SFL and Section 103-d, GML, “Statement of non-collusion in bids to the state.”

1. Every bid hereafter made to the state or any public department, agency, or official thereof, where competitive bidding is required by statute, rule, or regulation, for work or services performed or to be performed or goods sold or to be sold, shall contain the following statement subscribed by the bidder and affirmed by such bidder as true under the penalties of perjury:

Non-collusive bidding certification.

(a) By submission of this bid, each bidder and each person signing on behalf of any bidder certifies, and in the case of a joint bid, each party thereto certifies as to its own organization, under penalty of perjury, that to the best of his knowledge and belief:

(1) The prices in this bid have been arrived at independently without collusion, consultation, communication, or agreement, for the purpose of restricting competition, as to any matter relating to such prices with any other bidder or with any competitor;

(2) Unless otherwise required by law, the prices which have been quoted in this bid have not been knowingly disclosed by the bidder and will not knowingly be disclosed by the bidder prior to opening, directly or indirectly, to any other bidder or to any competitor; and

(3) No attempt has been made or will be made by the bidder to induce any other person, partnership, or corporation to submit or not to submit a bid for the purpose of restricting competition.

(b) A bid shall not be considered for award nor shall any award be made where (a)(1)(2) and (3) above have not been complied with; provided however, that if in any case the bidder cannot make the foregoing certification, the bidder shall so state and shall furnish with the bid a signed statement which sets forth in detail the reasons therefore. Where (a)(1)(2) and (3) above have not been complied with, the bid shall not be considered for award nor shall any award be made unless the head of the purchasing unit of the state, public department, or agency to which the bid is made, or his designee, determines that such disclosure was not made for the purpose of restricting competition.

The fact that the bidder (a) has published price lists, rates, or tariffs covering items being procured, (b) has informed prospective customers of proposed or pending publication of new or revised price lists for such items or (c) has sold the same items to other customers at the same prices being bid, does not constitute, without more, a disclosure within the meaning of subparagraph one (a).

2. Any bid hereafter made to the state or any public department, agency, or official thereof by a corporate bidder for work or services performed or to be performed or goods sold or to be sold, where competitive bidding is required by statute, rule, or regulation, and where such bid contains the certification referred to in subdivision one of this section, shall be deemed to have been authorized by the board of directors of the bidder and such authorization shall be deemed to have included the signing and submission of the bid and the inclusion therein of the certificate as to non-collusion as the act and deed of the corporation."

REQUIRED BY TITLE 23, U. S. CODE, AND SECTION 112. A NON-COLLUSIVE BIDDING CERTIFICATION MUST BE INCLUDED IN EVERY BID PROPOSAL REGARDLESS OF WHETHER NYSDOT SPECIFICATIONS OR LOCAL SPECIFICATIONS ARE USED.

(A)2

"By submission of this bid, the bidder does hereby tender to the Owner this sworn statement pursuant to Section 112(c) of Title 23, U. S. Code-Highways and does hereby certify, in conformance with said Section 112 of Title 23, U. S. Code-Highways that the said Contractor has not, either directly or indirectly, entered into any agreement, participated in any collusion, or otherwise taken any action in restraint of free competitive bidding in connection with the above contract."

REQUIRED BY TITLE 49, CFR, VOLUME 1, SUBTITLE A, PART 29

"The signator to the proposal, being duly sworn, certifies that, EXCEPT AS NOTED BELOW, his/her company and any person associated therewith in the capacity of owner, partner, director, officer, or major stockholder (of five percent or more ownership):

1. Is not currently under suspension, debarment, voluntary exclusion, or determination of ineligibility by any Federal agency;
2. Has not been suspended, debarred, voluntarily excluded, or determined ineligible by any Federal agency within the past three years;
3. Does not have a proposed debarment pending; and
4. Has not been indicted, convicted, or had a civil judgment rendered against it by a court of competent jurisdiction in any matter involving fraud or official misconduct within the past three years.

EXCEPTIONS: The Contractor should list any relevant information, attaching additional sheets to the proposal if necessary. (Exceptions will not necessarily result in disapproval, but will be considered in determining responsibility. For any exception noted, the Contractor should indicate to whom it applies, the initiating agency, and the dates of actions. Providing false information may result in criminal prosecution or administrative sanctions).

THE FOLLOWING PAGES ARE THE REQUIRED CERTIFICATION REGARDING NON-COLLUSIVE BIDDING PROCEDURES AND THE CONTRACTOR'S ELIGIBILITY TO SUBMIT A BID UNDER FEDERAL LAW. THE LAST PAGE IS A GENERAL BIDDER INFORMATION FORM. ALL SHOULD BE INCLUDED IN THE CONTRACT DOCUMENTS, IMMEDIATELY FOLLOWING THE PAGE(S) WHICH CONTAINS THE NON-COLLUSIVE BIDDING REQUIREMENTS. BY SIGNING ONE OF THESE CERTIFICATIONS, THE CONTRACTOR CERTIFIES THAT HE UNDERSTANDS AND AGREES TO BE BOUND BY THE PROVISIONS OF THE FOLLOWING LAWS:

- 1. NEW YORK STATE FINANCE LAW, ARTICLE 9, SECTION 139-d**
- 2. TITLE 49, CFR, PART 29**
- 3. TITLE 23, U. S. CODE-HIGHWAYS, SECTION 112**

THE CONTRACTOR SHOULD CHOOSE THE APPROPRIATE NOTARIZATION WHICH CORRESPONDS TO THE TYPE OF COMPANY (SOLE PROPRIETORSHIP, PARTNERSHIP, OR CORPORATION) THAT HE/SHE REPRESENTS OR IS AFFILIATED WITH. ALL BIDDERS SHOULD FILL OUT THE APPROPRIATE SECTION OF THE BIDDER INFORMATION SHEET.

BY EXECUTING THIS DOCUMENT, THE CONTRACTOR AGREES TO:

1. Perform all work listed in accordance with the Contract Documents at the unit prices bid; subject to the provisions of Section 104 -04, Standard Specifications, Construction and Materials, published by the New York State Department of Transportation, and dated May 1, 2019, if applicable;
2. All the terms and conditions of the non-collusive bidding certifications required by Section 103-d of the General Municipal, and Section 112(c), Title 23, U.S. Code;
3. Certification of Specialty Items category selected, if contained in this proposal;
4. Certification of any other clauses required by this proposal and contained herein;
5. Certification, under penalty of perjury, as to the current history regarding suspensions, debarments, voluntary exclusions, determinations of ineligibility, indictments, convictions, or civil judgments required by 49 CFR Part 29.

Date: _____
(Legal Name of Person, Corporation, or Firm Which
is Submitting Bid or Proposal)

BY: _____
(Signature of Person Representing Above)

AS: _____
(Official Title of Signatory in Above Firm)

(Acknowledgment by Individual Contractor, If a Corporation)

STATE OF NEW YORK)
COUNTY OF CATTARAUGUS) SS:

On this _____ day of _____, 20____, before me personally
came _____, to me known and known to me to be the person
who
executed the above instrument, who being duly sworn by me, did depose and say that he/she resides at
_____, and that he/she is the _____ of
the
corporation described in and which executed the above instrument, and that he/she signed his/her name
thereto on behalf of said Corporation by order of the Board of Directors of said Corporation.

Notary Public

(Acknowledgment by Co-Partnership Contractor)

STATE OF NEW YORK)
COUNTY OF CATTARAUGUS) SS:

On this _____ day of _____, 20___, before me personally
came _____, to me known and known to me to be the person
described in and who executed the above instrument, who, being duly sworn by me, did for
himself/herself

depose and say that he/she is a member of the firm of _____,
consisting of himself/herself and _____, and that he/she
executed the foregoing instrument in the firm name of _____,
and

that he/she had authority to sign same, and did duly acknowledge to me that he/she executed same as
the act

and deed of said firm of _____, for the uses and purposes mentioned
herein.

_____, and that he/she is the _____ of
the

corporation described in and which executed the above instrument, and that he/she signed his/her name
thereto on behalf of said Corporation by order of the Board of Directors of said Corporation.

Notary Public

(Acknowledgment by Individual Contractor)

STATE OF NEW YORK)
COUNTY OF CATTARAUGUS) SS:

On this _____ day of _____, 20___, before me personally
came _____, to me known and known to me to be described
in and

who executed the foregoing instrument, and that he/she acknowledged that he/she executed the same.

Notary Public

NON-COLLUSIVE BIDDING CERTIFICATION BIDDER INFORMATION

Bidder to provide information listed below:

Bidder Address: _____
Street or P. O. Box No.

City

State ZIP

Federal Identification No.: _____

Name of Contact Person: _____

Phone # of Contact Person: _____

If Bidder is a Corporation:

President's Name & Address:

Secretary's Name & Address:

Treasurer's Name & Address:

If Bidder is a Partnership:

Partner's Name & Address:

Partner's Name & Address:

If Bidder is a Sole Proprietorship:

Owner's Name & Address:

**REPORTING VIOLATIONS OF NON-COLLUSIVE BIDDING PROCEDURES,
MISCONDUCT, OR OTHER PROHIBITED CONTRACT ACTIVITIES**

U. S. DEPARTMENT OF TRANSPORTATION HOTLINE. Persons with knowledge of bid collusion (i.e., contractors, suppliers, workers, etc.) or other questionable contract related practices (inadequate materials, poor workmanship, theft of materials, etc.) are encouraged to report such activities by calling the U.S.D.O.T. HOTLINE. The HOTLINE number is 1-800-424-9071 and calls will be answered from 8:00 A.M. to 5:00 P.M. EST, Monday thru Friday. This HOTLINE is under the direction of the U.S.D.O.T.'s Inspector General. All information will be treated confidentially and the caller's anonymity will be respected.

NEW YORK STATE INSPECTOR GENERAL HOTLINE. Reports of New York State Governmental Misconduct may be made in strict confidence to the New York State Inspector General on the Toll Free Statewide HOTLINE or by writing to the Office of the Inspector General. The Toll Free Statewide HOTLINE telephone number is 1-800-367-4448 and calls will be answered between 8:00 A.M. and 4:30 P.M., Monday through Friday. The address of the Office of the State Inspector General is the State Capitol, Executive Chamber, Albany, New York 12224.

REQUIREMENTS FOR THE PARTICIPATING OF DISADVANTAGED BUSINESS ENTERPRISES IN FEDERAL AID CONTRACTS

DISADVANTAGED BUSINESS ENTERPRISE UTILIZATION. It is the policy of the United States and the State of New York that Disadvantaged Business Enterprises (DBE's) shall have the maximum opportunity to participate in the performance of State contracts for construction. The parties to this contract shall take all necessary and reasonable steps in accordance with the laws, rules, and regulations cited in this section to ensure that DBEs have the maximum opportunity to compete for and perform contracts. The Owner and its Contractors shall not discriminate on the basis of race, color, national origin, or sex in the award and performance of any federal Aid contracts. This policy shall be made a part of all subcontracts and agreements entered into as a result of this contract.

The Congress of the United States, to this end, has enacted the Surface Transportation Assistance Act ("STAA") of 1982, Public Law 97-424, Section 105(f), the Surface Transportation and Uniform Relocation Assistance Act of 1987, Public Law 100-17, Section 106(c), the Intermodal Surface Transportation Efficiency Act of 1991 and Regulations have been promulgated under CFR 49 23. New York State, to this end, has enacted Section 85 of the Highway Law, Section 428 of the Transportation Law, and Chapter 1, Title 17 of the Official Compilation of Codes, Rules, and Regulations. The parties to this contract are required to comply with these laws, rules, and regulations and the following DBE Program requirements.

- A. **ELIGIBILITY OF DBEs.** Only those DBE firms that are certified by the New York State Department of Transportation (NYSDOT) are eligible to be used for goal attainment on this contract. DBE certification is not an endorsement of the quality or performance of the business but simply an acknowledgement of the firm's status as a DBE. In the event that the apparent Low Bidder, in good faith, proposes to use a firm that is listed as a certified DBE in the project proposal, and that firm is later found by the Owner to be ineligible or unable to perform, then the apparent Low Bidder will be required to substitute another certified firm on the kind needed to meet the goal, before the award, at no additional cost to the Owner.
- B. **GOAL.** The Owner has established a utilization goal for DBEs which is expressed as a percentage of the total contract price. This goal is stated in the proposal and remains in effect throughout the life of the contract. In executing the contract or bid documents the Bidder declares that he/she subscribes to the utilization goal and must meet or exceed the goal or demonstrate that he/she could not meet it despite his/her best efforts. The contract goal is then considered to be a target or a minimum figure to which the Contractor commits as a part of his/her bidding for a Federal-aid project. When the contract is awarded with DBE participation that is less than the contract goal, the Prime Contractor is required to continue good faith efforts, as defined in Section F, throughout the life of the contract in order to increase the DBE participation to meet or exceed the contract goal.
- C. **ZERO PERCENT GOAL.** For contracts which have a 0% (zero percent) goal, the Bidder agrees to make good faith efforts to utilize certified DBEs for any subcontracts awarded by the Bidder in connection with the contract.
- D. **COUNTING DBE PARTICIPATION TOWARDS DBE GOALS.** DBE participation shall be counted toward meeting the DBE goal in accordance with the following:
 - 1. **Subcontracting.** If a firm is determined to be an eligible DBE, as defined in Section A,

the total DBE agreed amount of the items of work to be performed by the DBE is counted toward the applicable DBE goal except as provided in paragraphs 2, 3, and 4 below.

2. Joint Ventures. Joint ventures between certified DBE firms and non-DBE firms as subcontractors will be counted toward the DBE goal in proportion to the percentage of ownership and control of each firm within the joint venture, subject to approval by the Owner of the joint venture agreement to be furnished by the Bidder before award of the contract. The joint venture agreement must include a detailed breakdown of the following:
 - a. Contract responsibility of the DBE for specific contract items of work,
 - b. Capital participation of the DBE,
 - c. Specific equipment to be provided to the joint venture by the DBE,
 - d. Specific responsibilities of the DBE in the control of the joint venture,
 - e. Specific staffing and skills to be provided to the joint venture by the DBE, and
 - f. Percentage distribution to the DBE of the projected profit or loss incurred by the joint venture.

In addition to these requirements, the DBE joint venture must perform a commercially useful function as a DBE subcontractor as defined in Section E.

3. Supplies (Regular Dealers), Manufacturers, and Fabricators. Count toward the DBE goal the expenditures for materials and supplies obtained from DBE suppliers (regular dealers) and manufacturers in the amount noted below. The DBE supplier or manufacturer must assume the actual and contractual responsibility for the provision of the materials and supplies.
 - a. Count the entire expenditure to a DBE manufacturer. A manufacturer is a firm that operates or maintains a factory or establishment that produces on the premises the materials or supplies obtained by the Contractor.
 - b. Count the entire expenditure to a DBE fabricator. A fabricator is a firm that substantially alters materials or supplies before resale.
 - c. Count 60% (sixty percent) of the expenditures to a DBE supplier. A supplier is a firm that owns, operates, or maintains a store, warehouse, or other establishment in which the materials or supplies required for the performance of the contract are bought, kept in stock, and regularly sold to the public in the usual course of business. It is a firm that engages in, as its principal business, and in its own name, the purchase and sale of the products in question. One who deals in bulk items such as steel, cement, gravel, stone, and petroleum products need not keep such product in stock, if it owns or operates distribution equipment.
 - d. The Bidder must indicate in the form of an explanation on the AAPHC-890, DBE Utilization Worksheet, the item number(s) for the material supplied.

EXAMPLE:

ITEM NUMBER	NAME	LESS THAN 100%	AMOUNT
619M17	Supply Temp. Concrete Barrier	XX%	\$ Value

4. Trucking Services. Count toward the DBE goal the expenditure for trucking services provided by certified DBEs in accordance with the following:
 - a. Count the pro-rated value of trucking services provided by trucks owned or leased on a long-term basis by the DBE trucking firm. For the purposes of this Section, a long-term lease is a lease of six (6) months or more. Also, trucks that are leased on a long-term basis are leased without an operator.
 - b. Count the pro-rated value of trucking services provided by trucks hired or rented from other certified DBE trucking firms by the DBE trucking firm.
 - c. No credit will be received for the value of trucking services that are provided by trucks that are not owned, leased on a long-term basis, hired, or rented from certified DBE trucking firms.

EXAMPLE:

Ten (10) trucks are needed to perform \$50,000 of trucking services. The DBE who appears on the Utilization form will provide two (2) self-owned trucks and three (3) trucks hired from DBE trucking firms for a total of five (5) certified DBE trucks providing trucking services. The remaining five (5) trucks are not obtained from certified DBE trucking firms. In this situation, 50% (fifty percent), or \$25,000, can be counted toward the DBE goal.

- d. The Bidder must indicate in the form of an explanation the item number(s) for which the trucking services are to be performed, the type of trucking service to be performed (on-site vs. off-site), and the corresponding dollar value for those services (per item).

EXAMPLE:

ITEM NO.	NAME	LESS THAN 100%	AMOUNT
99.99	Off-site Trucking Services for Item 403.11	XX%	\$ Value

- e. The Bidder must provide, before award, the calculations and any pertinent documentation that support the dollar value or the proposed DBE trucking services. The Bidder must also provide before award a list of all proposed DBE trucking firms to be used on the project and the number of trucks to be provided by each proposed DBE trucking firm.
- f. On-Site Trucking. For the purposes of this Section, on-site trucking is defined as:
 1. Within the boundaries of the physical place where the construction will remain;
 2. Off-site facilities that are dedicated exclusively to the performance of the contract and are so located in proximity to the actual construction location that it would seem reasonable to include them. Trucking services provided for on-site trucking are considered to be a subcontracting activity. The DBE trucking firm may not subcontract any portion of their on-site trucking operations.
- g. Off-Site Trucking. For the purposes of this Section, off-site trucking is defined as:
 1. Outside of the boundaries of the physical place where the construction will remain;
 2. Off-site facilities that were established by a commercial supplier or materialman prior to award of the project and used for multiple customers.

Trucking services provided for off-site trucking are not considered to be a subcontracting activity; it is considered to be a service.

- h. The DBE trucking firm that appears on the Utilization form must control the day-to-day trucking operations on the project.
 - 1. Negotiating and executing rental/leasing agreements;
 - 2. Hiring and firing the work force;
 - 3. Coordinating the daily trucking needs with the Prime Contractor;
 - 4. Scheduling and dispatching trucks.
 - 5. The Bidder must explain in writing the scope of work to be performed by the DBE for all items indicated as partial items at the time the Low Bidder submits the Utilization Package.
 - 6. A DBE that holds a contract may not count its own utilization in the contract toward the DBE contract goal.

E. **CONDITIONS OF PARTICIPATION.** DBE participation will be counted toward meeting the DBE contract goal, subject to all of the following conditions:

- 1. **Commercially Useful Function.** The Prime Contractor is responsible for ensuring that DBEs performing work on the contract perform a commercially useful function. A DBE is considered to perform a commercially useful function when it is responsible for the execution of a distinct element of work on a contract and carries out his/her responsibilities by actually performing, managing, and supervising the work involved in accordance with normal industry practice (except where such practices are inconsistent with the DBE regulations). Regardless of whether an arrangement between the Contractor and the DBE represents standard industry practice, if the arrangement erodes the ownership, control, or independence of the DBE or in any way does not meet the commercially useful function requirement, the Contractor shall receive no credit toward the goal.
- 2. **Work Force.** The DBE firm must employ a work force (including administrative and clerical positions), separate and apart from that employed by the Prime Contractor, other subcontractors on the project, or their affiliates. This does not preclude the employment by the DBE of an individual that has been previously employed by another firm involved in the contract, provided that the individual was independently recruited by the DBE in accordance with customary industry practice. The routine transfer of work crews from another employer to the DBE shall not be allowed.
- 3. **Supervision.** All work performed by the DBE must be controlled and supervised by the DBE without duplication of supervisory personnel from the Prime Contractor or other subcontractors. This does not preclude routine communication between the supervisory personnel of the DBE and other supervisors necessary to coordinate the work of the contract.
- 4. **Equipment.** DBE subcontractors may supplement their equipment by renting or leasing additional equipment in accordance with customary industry practice. However, no more than 50% of the equipment required to perform the work of the subcontractor may be obtained from the Prime Contractor, other subcontractors on the project, or their affiliates. If the DBE obtains equipment from any of those sources, the Owner shall obtain from the DBE documentation demonstrating that similar equipment and terms could not be obtained at a lower cost from other

customary sources of equipment. The required documentation shall include, but not be limited to, copies of the rental or leasing agreements, and the names, addresses, and terms quoted by other sources of equipment

F. GOOD FAITH EFFORTS. To ensure that DBE firms are given the maximum practical opportunity to participate in the work of the contract, the Bidder must make good faith efforts to obtain DBE participation in order to fulfill the DBE contract goal. The Bidder's demonstration of good faith efforts must be at least extensive as, but not limited to, the following:

1. Efforts to utilize the services of minority and women community organizations; minority and women contractors groups; local, State, and Federal minority and women business assistance offices; and other organizations that provide assistance in the recruitment and placement of DBEs.
2. Attendance by a representative of the Bidder who is knowledgeable of the contract work at pre-bid, pre-award, and/or other meetings, if any, scheduled by the Owner to inform DBEs of subcontracting and other opportunities for participation in a specific contract. At these meetings, the Bidder's representative will explain the required contract work and solicit the interest of the DBE attendees in any specific portions of the work.
3. Efforts to secure participation by certified DBE firms. Only DBEs certified by the NYSDOT shall be used to fulfill goals on federally funded projects.
4. Written solicitation of DBEs. A written solicitation inquiry will be sent to all DBE firms and, when necessary, minority and women's business associations when necessary in order to meet DBE goals. Notification must be made in a timely fashion such that the DBEs contacted have a reasonable period of time in which to respond. The Bidder's solicitation will cover certified DBEs listed in the Registry of Disadvantaged Business Enterprises maintained by the Office of Civil Rights (OCR) of the NYSDOT. Such geographic limits are not acceptable as good faith efforts for work typically subcontracted to non-DBE firms on a statewide basis, e. g., pavement markings, guide rail, etc. It will be mandatory for the Bidder to contact all DBEs who have expressed interest in the specific contract to the Bidder and to document efforts taken to secure their participation in the contract and in any future work.
5. Efforts to select portions of the work proposed to be performed by DBEs in order to increase the likelihood of achieving the contract goal. Where certified DBEs have expressed interest to the Bidder in performing certain work that the Bidder normally performs with his/her own forces, and the contract goal has not otherwise been attained, the Bidder will be required to subcontract such work or portions of it in order to meet the goal.
6. Efforts to negotiate with DBEs for specific subcontracts. Price alone will not be an acceptable basis for rejecting DBE bids, unless it can be shown that no reasonable price can be obtained from a DBE.
7. Efforts to assist the DBEs contacted which needed assistance in obtaining bonding or insurance required by the Bidder or the Owner. Difficulties encountered by the DBE in obtaining bonding or insurance required by the Bidder will not be acceptable reasons for the Bidder's failure to meet the contract goal.

8. Providing interested DBEs with adequate information about the plans, specifications, and requirements of the contract.
 9. Record of solicitation efforts. All Bidders must keep records of efforts to solicit and negotiate with DBEs and a continuing record of pre- and post-letting activity. When submitting a D/M/WBE Schedule of Utilization to the Owner, the apparent Low Bidder will attach it together with the supplemental information specified in the instructions as evidence of good faith efforts. Such supplemental efforts must include at least the following:
 - a. All Solicitation Responses returned to the Bidder by DBEs
 - b. All envelopes of solicitation inquiries that were returned as undeliverable; and
 - c. Any quotations submitted by DBEs that are not included in the D/M/WBE Schedule of Utilization with an explanation for the Bidder's action in each case.
- G. **DBE UTILIZATION PACKAGE.** The Bidder shall submit a complete utilization package within seven (7) calendar days after the bid opening. The DBE Utilization Package consists of:
1. D/M/WBE Schedule of Utilization;
 2. D/M/WBE Utilization Worksheet (Note: Schedule must be co-signed by both the Prime Contractor and the Subcontractor); and
 3. All of the information listed in Section F.
- H. **BIDDER'S FAILURE TO COMPLY.** The Owner's acceptance of the Bidder's proposal is conditioned upon the Bidder's fulfillment of the requirements of this Section. If the Bidder fails to submit a complete utilization package as defined in Section G by the seventh calendar day after the bid opening and/or fails to attain the DBE utilization goal, and to satisfactorily document his/her good faith efforts as defined in Section F above, the bid may be declared incomplete and the deposit may be subject to forfeiture.
- I. **DISADVANTAGED BUSINESS ENTERPRISE OFFICER.** The Bidder shall designate a Disadvantaged Business Enterprise Officer who will have the responsibility to, and be capable of, effectively administering and promoting an active DBE program, and, who is assigned adequate authority to do so.
- J. **CONFORMANCE TO DBE SCHEDULE OF UTILIZATION.** Following the award of the contract, the Contractor is required to enter into subcontracts or agreements with the DBEs identified on the approved D/M/WBE Schedule of Utilization, for the work of the kind and amount identified therein. The Owner will monitor the work of the contract to ensure that the DBEs identified perform the work in accordance with the D/M/WBE Schedule of Utilization. Any direction by the Owner to comply with the Schedule is a lawful direction under Article 8 of the contract. Where such direction is not complied with, the Contractor shall not be entitled to have any estimate made for the purpose of payment, nor shall any estimate be rendered on account of work done or material furnished.
- K. **REVISIONS IN DBE UTILIZATION.** If, after the award of the contract, a subcontract or purchase order held by a DBE or joint venture involving a DBE is modified or terminated,

the Contractor shall immediately notify the Owner of such modification or termination and the reasons therefore or an alternative subcontract or purchase order for a commensurate dollar amount furnished by another DBE. Any change in DBE utilization must be approved by the Owner through submission of a revised Schedule of Utilization (Amended) signed by both parties. The Contractor must receive this approval prior to implementing any proposed change. Failure by the Contractor to obtain approval could result in appropriate sanctions. For the purposes of this Section, a revision in DBE utilization is considered to be any of the following modifications:

1. Reducing the dollar value of or eliminating the DBE's item(s) of work. In the event that this results in a shortfall in goal attainment, the Contractor will be required to make good faith efforts to backfill in accordance with Section F.
2. Removing one DBE and substituting another DBE for the same item(s) of work.
3. Increasing the dollar value of (an) item(s) of work or adding (a) new item(s) of work to a DBE already participating in the contract.
4. Adding a DBE to the contract.

- L. **MONITORING CONTRACTOR COMPLIANCE.** The Contractor will allow authorized representatives of the Owner to conduct periodic inspections of the Contractor's DBE participation efforts during the performance of the contract. In order to determine whether the Contractor has complied with the requirements of this Section, the Owner may proceed by order to show cause, or may follow any other lawful procedure upon due notice in writing to the Contractor. When the Contractor has been found to have failed to meet the contract goals, to exert a good faith effort, or otherwise failed to comply with this Section, the contract may be canceled, terminated, or suspended in whole or in part in accordance with the contract and Section 40 of the Highway Law, and the Contractor may be referred to the USDOT for possible suspension or debarment as provided for in 49 CFR 29 and such other sanctions as may be imposed and remedies invoked as provided for under the authority of 49 CFR 29, or by rule, regulation, or order of the Owner, or as otherwise provided by law.
- M. **PROMPT PAYMENT.** Failure by the Contractor to pay any subcontractor within seven calendar days of receipt of payment from the Owner for work performed that is accepted by the Owner, in violation of Section 139-F of the State Finance Law, could result in the withholding of future estimated payments by the Owner. The Contractor shall submit reports on payments made to subcontractors as required by the Owner. If it is determined by the Owner that a subcontractor has not received payment due and owing in accordance with Section 139-f of the State Finance Law, the Owner may direct the Prime Contractor to make such payment. Any such direction by the Owner is a lawful direction under Article 8 of the contract. Where such direction is not complied with, the Contractor shall not be entitled to have any estimate made for the purpose of payment nor shall any estimate be rendered on account of work done.
- N. **REQUIRED RECORDS.** The Contractor shall keep records and documents for three years following performance of this contract to indicate compliance with this Section. These records and documents, or copies thereof, will be made available at reasonable times and places for inspection by any authorized representatives of the Owner and will be submitted to the Owner upon request, together with other compliance information which may be required.

- O. NON-DISCRIMINATION. The Contractor shall not use the requirements of this Section to discriminate against any qualified company or group of companies.
- P. REPORTING VIOLATIONS OF PROGRAM RULES. The Contractor is responsible for ensuring that the DBE performs a commercially useful function on the contract as defined in Section E. If the Contractor becomes aware of any violation of this Section, the Contractor is required to promptly report the violation to the Owner.

FEDERAL AID PROJECT
DISADVANTAGED BUSINESS ENTERPRISE UTILIZATION GOALS
NEW YORK STATE DEPARTMENT OF TRANSPORTATION
DISADVANTAGED BUSINESS ENTERPRISE
UTILIZATION REQUIREMENTS

The Department has established the following Disadvantaged Business Enterprise (DBE) utilization goals for this contract. The goal is expressed as a percentage of the total bid price.

Disadvantage Business Enterprise Utilization Goal 0%

Information related to the current certification status of Disadvantaged Business Enterprises, can be obtained by contacting the:

NYS Department of Transportation
Office of Civil Rights
50 Wolf Road
POD 6-2
Albany, NY 12232
(518) 457-1128 or 457-1129

Disadvantaged Business Enterprise Officer

The bidder shall designate and enter below the name of a Disadvantaged Business Enterprise Officer who will have the responsibility for and must be capable of effectively administering and promoting an active Disadvantaged Business Enterprise Program and who must be assigned adequate authority and responsibility to do so.

Bidder Designated DBE Officer _____
(Name, Title)

Telephone Number _____

RETURN THIS PAGE WITH BID

1 OF 1

EQUAL OPPORTUNITY REQUIREMENTS FOR FEDERAL AID CONTRACTS

GENERAL. Title 23 USC Section 140(a) requires the Secretary of Transportation to ensure non-discrimination in employment generated by Federally-aided construction by the inclusion of Equal Employment Opportunity provisions in the contract specifications. Those provisions are found in the Required Contract Provisions for Federal-Aid Construction Contracts (FHWA 1273), which is incorporated into this proposal. Those provisions require the Contractor to comply with 41 CFR 60, the applicable portions of which are included in this contract. The New York State Department of Transportation is required to enforce those provisions on its Federally-aided construction contracts by 23 CFR, Part 230, Subparts A and D. Such enforcement shall include efforts on the part of the Department of Transportation to ensure that these provisions are included in, and enforced as part of, all contracts let by other agencies, including municipal subdivisions of the State, which are funded with Federal monies administered by or through the Department of Transportation. Such enforcement includes, but is not limited to, monitoring the Contractor's and Subcontractor's employment practices, requiring employment related reports to be filed by the Contractor in a timely manner on forms acceptable to the Sponsor and the Department, determining the Contractor's compliance with these provisions and taking such actions as authorized by law, rule, or regulation to enforce compliance by the Contractor. In the enforcement of those rules by the Department, the term Director means the Director of the Department's Office of Civil Rights.

Included in this contract are sections of 41 CFR 60 as required by regulation of the Office of Federal Contract Compliance Programs, and the US Department of Labor. The enforcement of those provisions is also the responsibility of the Office of Federal Contract Compliance Programs, separate and independent of the Department's enforcement responsibility.

TRAINING SPECIAL PROVISION. If this contract proposal includes the Training Special Provisions, the Contractor is required to comply with that provision as part of the Equal Employment Opportunity Requirements. The Training Special Provisions requires the Contractor to provide training to at least one minority or woman indentured apprentice or trainee. If the Contractor fails to meet the employment goals for minorities or women specified in these requirements, additional training of minorities and women will be required to satisfy the employment goals. No payment will be made for the training required of the Contractor under the Training Special Provision.

EQUAL EMPLOYMENT OPPORTUNITY OFFICER. The Contractor will designate and make known to the Sponsor and the Department an Equal Employment Opportunity Officer (EEO Officer) who will have the responsibility for, and must be capable of effectively administering and promoting, an active contractor program of Equal Employment Opportunity and who must be assigned adequate authority and responsibility to do so.

COMPLAINTS OF ALLEGED DISCRIMINATION. The Contractor will promptly investigate all complaints of alleged discrimination made to the Contractor in connection with his obligations under this contract, will attempt to resolve such complaints, and will take appropriate corrective action within a reasonable time. If the investigation indicates that the discrimination may affect persons other than the complainant, such corrective action shall include such other persons. Upon completion of each investigation, the Contractor will inform every complainant of all of his or her avenues of appeal.

ASSURANCE OF NON-DISCRIMINATION. The Sponsor, in accordance with Title VI of the Civil Rights Act of 1964, 78 Statute 252, 42 USC 2000d to 2000d-4, and Title 49, Code of Federal Regulations, Department of Transportation, Subtitle A, Office of the Secretary, Part 21, Non-Discrimination in Federally-Assisted Programs of the Department of Transportation issued pursuant to such Act, hereby notifies all Bidders that it will affirmatively ensure that in any contract entered into pursuant to this advertisement, minority business enterprises will be afforded full opportunity to submit bids in response to this invitation and will not be discriminated against on the grounds of race, color, sex, or national origin in consideration for award.

CODE OF FEDERAL REGULATIONS

Title 41 - Public Contracts, Property Management

Chapter 60 - Office of Federal Contract Compliance Programs

PART 60-1, OBLIGATIONS OF CONTRACTORS AND SUBCONTRACTORS

Subpart A, Preliminary Matters; Equal Opportunity Clause; Compliance Reports

Sec. 60-1.4 Equal opportunity clause.

During the performance of this contract, the Contractor agrees as follows:

1. The Contractor will not discriminate against any employee or applicant for employment because of race, color, religion, sex, or national origin. The Contractor will take affirmative action to ensure that applicants are employed, and that employees are treated during employment without regard to their race, color, religion, sex, or national origin. Such action shall include but not be limited to the following: employment, upgrading, demotion or transfer; recruitment or recruitment advertising; layoff or termination; rates of pay or other forms of compensation; and selection for training, including apprenticeship. The Contractor agrees to post in conspicuous places, available to employees and applicants for employment, notices to be provided setting forth the provisions of this nondiscrimination clause.
2. The Contractor will, in all solicitations or advertisements for employees placed by or on behalf of the Contractor, state that all qualified applicants will receive considerations for employment without regard to race, color, religion, sex, or national origin.
3. The Contractor will send to each labor union or representative of workers with which he has a collective bargaining agreement or other contract or understanding, a notice to be provided advising the said labor union or workers' representatives of the Contractor's commitments under this section, and shall post copies of the notice in conspicuous places available to employees and applicants for employment.
4. The Contractor will comply with all provisions of Executive Order 11246 of September 24, 1965, and of the rules, regulations, and relevant orders of the Secretary of Labor.
5. The Contractor will furnish all information and reports required by Executive Order 11246 of September 24, 1965, and by the rules, regulations, and orders of the Secretary of Labor, or pursuant thereto, and will permit access to his books, records, and accounts by the administering agency and the Secretary of Labor for purposes of investigation to ascertain compliance with such rules, regulations, and orders.
6. In the event of the Contractor's non-compliance with the nondiscrimination clauses of this contract or with any of the said rules, regulations, or orders, this contract may be canceled, terminated, or suspended in whole or in part, and the Contractor may be declared ineligible for further Government contracts or federally assisted construction contracts in accordance with procedures authorized in Executive Order 11246 of September 24, 1965, and such other sanctions may be imposed and remedies invoked as provided for in Executive Order 11246 of September 24, 1965, or by rule, regulation, or order of the Secretary of Labor, or as otherwise provided by law.

7. The Contractor will include the portion of the sentence immediately preceding paragraph (1) and the provisions of paragraph (1) through (7) in every subcontract or purchase order unless exempted by rules, regulations, or orders of the Secretary of Labor pursuant to Section 204 of Executive Order 11246 of September 24, 1965, so that such provisions will be binding upon each subcontractor or vendor. The Contractor will take such action with respect to any subcontract or purchase order as the administering agency may direct as a means of enforcing such provisions, including sanctions for non-compliance: Provided, however, that in the event a contractor becomes involved in, or is threatened with, litigation with a subcontractor or vendor as a result of such direction by the administering agency, the Contractor may request the United States to enter into such litigation to protect the interests of the United States.

PART 60-4, CONSTRUCTION CONTRACTORS, AFFIRMATIVE ACTION REQUIREMENTS

Sec. 60-4.2, Solicitations

NOTICE OF REQUIREMENT FOR AFFIRMATIVE ACTION TO ENSURE EQUAL EMPLOYMENT OPPORTUNITY (EXECUTIVE ORDER 11246)

1. The Offerer's or Bidder's attention is called to the "Equal Opportunity Clause" and the "Standard Federal Equal Employment Specifications" set forth herein.
2. The goals and timetables for minority and female participation, expressed in percentage terms for the Contractor's aggregate workforce in each trade on all construction work in the covered area, are as set forth in the solicitations from which this contract resulted.

These goals are applicable to all the Contractor's construction work (whether or not it is federal or federally assisted) performed in the covered area. If the Contractor performs construction work in a geographical area located outside of the covered area, it shall apply the goals established for such geographical area where the work is actually performed. With regard to this second area, the Contractor is also subject to the goals for both its federally involved and nonfederally involved construction.

The Contractor's compliance with the Executive Order and the regulations in 41 CFR Part 60-4 shall be based on its implementation of the Equal Opportunity Clause, specific affirmative action obligations required by specifications set forth in 41 CFR 60-4.3(a), and its efforts to meet the goals. The hours of minority and female employment and training must be substantially uniform throughout the length of the contract, and in each trade, and the Contractor shall make a good faith effort to employ minorities and women on each of its projects. The transfer of minorities or female employees or trainees from Contractor to Contractor or from project to project for the sole purpose of meeting the Contractor's goals shall be a violation of the contract, the Executive Order, and the regulations in 41 CFR Part 60-4. Compliance with the goals will be measured against the total work hours performed.

3. The Contractor shall provide written notification to the Director of the Office of Federal Contract Compliance Programs within 10 working days of award of any construction subcontract in excess of \$10,000.00 at any tier for construction work under the contract resulting from this solicitation. The notification shall list the name, address, and telephone number of the Subcontractor; employer identification number of the subcontractor; estimated dollar amount of the subcontract; estimated starting and completion dates of the subcontract; and the geographical area in which the subcontract

is to be performed.

4. As used in this Notice, and in the contract resulting from this solicitation, the "covered area" is the county where the contract is to be performed.

Sec. 60-4.3, Equal Opportunity Clauses

STANDARD FEDERAL EQUAL EMPLOYMENT OPPORTUNITY CONSTRUCTION CONTRACT SPECIFICATIONS (EXECUTIVE ORDER 11246)

1. As used in these specifications:
 - a. "Covered area" means the geographical area described in the solicitation from which this contract resulted;
 - b. "Director" means Director, Office of Federal Contract Compliance Programs, United States Department of Labor, or any person to whom the Director delegates authority;
 - c. "Employer identification number" means the Federal Social Security number used on the Employer's Quarterly Federal Tax Return, U. S. Treasury Department Form 941.
 - d. "Minority" includes:
 - (i) Black (all persons having origins in any of the Black African racial groups not of Hispanic origin);
 - (ii) Hispanic (all persons of Mexican, Puerto Rican, Cuban, Central or South American, or other Spanish Culture or origin, regardless of race);
 - (iii) Asian and Pacific Islander (all persons having origins in any of the original peoples of the Far East, Southeast Asia, the Indian Subcontinent, or the Pacific Islands); and
 - (iv) American Indian or Alaskan native (all persons having origins in any of the original peoples of North America and maintaining identifiable tribal affiliations through membership and participation or community identification).
2. Whenever the Contractor, or any Subcontractor at any tier, subcontracts a portion of the work involving any construction trade, it shall physically include in each subcontract in excess of \$10,000.00 the provisions of these specifications and the Notice which contains the applicable goals for minority and female participation and which is set forth in the solicitations from which this contract resulted.
3. If the Contractor is participating (pursuant to 41 CFR 60-4.5) in a Hometown Plan approved by the U. S. Department of Labor in the covered area either individually or through an association, its affirmative action obligations on all work in the Plan area (including goals and timetables) shall be in accordance with that Plan for those trades which have unions participating in the Plan. Contractors must be able to demonstrate their participation in and compliance with the provisions of any such Hometown Plan.

Each Contractor or Subcontractor participating in an approved Plan is individually required to comply with its obligations under the EEO clause, and to make a good faith effort to achieve each goal under the Plan in each trade in which it has employees. The overall good faith performance by other Contractors or Subcontractors toward a goal in an approved Plan does not excuse any covered Contractor's or Subcontractor's failure to make good faith efforts to achieve the Plan goals and timetables.

4. The Contractor shall implement the specific affirmative action standards provided in paragraphs 7(a) through (d) of these specifications. The goals set forth in the solicitations from which this contract resulted are expressed as percentages of the total hours of employment and training of minority and female utilization the Contractor should reasonably be able to achieve in each construction trade in which it has employees in the covered area. Covered construction contractors performing construction work in geographical areas where they do not have a federal or federally assisted construction contract shall apply the minority and female goals established for the geographic area where the work is being performed. Goals are published periodically in the FEDERAL REGISTER in notice form, and such notices may be obtained from any Office of Federal Contract Compliance Programs office or from Federal procurement contracting officers. The Contractor is expected to make substantially uniform progress in meeting its goals in each craft during the period specified.
5. Neither the provisions of any collective bargaining agreement, nor the failure by a union with whom the Contractor has a collective bargaining agreement, to refer either minorities or women shall excuse the Contractor's obligations under these specifications, Executive Order 11246, or the regulations promulgated pursuant thereto.
6. In order for the non-working training hours of apprentices and trainees to be counted in meeting the goals, such apprentices and trainees must be employed by the Contractor during the training period, and the Contractor must have made a commitment to employ the apprentices and trainees at the completion of their training, subject to the availability of employment opportunities. Trainees must be trained pursuant to training programs approved by the U. S. Department of Labor.
7. The Contractor shall take specific affirmative action's to ensure equal employment opportunity. The evaluation of the Contractor's compliance with these specifications shall be based upon its efforts to achieve maximum results from its actions. The Contractor shall document these efforts fully, and shall implement affirmative action steps at least as extensive as the following:
 - a. Ensure and maintain a working environment free of harassment, intimidation, and coercion at all sites, and in all facilities at which the Contractor's employees are assigned to work. The Contractor, where possible, will assign two or more women to each construction project. The Contractor shall specifically ensure that all foremen, superintendents, and other on-site supervisory personnel are aware of and carry out the Contractor's obligation to maintain such a working environment, with specific attention to minority or female individuals working at such sites or in such facilities.
 - b. Establish and maintain a current list of minority and female recruitment sources, provide written notification to minority and female recruitment sources and to community organizations when the Contractor or its unions have employment opportunities available, and maintain a record of the organizations' responses.

- c. Maintain a current file of the names, addresses, and telephone numbers of each minority and female off-the-street applicant and minority or female referral from a union, a recruitment source, or community organization, and of what action was taken with respect to each such individual. If such individual was sent to the union hiring hall for referral and was not referred back to the Contractor by the union, or, if referred, not employed by the Contractor, this shall be documented in the file with the reason therefore, along with whatever additional actions the Contractor may have taken.
- d. Provide immediate written notification to the Director when the union or unions with which the Contractor has a collective bargaining agreement has not referred to the Contractor a minority person or woman sent by the Contractor, or when the Contractor has other information that the union referral process has impeded the Contractor's efforts to meet its obligations.
- e. Develop on-the-job training opportunities and/or participate in training programs for the area which expressly include minorities and women, including upgrading programs and apprenticeship and trainee programs relevant to the Contractor's employment needs, especially those programs funded or approved by the Department of Labor. The Contractor shall provide notice of these programs to the sources compiled under 7(b) above.
- f. Disseminate the Contractor's EEO policy by providing notice of the policy to unions and training programs and requesting their cooperation in assisting the Contractor in meeting its EEO obligations; by including it in any policy manual and collective bargaining agreement; by publicizing in the company newspaper, annual report, etc.; by specific review of the policy with all management personnel and with all minority and female employees at least once a year; and by posting the company EEO policy on bulletin boards accessible to all employees at each location where construction work is performed.
- g. Review, at least annually, the company's EEO policy and affirmative action obligations under these specifications with all employees having any responsibility for hiring, assignment, layoff, termination, or other employment decisions including specific review of these items with on-site supervisory personnel such as superintendents, general foremen, etc., prior to the initiation of construction work at any job site. A written record shall be made and maintained identifying the time and place of these meetings, persons attending, subject matter discussed, and disposition of the subject matter.
- h. Disseminate the Contractor's EEO policy externally by including it in any advertising in the news media, specifically including minority and female news media, and providing written notification to and discussing the Contractor's EEO policy with other Contractors and Subcontractors with whom the Contractor does or anticipates doing business.
- i. Direct its recruitment efforts, both oral and written, to minority, female, and community organizations, to schools with minority and female students, and to minority and female recruitment and training organizations serving the Contractor's recruitment area and employment needs. Not later than one month prior to the date for the acceptance of applications for apprenticeship or other training by any recruitment sources, the Contractor shall send written notification to organizations such as the

above, describing the openings, screening procedures, and tests to be used in the selection process.

- j. Encourage present minority and female employees to recruit other minority persons and women and, where reasonable, provide after-school, summer, and vacation employment to minority and female youth both on the site and in other areas of a Contractor's work force.
 - k. Validate all tests and other selection requirements where there is an obligation to do so under 41 CFR Part 60-3.
 - l. Conduct, at least annually, an inventory and evaluation at least of all minority and female personnel for promotional opportunities and encourage these employees to seek or prepare for, through appropriate training, etc., such opportunities.
 - m. Ensure that seniority practices, job classifications, work assignments, and other personnel practices, do not have a discriminatory effect by continually monitoring all personnel and employment related activities to ensure that the EEO policy and the Contractor's obligations under these specifications are being carried out.
 - n. Ensure that all facilities and company activities are non-segregated except that separate or single user toilet and necessary changing facilities shall be provided to assure privacy between the sexes.
 - o. Document and maintain a record of all solicitations of offers of subcontracts from minority and female construction contractors and suppliers, including circulation of solicitations to minority and female contractor associations and other business associations.
 - p. Conduct a review, at least annually, of all supervisors' adherence to and performance under the Contractor's EEO policies and affirmative action obligations.
8. Contractors are encouraged to participate in voluntary associations which assist in fulfilling one or more of their affirmative action obligations (7 (a) through (p)). The efforts of a contractor association, joint contractor union, contractor-community, or other similar group of which the contractor is a member and participant, may be asserted as fulfilling any one or more of its obligations under sections 7(a) through 7(p) of these specifications provided that the Contractor actively participates in the group, makes every effort to assure that the group has a positive impact on the employment of minorities and women in the industry, ensures that the concrete benefits of the program are reflected in the Contractor's minority and female workforce participation, makes a good faith effort to meet its individual goals and timetables, and can provide access to documentation which demonstrates the effectiveness of actions taken on behalf of the Contractor. The obligation to comply, however, is the Contractor's, and failure of such a group to fulfill an obligation shall not be a defense for the Contractor's non-compliance.
9. A single goal for minorities and a separate single goal for women have been established. The Contractor, however, is required to provide equal employment opportunity and to take affirmative action for all minority groups, both male and female, and all women, both minority and non-minority. Consequently, the Contractor may be in violation of the Executive Order if a particular group is employed in a substantially disparate manner (for example, even though the Contractor has achieved its goal for women generally, the

Contractor may be in violation of the Executive Order if a specific group of minority women is underutilized).

10. The Contractor shall not use the goals and timetables of affirmative action standards to discriminate against any person because of race, color, religion, or national origin.
11. The Contractor shall not enter into any subcontract with any person or firm debarred from Government contracts pursuant to Executive Order 11246.
12. The Contractor shall carry out such sanctions and penalties for violation of these specifications and of the Equal Opportunity Clause, including suspension, termination, and cancellation of existing subcontracts as may be imposed or ordered pursuant to Executive Order 11246, as amended, and its implementing regulations, by the Office of Federal Contract Compliance Programs. Any Contractor who fails to carry out such sanctions and penalties shall be in violation of these specifications and Executive Order 11246, as amended.
13. The Contractor, in fulfilling its obligation under these specifications, shall implement specific affirmative action steps, at least as extensive as those standards prescribed in paragraph 7 of these specifications, so as to achieve maximum results from its efforts to ensure equal employment opportunity. If the Contractor fails to comply with the requirements of the Executive Order, the implementing regulations, or these specifications, the Director shall proceed in accordance with 41 CFR 60-4.3.
14. The Contractor shall designate a responsible official to monitor all employment related activity to ensure that the company EEO policy is being carried out, to submit reports relating to the provisions hereof as may be required by the Government, and to keep records. Records shall at least include for each employee the name, address, telephone numbers, construction trade, union affiliation, if any, employee identification number when assigned, social security number, race, sex, status (e.g., mechanic, apprentice trainer, helper, or laborer), dates of changes in status, hours worked per week in the indicated trade, rate of pay, and location at which the work was performed. Records shall be maintained in an easily understandable and retrievable form; however, to the degree that existing records satisfy this requirement, contractors shall not be required to maintain separate records.
15. Nothing herein provided shall be construed as a limitation upon the application of other laws which establish different standards of compliance or upon the application of requirements for the hiring of local or other area residents (e.g., those under the Public Works Employment Act of 1977 and the Community Development Block Grant Program).

Sec. 60-4.5, Hometown plans.

1. A contractor participating, either individually or through an association, in an approved Hometown Plan (including heavy highway affirmative action plans) shall comply with its affirmative action obligations under Executive Order 11246 by complying with its obligations under the Plan: Provided, that each contractor or subcontractor participating in an approved plan is individually required to comply with the equal opportunity clause set forth in 41 CFR 60-1.4; to make a good faith effort to achieve the goals for each trade participating in the plan in which it has employees; and that the overall good performance by other contractors or subcontractors toward a goal in an approved plan

does not excuse any covered contractor's or subcontractor's failure to take good faith efforts to achieve the plan's goals and timetables. If a contractor is not participating in an approved Hometown Plan it shall comply with the specifications set forth in ' 60-4.3 of this part, and with the goals and timetables for the appropriate area as listed in the notice required by 41 CFR 60-4.2 with regard to that trade. For the purposes of this part 60-4, a Contractor is not participating in a Hometown Plan for a particular trade if it:

- i. Ceases to be signatory to a Hometown Plan covering that trade;
- ii. Is signatory to a Hometown Plan for that trade but is not party to a collective bargaining agreement for that trade;
- iii. Is signatory to a Hometown Plan for that trade but is party to a collective bargaining agreement with labor organizations which are not or cease to be signatories to the same Hometown Plan for that trade;
- iv. Is signatory to a Hometown Plan for that trade and is party to a collective bargaining agreement with a labor organization for that trade but the two have not jointly executed a specific commitment to minority and female goals and timetables and incorporated the commitment in the Hometown Plan for that trade;
- v. Is participating in a Hometown Plan for that trade which is no longer acceptable to the Office of Federal Contract Compliance Programs;
- vi. Is signatory to a Hometown Plan for that trade but is party to a collective bargaining agreement with a labor organization for that trade and the labor organization and the contractor have failed to make a good faith effort to comply with their obligations under the Hometown Plan for that trade.

2. Contractors participating in Hometown Plans must be able to demonstrate their participation and document their compliance with the provisions of the Hometown Plan.

Sec. 60-4.6, Goals and timetables.

The Director, from time to time, shall issue goals and timetables for minority and female utilization which shall be based on appropriate workforce, demographic, or other relevant data and which shall cover construction projects or construction contracts performed in specific geographical areas. The goals, which shall be applicable to each construction trade in a covered contractor's or subcontractor's entire workforce which is working in the area covered by the goals and timetables, shall be published as notices in the FEDERAL REGISTER, and shall be inserted by the contracting officers and applicants, as applicable, in the Notice required by 41 CFR 60-4.2. Covered construction contractors performing construction work in geographical areas where they do not have a federal or federally assisted construction contract shall apply the minority and female goals established for the geographical area where work is being performed.

Sec. 60-4.8, Show cause notice.

If an investigation or compliance review reveals that a construction contractor or subcontractor has violated the Executive Order, and contract clause, specification, or the regulations in this chapter, and if administrative enforcement is contemplated, the Director shall issue to the Contractor or Subcontractor a notice to show cause which shall contain the items specified in paragraphs (i) through (iv) of 41 CFR 60-2.2(c)(1). If the Contractor does not show good cause within 30 days, or in the alternative, fails to enter an acceptable conciliation agreement which includes, where appropriate, make up goals and timetables, back pay, and seniority relief for

affected class members, the OFCCP shall follow the procedure in 41 CFR 60-1.26(b): Provided, that where a conciliation agreement has been violated, no show cause notice is required prior to the initiation of the enforcement proceedings.

Sec. 60-4.9, Incorporation by operation of the order.

By operation of the order, the equal opportunity clause contained in Sec. 60-1.4, the Notice of Requirement for Affirmative Action to Ensure Equal Employment Opportunity (Executive Order 11246) contained in Sec. 60-4.2 and the Standard Federal Equal Employment Opportunity Construction Contract Specifications (Executive Order 11246) contained in Sec. 60-4.3 shall be deemed to be a part of every solicitation or of every contract and subcontract, as appropriate, required by the order and the regulations in this chapter to include such clauses whether or not they are physically incorporated in such solicitation or contract and whether or not the contract is written.

GOALS FOR MINORITY PARTICIPATION IN THE CONSTRUCTION INDUSTRY

COUNTY	% GOAL	COUNTY	% GOAL	COUNTY	% GOAL
Albany	3.2	Herkimer	2.1	Richmond	*
Allegany	6.3	Jefferson	2.5	Rockland	22.6
Broome	1.1	Kings	*	St. Lawrence	2.5
Bronx	*	Lewis	2.5	Saratoga	3.2
Cattaraugus	6.3	Livingston	5.3	Schenectady	3.2
Cayuga	2.5	Madison	3.8	Schoharie	2.6
Chautauqua	6.3	Monroe	5.3	Schuyler	1.2
Chemung	2.2	Montgomery	3.2	Seneca	5.9
Chenango	1.2	Nassau	5.8	Steuben	1.2
Clinton	2.6	New York	*	Suffolk	5.8
Columbia	2.6	Niagara	7.7	Sullivan	17.0
Cortland	2.5	Oneida	2.1	Tioga	1.1
Delaware	1.2	Onondaga	3.8	Tompkins	1.2
Dutchess	6.4	Ontario	5.3	Ulster	17.0
Erie	7.7	Orange	17.0	Warren	2.6
Essex	2.6	Orleans	5.3	Washington	2.6
Franklin	2.5	Oswego	3.8	Wayne	5.3
Fulton	2.6	Otsego	1.2	Westchester	22.6
Genesee	5.9	Putnam	22.6	Wyoming	6.3
Greene	2.6	Queens	*	Yates	5.9
Hamilton	2.6	Rensselaer	3.2		

*** The following goal ranges are applicable to the indicated trades in the Counties of Bronx, Kings, New York, Queens, and Richmond:**

Electricians.....	9.0 to 10.2
Carpenters.....	27.6 to 32.0
Steam Filters.....	2.2 to 13.5
Metal Lathers.....	26.0 to 28.6
Operating Engineers.....	25.6 to 26.0
Plumbers.....	12.0 to 14.5
Iron Workers (Structural).....	25.9 to 32.0
Elevator Constructors.....	5.5 to 6.5
Bricklayers.....	13.4 to 15.5
Asbestos Workers.....	22.8 to 28.0
Roofers.....	6.3 to 7.5
Iron Workers (Ornamental).....	22.4 to 23.0
Cement Masons.....	23.0 to 27.0
Glaziers.....	16.0 to 20.0
Plasterers.....	15.8 to 18.0
Teamsters.....	22.0 to 22.5
Boilermakers.....	13.0 to 15.5
All Others.....	16.4 to 17.5

GOALS FOR WOMEN

Female Goals - 6.9%

Goals for the utilization of women by Federal and Federally assisted construction contractors were last published on April 7, 1978 (43 CFR 4988, 149000). That April 7, 1978 publication included a 6.9% goal for the period from April 1, 1980 until March 31, 1981. Pursuant to 41 CFR 60-4.6, the 6.9% goal for female utilization is extended until further notice

REQUIRED CONTRACT PROVISIONS FEDERAL-AID CONSTRUCTION CONTRACTS

- I. General
- II. Nondiscrimination
- III. Nonsegregated Facilities
- IV. Davis-Bacon and Related Act Provisions
- V. Contract Work Hours and Safety Standards Act Provisions
- VI. Subletting or Assigning the Contract
- VII. Safety: Accident Prevention
- VIII. False Statements Concerning Highway Projects
- IX. Implementation of Clean Air Act and Federal Water Pollution Control Act
- X. Compliance with Governmentwide Suspension and Debarment Requirements
- XI. Certification Regarding Use of Contract Funds for Lobbying

ATTACHMENTS

A. Employment and Materials Preference for Appalachian Development Highway System or Appalachian Local Access Road Contracts (included in Appalachian contracts only)

I. GENERAL

1. Form FHWA-1273 must be physically incorporated in each construction contract funded under Title 23 (excluding emergency contracts solely intended for debris removal). The contractor (or subcontractor) must insert this form in each subcontract and further require its inclusion in all lower tier subcontracts (excluding purchase orders, rental agreements and other agreements for supplies or services).

The applicable requirements of Form FHWA-1273 are incorporated by reference for work done under any purchase order, rental agreement or agreement for other services. The prime contractor shall be

responsible for compliance by any subcontractor, lower-tier subcontractor or service provider.

Form FHWA-1273 must be included in all Federal-aid design-build contracts, in all subcontracts and in lower tier subcontracts (excluding subcontracts for design services, purchase orders, rental agreements and other agreements for supplies or services). The design-builder shall be responsible for compliance by any subcontractor, lower-tier subcontractor or service provider.

Contracting agencies may reference Form FHWA-1273 in bid proposal or request for proposal documents, however, the Form FHWA-1273 must be physically incorporated (not referenced) in all contracts, subcontracts and lower-tier subcontracts (excluding purchase orders, rental agreements and other agreements for supplies or services related to a construction contract).

2. Subject to the applicability criteria noted in the following sections, these contract provisions shall apply to all work performed on the contract by the contractor's own organization and with the assistance of workers under the contractor's immediate superintendence and to all work performed on the contract by piecework, station work, or by subcontract.

3. A breach of any of the stipulations contained in these Required Contract Provisions may be sufficient grounds for withholding of progress payments, withholding of final payment, termination of the contract, suspension / debarment or any other action determined to be appropriate by the contracting agency and FHWA.

4. Selection of Labor: During the

performance of this contract, the contractor shall not use convict labor for any purpose within the limits of a construction project on a Federal-aid highway unless it is labor performed by convicts who are on parole, supervised release, or probation. The term Federal-aid highway does not include roadways functionally classified as local roads or rural minor collectors.

II. NONDISCRIMINATION

The provisions of this section related to 23 CFR Part 230 are applicable to all Federal-aid construction contracts and to all related construction subcontracts of \$10,000 or more. The provisions of 23 CFR Part 230 are not applicable to material supply, engineering, or architectural service contracts.

In addition, the contractor and all subcontractors must comply with the following policies: Executive Order 11246, 41 CFR 60, 29 CFR 1625-1627, Title 23 USC Section 140, the Rehabilitation Act of 1973, as amended (29 USC 794), Title VI of the Civil Rights Act of 1964, as amended, and related regulations including 49 CFR Parts 21, 26 and 27; and 23 CFR Parts 200, 230, and 633.

The contractor and all subcontractors must comply with: the requirements of the Equal Opportunity Clause in 41 CFR 60-1.4(b) and, for all construction contracts exceeding \$10,000, the Standard Federal Equal Employment Opportunity Construction Contract Specifications in 41 CFR 60-4.3.

Note: The U.S. Department of Labor has exclusive authority to determine compliance with Executive Order 11246 and the policies of the Secretary of Labor including 41 CFR 60, and 29 CFR 1625-1627. The contracting agency and the FHWA have the authority and the responsibility to ensure compliance with Title 23 USC Section 140, the Rehabilitation Act of 1973, as amended (29 USC 794), and Title VI of the Civil Rights Act of 1964, as amended, and related regulations including 49 CFR Parts

21, 26 and 27; and 23 CFR Parts 200, 230, and 633.

The following provision is adopted from 23 CFR 230, Appendix A, with appropriate revisions to conform to the U.S. Department of Labor (US DOL) and FHWA requirements.

1. Equal Employment Opportunity: Equal employment opportunity (EEO) requirements not to discriminate and to take affirmative action to assure equal opportunity as set forth under laws, executive orders, rules, regulations (28 CFR 35, 29 CFR 1630, 29 CFR 1625-1627, 41 CFR 60 and 49 CFR 27) and orders of the Secretary of Labor as modified by the provisions prescribed herein, and imposed pursuant to 23 U.S.C. 140 shall constitute the EEO and specific affirmative action standards for the contractor's project activities under this contract. The provisions of the Americans with Disabilities Act of 1990 (42 U.S.C. 12101 et seq.) set forth under 28 CFR 35 and 29 CFR 1630 are incorporated by reference in this contract. In the execution of this contract, the contractor agrees to comply with the following minimum specific requirement activities of EEO:

a. The contractor will work with the contracting agency and the Federal Government to ensure that it has made every good faith effort to provide equal opportunity with respect to all of its terms and conditions of employment and in their review of activities under the contract.

b. The contractor will accept as its operating policy the following statement:

"It is the policy of this Company to assure that applicants are employed, and that employees are treated during employment, without regard to their race, religion, sex, color, national origin, age or disability. Such action shall include: employment, upgrading, demotion, or transfer; recruitment or recruitment advertising; layoff or termination; rates of

pay or other forms of compensation; and selection for training, including apprenticeship, pre-apprenticeship, and/or on-the-job training."

2. EEO Officer: The contractor will designate and make known to the contracting officers an EEO Officer who will have the responsibility for and must be capable of effectively administering and promoting an active EEO program and who must be assigned adequate authority and responsibility to do so.

3. Dissemination of Policy: All members of the contractor's staff who are authorized to hire, supervise, promote, and discharge employees, or who recommend such action, or who are substantially involved in such action, will be made fully cognizant of, and will implement, the contractor's EEO policy and contractual responsibilities to provide EEO in each grade and classification of employment. To ensure that the above agreement will be met, the following actions will be taken as a minimum:

a. Periodic meetings of supervisory and personnel office employees will be conducted before the start of work and then not less often than once every six months, at which time the contractor's EEO policy and its implementation will be reviewed and explained. The meetings will be conducted by the EEO Officer.

b. All new supervisory or personnel office employees will be given a thorough indoctrination by the EEO Officer, covering all major aspects of the contractor's EEO obligations within thirty days following their reporting for duty with the contractor.

c. All personnel who are engaged in direct recruitment for the project will be instructed by the EEO Officer in the contractor's procedures for locating and hiring minorities and women.

d. Notices and posters setting forth the contractor's EEO policy will be placed in areas readily accessible to employees,

applicants for employment and potential employees.

e. The contractor's EEO policy and the procedures to implement such policy will be brought to the attention of employees by means of meetings, employee handbooks, or other appropriate means.

4. Recruitment: When advertising for employees, the contractor will include in all advertisements for employees the notation: "An Equal Opportunity Employer." All such advertisements will be placed in publications having a large circulation among minorities and women in the area from which the project work force would normally be derived.

a. The contractor will, unless precluded by a valid bargaining agreement, conduct systematic and direct recruitment through public and private employee referral sources likely to yield qualified minorities and women. To meet this requirement, the contractor will identify sources of potential minority group employees, and establish with such identified sources procedures whereby minority and women applicants may be referred to the contractor for employment consideration.

b. In the event the contractor has a valid bargaining agreement providing for exclusive hiring hall referrals, the contractor is expected to observe the provisions of that agreement to the extent that the system meets the contractor's compliance with EEO contract provisions. Where implementation of such an agreement has the effect of discriminating against minorities or women, or obligates the contractor to do the same, such implementation violates Federal nondiscrimination provisions.

c. The contractor will encourage its present employees to refer minorities and women as applicants for employment. Information and procedures with regard to referring such applicants will be discussed with employees.

5. Personnel Actions: Wages, working conditions, and employee benefits shall be established and administered, and personnel actions of every type, including hiring, upgrading, promotion, transfer, demotion, layoff, and termination, shall be taken without regard to race, color, religion, sex, national origin, age or disability. The following procedures shall be followed:

- a. The contractor will conduct periodic inspections of project sites to insure that working conditions and employee facilities do not indicate discriminatory treatment of project site personnel.
- b. The contractor will periodically evaluate the spread of wages paid within each classification to determine any evidence of discriminatory wage practices.
- c. The contractor will periodically review selected personnel actions in depth to determine whether there is evidence of discrimination. Where evidence is found, the contractor will promptly take corrective action. If the review indicates that the discrimination may extend beyond the actions reviewed, such corrective action shall include all affected persons.
- d. The contractor will promptly investigate all complaints of alleged discrimination made to the contractor in connection with its obligations under this contract, will attempt to resolve such complaints, and will take appropriate corrective action within a reasonable time. If the investigation indicates that the discrimination may affect persons other than the complainant, such corrective action shall include such other persons. Upon completion of each investigation, the contractor will inform every complainant of all of their avenues of appeal.

6. Training and Promotion:

- a. The contractor will assist in locating, qualifying, and increasing the skills of minorities and women who are applicants for employment or current employees.

Such efforts should be aimed at developing full journey level status employees in the type of trade or job classification involved.

- b. Consistent with the contractor's work force requirements and as permissible under Federal and State regulations, the contractor shall make full use of training programs, i.e., apprenticeship, and on-the-job training programs for the geographical area of contract performance. In the event a special provision for training is provided under this contract, this subparagraph will be superseded as indicated in the special provision. The contracting agency may reserve training positions for persons who receive welfare assistance in accordance with 23 U.S.C. 140(a).

- c. The contractor will advise employees and applicants for employment of available training programs and entrance requirements for each.

- d. The contractor will periodically review the training and promotion potential of employees who are minorities and women and will encourage eligible employees to apply for such training and promotion.

7. Unions: If the contractor relies in whole or in part upon unions as a source of employees, the contractor will use good faith efforts to obtain the cooperation of such unions to increase opportunities for minorities and women. Actions by the contractor, either directly or through a contractor's association acting as agent, will include the procedures set forth below:

- a. The contractor will use good faith efforts to develop, in cooperation with the unions, joint training programs aimed toward qualifying more minorities and women for membership in the unions and increasing the skills of minorities and women so that they may qualify for higher paying employment.

- b. The contractor will use good faith efforts to incorporate an EEO clause into each union agreement to the end that such

union will be contractually bound to refer applicants without regard to their race, color, religion, sex, national origin, age or disability.

c. The contractor is to obtain information as to the referral practices and policies of the labor union except that to the extent such information is within the exclusive possession of the labor union and such labor union refuses to furnish such information to the contractor, the contractor shall so certify to the contracting agency and shall set forth what efforts have been made to obtain such information.

d. In the event the union is unable to provide the contractor with a reasonable flow of referrals within the time limit set forth in the collective bargaining agreement, the contractor will, through independent recruitment efforts, fill the employment vacancies without regard to race, color, religion, sex, national origin, age or disability; making full efforts to obtain qualified and/or qualifiable minorities and women. The failure of a union to provide sufficient referrals (even though it is obligated to provide exclusive referrals under the terms of a collective bargaining agreement) does not relieve the contractor from the requirements of this paragraph. In the event the union referral practice prevents the contractor from meeting the obligations pursuant to Executive Order 11246, as amended, and these special provisions, such contractor shall immediately notify the contracting agency.

8. Reasonable Accommodation for Applicants / Employees with Disabilities:

The contractor must be familiar with the requirements for and comply with the Americans with Disabilities Act and all rules and regulations established there under. Employers must provide reasonable accommodation in all employment activities unless to do so would cause an undue hardship.

9. Selection of Subcontractors, Procurement of Materials and Leasing of

Equipment: The contractor shall not discriminate on the grounds of race, color, religion, sex, national origin, age or disability in the selection and retention of subcontractors, including procurement of materials and leases of equipment. The contractor shall take all necessary and reasonable steps to ensure nondiscrimination in the administration of this contract.

a. The contractor shall notify all potential subcontractors and suppliers and lessors of their EEO obligations under this contract.

b. The contractor will use good faith efforts to ensure subcontractor compliance with their EEO obligations.

10. Assurance Required by 49 CFR 26.13(b):

a. The requirements of 49 CFR Part 26 and the State DOT's U.S. DOT-approved DBE program are incorporated by reference.

b. The contractor or subcontractor shall not discriminate on the basis of race, color, national origin, or sex in the performance of this contract. The contractor shall carry out applicable requirements of 49 CFR Part 26 in the award and administration of DOT-assisted contracts. Failure by the contractor to carry out these requirements is a material breach of this contract, which may result in the termination of this contract or such other remedy as the contracting agency deems appropriate.

11. Records and Reports: The contractor shall keep such records as necessary to document compliance with the EEO requirements. Such records shall be retained for a period of three years following the date of the final payment to the contractor for all contract work and shall be available at reasonable times and places for inspection by authorized representatives of the contracting agency and the FHWA.

a. The records kept by the contractor shall document the following:

(1) The number and work hours of minority and non-minority group members and women employed in each work classification on the project;

(2) The progress and efforts being made in cooperation with unions, when applicable, to increase employment opportunities for minorities and women; and

(3) The progress and efforts being made in locating, hiring, training, qualifying, and upgrading minorities and women;

b. The contractors and subcontractors will submit an annual report to the contracting agency each July for the duration of the project, indicating the number of minority, women, and non-minority group employees currently engaged in each work classification required by the contract work. This information is to be reported on [Form FHWA-1391](#). The staffing data should represent the project work force on board in all or any part of the last payroll period preceding the end of July. If on-the-job training is being required by special provision, the contractor will be required to collect and report training data. The employment data should reflect the work force on board during all or any part of the last payroll period preceding the end of July.

III. NONSEGREGATED FACILITIES

This provision is applicable to all Federal-aid construction contracts and to all related construction subcontracts of \$10,000 or more.

The contractor must ensure that facilities provided for employees are provided in such a manner that segregation on the basis of race, color, religion, sex, or national origin cannot result. The contractor may neither require such segregated use by written or oral policies nor tolerate such use by employee custom. The contractor's obligation extends further to ensure that its

employees are not assigned to perform their services at any location, under the contractor's control, where the facilities are segregated. The term "facilities" includes waiting rooms, work areas, restaurants and other eating areas, time clocks, restrooms, washrooms, locker rooms, and other storage or dressing areas, parking lots, drinking fountains, recreation or entertainment areas, transportation, and housing provided for employees. The contractor shall provide separate or single-user restrooms and necessary dressing or sleeping areas to assure privacy between sexes.

IV. DAVIS-BACON AND RELATED ACT PROVISIONS

This section is applicable to all Federal-aid construction projects exceeding \$2,000 and to all related subcontracts and lower-tier subcontracts (regardless of subcontract size). The requirements apply to all projects located within the right-of-way of a roadway that is functionally classified as Federal-aid highway. This excludes roadways functionally classified as local roads or rural minor collectors, which are exempt. Contracting agencies may elect to apply these requirements to other projects. The following provisions are from the U.S. Department of Labor regulations in 29 CFR 5.5 "Contract provisions and related matters" with minor revisions to conform to the FHWA-1273 format and FHWA program requirements.

1. Minimum wages

a. All laborers and mechanics employed or working upon the site of the work, will be paid unconditionally and not less often than once a week, and without subsequent deduction or rebate on any account (except such payroll deductions as are permitted by regulations issued by the Secretary of Labor under the Copeland Act (29 CFR part 3)), the full amount of wages and bona fide fringe benefits (or cash equivalents thereof) due at time of payment computed at rates not less than those contained in the wage determination of the Secretary of Labor

which is attached hereto and made a part hereof, regardless of any contractual relationship which may be alleged to exist between the contractor and such laborers and mechanics.

Contributions made or costs reasonably anticipated for bona fide fringe benefits under section 1(b)(2) of the Davis-Bacon Act on behalf of laborers or mechanics are considered wages paid to such laborers or mechanics, subject to the provisions of paragraph 1.d. of this section; also, regular contributions made or costs incurred for more than a weekly period (but not less often than quarterly) under plans, funds, or programs which cover the particular weekly period, are deemed to be constructively made or incurred during such weekly period. Such laborers and mechanics shall be paid the appropriate wage rate and fringe benefits on the wage determination for the classification of work actually performed, without regard to skill, except as provided in 29 CFR 5.5(a)(4). Laborers or mechanics performing work in more than one classification may be compensated at the rate specified for each classification for the time actually worked therein: Provided, That the employer's payroll records accurately set forth the time spent in each classification in which work is performed. The wage determination (including any additional classification and wage rates conformed under paragraph 1.b. of this section) and the Davis-Bacon poster (WH-1321) shall be posted at all times by the contractor and its subcontractors at the site of the work in a prominent and accessible place where it can be easily seen by the workers.

b. (1) The contracting officer shall require that any class of laborers or mechanics, including helpers, which is not listed in the wage determination and which is to be employed under the contract shall be classified in conformance with the wage determination. The contracting officer shall approve an additional classification and wage rate and fringe benefits therefore only when the following criteria have been met:

(i) The work to be performed by the classification requested is not performed by a classification in the wage determination; and

(ii) The classification is utilized in the area by the construction industry; and

(iii) The proposed wage rate, including any bona fide fringe benefits, bears a reasonable relationship to the wage rates contained in the wage determination.

(2) If the contractor and the laborers and mechanics to be employed in the classification (if known), or their representatives, and the contracting officer agree on the classification and wage rate (including the amount designated for fringe benefits where appropriate), a report of the action taken shall be sent by the contracting officer to the Administrator of the Wage and Hour Division, Employment Standards Administration, U.S. Department of Labor, Washington, DC 20210. The Administrator, or an authorized representative, will approve, modify, or disapprove every additional classification action within 30 days of receipt and so advise the contracting officer or will notify the contracting officer within the 30-day period that additional time is necessary.

(3) In the event the contractor, the laborers or mechanics to be employed in the classification or their representatives, and the contracting officer do not agree on the proposed classification and wage rate (including the amount designated for fringe benefits, where appropriate), the contracting officer shall refer the questions, including the views of all interested parties and the recommendation of the contracting officer, to the Wage and Hour Administrator for determination. The Wage and Hour Administrator, or an authorized representative, will issue a determination within 30 days of receipt and so advise the contracting officer or will notify the

contracting officer within the 30-day period that additional time is necessary.

(4) The wage rate (including fringe benefits where appropriate) determined pursuant to paragraphs 1.b.(2) or 1.b.(3) of this section, shall be paid to all workers performing work in the classification under this contract from the first day on which work is performed in the classification.

c. Whenever the minimum wage rate prescribed in the contract for a class of laborers or mechanics includes a fringe benefit which is not expressed as an hourly rate, the contractor shall either pay the benefit as stated in the wage determination or shall pay another bona fide fringe benefit or an hourly cash equivalent thereof.

d. If the contractor does not make payments to a trustee or other third person, the contractor may consider as part of the wages of any laborer or mechanic the amount of any costs reasonably anticipated in providing bona fide fringe benefits under a plan or program, Provided, That the Secretary of Labor has found, upon the written request of the contractor, that the applicable standards of the Davis-Bacon Act have been met. The Secretary of Labor may require the contractor to set aside in a separate account assets for the meeting of obligations under the plan or program.

2. Withholding

The contracting agency shall upon its own action or upon written request of an authorized representative of the Department of Labor, withhold or cause to be withheld from the contractor under this contract, or any other Federal contract with the same prime contractor, or any other federally-assisted contract subject to Davis-Bacon prevailing wage requirements, which is held by the same prime contractor, so much of the accrued payments or advances as may be considered necessary to pay laborers and mechanics, including apprentices, trainees, and helpers, employed by the contractor or any subcontractor the full

amount of wages required by the contract. In the event of failure to pay any laborer or mechanic, including any apprentice, trainee, or helper, employed or working on the site of the work, all or part of the wages required by the contract, the contracting agency may, after written notice to the contractor, take such action as may be necessary to cause the suspension of any further payment, advance, or guarantee of funds until such violations have ceased.

3. Payrolls and basic records

a. Payrolls and basic records relating thereto shall be maintained by the contractor during the course of the work and preserved for a period of three years thereafter for all laborers and mechanics working at the site of the work. Such records shall contain the name, address, and social security number of each such worker, his or her correct classification, hourly rates of wages paid (including rates of contributions or costs anticipated for bona fide fringe benefits or cash equivalents thereof of the types described in section 1(b)(2)(B) of the Davis-Bacon Act), daily and weekly number of hours worked, deductions made and actual wages paid. Whenever the Secretary of Labor has found under 29 CFR 5.5(a)(1)(iv) that the wages of any laborer or mechanic include the amount of any costs reasonably anticipated in providing benefits under a plan or program described in section 1(b)(2)(B) of the Davis-Bacon Act, the contractor shall maintain records which show that the commitment to provide such benefits is enforceable, that the plan or program is financially responsible, and that the plan or program has been communicated in writing to the laborers or mechanics affected, and records which show the costs anticipated or the actual cost incurred in providing such benefits. Contractors employing apprentices or trainees under approved programs shall maintain written evidence of the registration of apprenticeship programs and certification of trainee programs, the registration of the apprentices and trainees, and the ratios and wage rates prescribed in the applicable

programs.

b. (1) The contractor shall submit weekly for each week in which any contract work is performed a copy of all payrolls to the contracting agency. The payrolls submitted shall set out accurately and completely all of the information required to be maintained under 29 CFR 5.5(a)(3)(i), except that full social security numbers and home addresses shall not be included on weekly transmittals. Instead the payrolls shall only need to include an individually identifying number for each employee (e.g. , the last four digits of the employee's social security number). The required weekly payroll information may be submitted in any form desired. Optional Form WH-347 is available for this purpose from the Wage and Hour Division Web site at <http://www.dol.gov/esa/whd/forms/wh347instr.htm> or its successor site. The prime contractor is responsible for the submission of copies of payrolls by all subcontractors. Contractors and subcontractors shall maintain the full social security number and current address of each covered worker, and shall provide them upon request to the contracting agency for transmission to the State DOT, the FHWA or the Wage and Hour Division of the Department of Labor for purposes of an investigation or audit of compliance with prevailing wage requirements. It is not a violation of this section for a prime contractor to require a subcontractor to provide addresses and social security numbers to the prime contractor for its own records, without weekly submission to the contracting agency..

(2) Each payroll submitted shall be accompanied by a "Statement of Compliance," signed by the contractor or subcontractor or his or her agent who pays or supervises the payment of the persons employed under the contract and shall certify the following:

(i) That the payroll for the payroll period contains the information required to be provided under §5.5 (a)(3)(ii) of

Regulations, 29 CFR part 5, the appropriate information is being maintained under §5.5 (a)(3)(i) of Regulations, 29 CFR part 5, and that such information is correct and complete;

(ii) That each laborer or mechanic (including each helper, apprentice, and trainee) employed on the contract during the payroll period has been paid the full weekly wages earned, without rebate, either directly or indirectly, and that no deductions have been made either directly or indirectly from the full wages earned, other than permissible deductions as set forth in Regulations, 29 CFR part 3;

(iii) That each laborer or mechanic has been paid not less than the applicable wage rates and fringe benefits or cash equivalents for the classification of work performed, as specified in the applicable wage determination incorporated into the contract.

(3) The weekly submission of a properly executed certification set forth on the reverse side of Optional Form WH-347 shall satisfy the requirement for submission of the "Statement of Compliance" required by paragraph 3.b.(2) of this section.

(4) The falsification of any of the above certifications may subject the contractor or subcontractor to civil or criminal prosecution under section 1001 of title 18 and section 231 of title 31 of the United States Code.

c. The contractor or subcontractor shall make the records required under paragraph 3.a. of this section available for inspection, copying, or transcription by authorized representatives of the contracting agency, the State DOT, the FHWA, or the Department of Labor, and shall permit such representatives to interview employees during working hours on the job. If the contractor or subcontractor fails to submit the required records or to make them

available, the FHWA may, after written notice to the contractor, the contracting agency or the State DOT, take such action as may be necessary to cause the suspension of any further payment, advance, or guarantee of funds. Furthermore, failure to submit the required records upon request or to make such records available may be grounds for debarment action pursuant to 29 CFR 5.12.

4. Apprentices and trainees

a. Apprentices (programs of the USDOL).

Apprentices will be permitted to work at less than the predetermined rate for the work they performed when they are employed pursuant to and individually registered in a bona fide apprenticeship program registered with the U.S. Department of Labor, Employment and Training Administration, Office of Apprenticeship Training, Employer and Labor Services, or with a State Apprenticeship Agency recognized by the Office, or if a person is employed in his or her first 90 days of probationary employment as an apprentice in such an apprenticeship program, who is not individually registered in the program, but who has been certified by the Office of Apprenticeship Training, Employer and Labor Services or a State Apprenticeship Agency (where appropriate) to be eligible for probationary employment as an apprentice.

The allowable ratio of apprentices to journeymen on the job site in any craft classification shall not be greater than the ratio permitted to the contractor as to the entire work force under the registered program. Any worker listed on a payroll at an apprentice wage rate, who is not registered or otherwise employed as stated above, shall be paid not less than the applicable wage rate on the wage determination for the classification of work actually performed. In addition, any apprentice performing work on the job site in excess of the ratio permitted under the registered program shall be paid not less

than the applicable wage rate on the wage determination for the work actually performed. Where a contractor is performing construction on a project in a locality other than that in which its program is registered, the ratios and wage rates (expressed in percentages of the journeyman's hourly rate) specified in the contractor's or subcontractor's registered program shall be observed.

Every apprentice must be paid at not less than the rate specified in the registered program for the apprentice's level of progress, expressed as a percentage of the journeymen hourly rate specified in the applicable wage determination. Apprentices shall be paid fringe benefits in accordance with the provisions of the apprenticeship program. If the apprenticeship program does not specify fringe benefits, apprentices must be paid the full amount of fringe benefits listed on the wage determination for the applicable classification. If the Administrator determines that a different practice prevails for the applicable apprentice classification, fringes shall be paid in accordance with that determination. In the event the Office of Apprenticeship Training, Employer and Labor Services, or a State Apprenticeship Agency recognized by the Office, withdraws approval of an apprenticeship program, the contractor will no longer be permitted to utilize apprentices at less than the applicable predetermined rate for the work performed until an acceptable program is approved.

b. Trainees (programs of the USDOL).

Except as provided in 29 CFR 5.16, trainees will not be permitted to work at less than the predetermined rate for the work performed unless they are employed pursuant to and individually registered in a program which has received prior approval, evidenced by formal certification by the U.S. Department of Labor, Employment and Training Administration.

The ratio of trainees to journeymen on the job site shall not be greater than permitted

under the plan approved by the Employment and Training Administration.

Every trainee must be paid at not less than the rate specified in the approved program for the trainee's level of progress, expressed as a percentage of the journeyman hourly rate specified in the applicable wage determination. Trainees shall be paid fringe benefits in accordance with the provisions of the trainee program. If the trainee program does not mention fringe benefits, trainees shall be paid the full amount of fringe benefits listed on the wage determination unless the Administrator of the Wage and Hour Division determines that there is an apprenticeship program associated with the corresponding journeyman wage rate on the wage determination which provides for less than full fringe benefits for apprentices. Any employee listed on the payroll at a trainee rate who is not registered and participating in a training plan approved by the Employment and Training Administration shall be paid not less than the applicable wage rate on the wage determination for the classification of work actually performed. In addition, any trainee performing work on the job site in excess of the ratio permitted under the registered program shall be paid not less than the applicable wage rate on the wage determination for the work actually performed.

In the event the Employment and Training Administration withdraws approval of a training program, the contractor will no longer be permitted to utilize trainees at less than the applicable predetermined rate for the work performed until an acceptable program is approved.

c. Equal employment opportunity. The utilization of apprentices, trainees and journeymen under this part shall be in conformity with the equal employment opportunity requirements of Executive Order 11246, as amended, and 29 CFR part 30.

d. Apprentices and Trainees (programs of the U.S. DOT).

Apprentices and trainees working under apprenticeship and skill training programs which have been certified by the Secretary of Transportation as promoting EEO in connection with Federal-aid highway construction programs are not subject to the requirements of paragraph 4 of this Section IV. The straight time hourly wage rates for apprentices and trainees under such programs will be established by the particular programs. The ratio of apprentices and trainees to journeymen shall not be greater than permitted by the terms of the particular program.

5. Compliance with Copeland Act requirements. The contractor shall comply with the requirements of 29 CFR part 3, which are incorporated by reference in this contract.

6. Subcontracts. The contractor or subcontractor shall insert Form FHWA-1273 in any subcontracts and also require the subcontractors to include Form FHWA-1273 in any lower tier subcontracts. The prime contractor shall be responsible for the compliance by any subcontractor or lower tier subcontractor with all the contract clauses in 29 CFR 5.5.

7. Contract termination: debarment. A breach of the contract clauses in 29 CFR 5.5 may be grounds for termination of the contract, and for debarment as a contractor and a subcontractor as provided in 29 CFR 5.12.

8. Compliance with Davis-Bacon and Related Act requirements. All rulings and interpretations of the Davis-Bacon and Related Acts contained in 29 CFR parts 1, 3, and 5 are herein incorporated by reference in this contract.

9. Disputes concerning labor standards. Disputes arising out of the labor standards provisions of this contract shall not be subject to the general disputes clause of this contract. Such disputes shall be resolved in accordance with the procedures

of the Department of Labor set forth in 29 CFR parts 5, 6, and 7. Disputes within the meaning of this clause include disputes between the contractor (or any of its subcontractors) and the contracting agency, the U.S. Department of Labor, or the employees or their representatives.

10. Certification of eligibility.

a. By entering into this contract, the contractor certifies that neither it (nor he or she) nor any person or firm who has an interest in the contractor's firm is a person or firm ineligible to be awarded Government contracts by virtue of section 3(a) of the Davis-Bacon Act or 29 CFR 5.12(a)(1).

b. No part of this contract shall be subcontracted to any person or firm ineligible for award of a Government contract by virtue of section 3(a) of the Davis-Bacon Act or 29 CFR 5.12(a)(1).

c. The penalty for making false statements is prescribed in the U.S. Criminal Code, 18 U.S.C. 1001.

V. CONTRACT WORK HOURS AND SAFETY STANDARDS ACT

The following clauses apply to any Federal-aid construction contract in an amount in excess of \$100,000 and subject to the overtime provisions of the Contract Work Hours and Safety Standards Act. These clauses shall be inserted in addition to the clauses required by 29 CFR 5.5(a) or 29 CFR 4.6. As used in this paragraph, the terms laborers and mechanics include watchmen and guards.

1. Overtime requirements. No contractor or subcontractor contracting for any part of the contract work which may require or involve the employment of laborers or mechanics shall require or permit any such laborer or mechanic in any workweek in which he or she is employed on such work to work in excess of forty hours in such workweek unless such laborer or mechanic receives compensation at a rate not less

than one and one-half times the basic rate of pay for all hours worked in excess of forty hours in such workweek.

2. Violation; liability for unpaid wages; liquidated damages. In the event of any violation of the clause set forth in paragraph (1.) of this section, the contractor and any subcontractor responsible therefor shall be liable for the unpaid wages. In addition, such contractor and subcontractor shall be liable to the United States (in the case of work done under contract for the District of Columbia or a territory, to such District or to such territory), for liquidated damages. Such liquidated damages shall be computed with respect to each individual laborer or mechanic, including watchmen and guards, employed in violation of the clause set forth in paragraph (1.) of this section, in the sum of \$10 for each calendar day on which such individual was required or permitted to work in excess of the standard workweek of forty hours without payment of the overtime wages required by the clause set forth in paragraph (1.) of this section.

3. Withholding for unpaid wages and liquidated damages. The FHWA or the contracting agency shall upon its own action or upon written request of an authorized representative of the Department of Labor withhold or cause to be withheld, from any moneys payable on account of work performed by the contractor or subcontractor under any such contract or any other Federal contract with the same prime contractor, or any other federally-assisted contract subject to the Contract Work Hours and Safety Standards Act, which is held by the same prime contractor, such sums as may be determined to be necessary to satisfy any liabilities of such contractor or subcontractor for unpaid wages and liquidated damages as provided in the clause set forth in paragraph (2.) of this section.

4. Subcontracts. The contractor or subcontractor shall insert in any subcontracts the clauses set forth in paragraph (1.) through (4.) of this section

and also a clause requiring the subcontractors to include these clauses in any lower tier subcontracts. The prime contractor shall be responsible for compliance by any subcontractor or lower tier subcontractor with the clauses set forth in paragraphs (1.) through (4.) of this section.

VI. SUBLETTING OR ASSIGNING THE CONTRACT

This provision is applicable to all Federal-aid construction contracts on the National Highway System.

1. The contractor shall perform with its own organization contract work amounting to not less than 30 percent (or a greater percentage if specified elsewhere in the contract) of the total original contract price, excluding any specialty items designated by the contracting agency. Specialty items may be performed by subcontract and the amount of any such specialty items performed may be deducted from the total original contract price before computing the amount of work required to be performed by the contractor's own organization (23 CFR 635.116).

a. The term "perform work with its own organization" refers to workers employed or leased by the prime contractor, and equipment owned or rented by the prime contractor, with or without operators. Such term does not include employees or equipment of a subcontractor or lower tier subcontractor, agents of the prime contractor, or any other assignees. The term may include payments for the costs of hiring leased employees from an employee leasing firm meeting all relevant Federal and State regulatory requirements. Leased employees may only be included in this term if the prime contractor meets all of the following conditions:

(1) the prime contractor maintains control over the supervision of the day-to-day activities of the leased employees;

(2) the prime contractor remains responsible for the quality of the work of the leased employees;

(3) the prime contractor retains all power to accept or exclude individual employees from work on the project; and

(4) the prime contractor remains ultimately responsible for the payment of predetermined minimum wages, the submission of payrolls, statements of compliance and all other Federal regulatory requirements.

b. "Specialty Items" shall be construed to be limited to work that requires highly specialized knowledge, abilities, or equipment not ordinarily available in the type of contracting organizations qualified and expected to bid or propose on the contract as a whole and in general are to be limited to minor components of the overall contract.

2. The contract amount upon which the requirements set forth in paragraph (1) of Section VI is computed includes the cost of material and manufactured products which are to be purchased or produced by the contractor under the contract provisions.

3. The contractor shall furnish (a) a competent superintendent or supervisor who is employed by the firm, has full authority to direct performance of the work in accordance with the contract requirements, and is in charge of all construction operations (regardless of who performs the work) and (b) such other of its own organizational resources (supervision, management, and engineering services) as the contracting officer determines is necessary to assure the performance of the contract.

4. No portion of the contract shall be sublet, assigned or otherwise disposed of except with the written consent of the contracting officer, or authorized representative, and such consent when given shall not be construed to relieve the contractor of any responsibility for the fulfillment of the

contract. Written consent will be given only after the contracting agency has assured that each subcontract is evidenced in writing and that it contains all pertinent provisions and requirements of the prime contract.

5. The 30% self-performance requirement of paragraph (1) is not applicable to design-build contracts; however, contracting agencies may establish their own self-performance requirements.

VII. SAFETY: ACCIDENT PREVENTION

This provision is applicable to all Federal-aid construction contracts and to all related subcontracts.

1. In the performance of this contract the contractor shall comply with all applicable Federal, State, and local laws governing safety, health, and sanitation (23 CFR 635). The contractor shall provide all safeguards, safety devices and protective equipment and take any other needed actions as it determines, or as the contracting officer may determine, to be reasonably necessary to protect the life and health of employees on the job and the safety of the public and to protect property in connection with the performance of the work covered by the contract.
2. It is a condition of this contract, and shall be made a condition of each subcontract, which the contractor enters into pursuant to this contract, that the contractor and any subcontractor shall not permit any employee, in performance of the contract, to work in surroundings or under conditions which are unsanitary, hazardous or dangerous to his/her health or safety, as determined under construction safety and health standards (29 CFR 1926) promulgated by the Secretary of Labor, in accordance with Section 107 of the Contract Work Hours and Safety Standards Act (40 U.S.C. 3704).
3. Pursuant to 29 CFR 1926.3, it is a condition of this contract that the Secretary of Labor or authorized representative

thereof, shall have right of entry to any site of contract performance to inspect or investigate the matter of compliance with the construction safety and health standards and to carry out the duties of the Secretary under Section 107 of the Contract Work Hours and Safety Standards Act (40 U.S.C.3704).

VIII. FALSE STATEMENTS CONCERNING HIGHWAY PROJECTS

This provision is applicable to all Federal-aid construction contracts and to all related subcontracts.

In order to assure high quality and durable construction in conformity with approved plans and specifications and a high degree of reliability on statements and representations made by engineers, contractors, suppliers, and workers on Federal-aid highway projects, it is essential that all persons concerned with the project perform their functions as carefully, thoroughly, and honestly as possible. Willful falsification, distortion, or misrepresentation with respect to any facts related to the project is a violation of Federal law. To prevent any misunderstanding regarding the seriousness of these and similar acts, Form FHWA-1022 shall be posted on each Federal-aid highway project (23 CFR 635) in one or more places where it is readily available to all persons concerned with the project:

18 U.S.C. 1020 reads as follows:

"Whoever, being an officer, agent, or employee of the United States, or of any State or Territory, or whoever, whether a person, association, firm, or corporation, knowingly makes any false statement, false representation, or false report as to the character, quality, quantity, or cost of the material used or to be used, or the quantity or quality of the work performed or to be performed, or the cost thereof in connection with the submission of plans, maps, specifications, contracts, or costs of

construction on any highway or related project submitted for approval to the Secretary of Transportation; or

Whoever knowingly makes any false statement, false representation, false report or false claim with respect to the character, quality, quantity, or cost of any work performed or to be performed, or materials furnished or to be furnished, in connection with the construction of any highway or related project approved by the Secretary of Transportation; or

Whoever knowingly makes any false statement or false representation as to material fact in any statement, certificate, or report submitted pursuant to provisions of the Federal-aid Roads Act approved July 1, 1916, (39 Stat. 355), as amended and supplemented;

Shall be fined under this title or imprisoned not more than 5 years or both."

IX. IMPLEMENTATION OF CLEAN AIR ACT AND FEDERAL WATER POLLUTION CONTROL ACT

This provision is applicable to all Federal-aid construction contracts and to all related subcontracts.

By submission of this bid/proposal or the execution of this contract, or subcontract, as appropriate, the bidder, proposer, Federal-aid construction contractor, or subcontractor, as appropriate, will be deemed to have stipulated as follows:

1. That any person who is or will be utilized in the performance of this contract is not prohibited from receiving an award due to a violation of Section 508 of the Clean Water Act or Section 306 of the Clean Air Act.
2. That the contractor agrees to include or cause to be included the requirements of paragraph (1) of this Section X in every subcontract, and further agrees to take such action as the contracting agency may direct as a means of enforcing such requirements.

X. CERTIFICATION REGARDING DEBARMENT, SUSPENSION, INELIGIBILITY AND VOLUNTARY EXCLUSION

This provision is applicable to all Federal-aid construction contracts, design-build contracts, subcontracts, lower-tier subcontracts, purchase orders, lease agreements, consultant contracts or any other covered transaction requiring FHWA approval or that is estimated to cost \$25,000 or more – as defined in 2 CFR Parts 180 and 1200.

1. Instructions for Certification – First Tier Participants:

a. By signing and submitting this proposal, the prospective first tier participant is providing the certification set out below.

b. The inability of a person to provide the certification set out below will not necessarily result in denial of participation in this covered transaction. The prospective first tier participant shall submit an explanation of why it cannot provide the certification set out below. The certification or explanation will be considered in connection with the department or agency's determination whether to enter into this transaction. However, failure of the prospective first tier participant to furnish a certification or an explanation shall disqualify such a person from participation in this transaction.

c. The certification in this clause is a material representation of fact upon which reliance was placed when the contracting agency determined to enter into this transaction. If it is later determined that the prospective participant knowingly rendered an erroneous certification, in addition to other remedies available to the Federal Government, the contracting agency may terminate this transaction for cause of default.

d. The prospective first tier participant shall provide immediate written notice to the contracting agency to whom this proposal is submitted if any time the prospective first tier participant learns that its certification was erroneous when submitted or has become erroneous by reason of changed circumstances.

e. The terms "covered transaction," "debarred," "suspended," "ineligible," "participant," "person," "principal," and "voluntarily excluded," as used in this clause, are defined in 2 CFR Parts 180 and 1200. "First Tier Covered Transactions" refers to any covered transaction between a grantee or subgrantee of Federal funds and a participant (such as the prime or general contract). "Lower Tier Covered Transactions" refers to any covered transaction under a First Tier Covered Transaction (such as subcontracts). "First Tier Participant" refers to the participant who has entered into a covered transaction with a grantee or subgrantee of Federal funds (such as the prime or general contractor). "Lower Tier Participant" refers any participant who has entered into a covered transaction with a First Tier Participant or other Lower Tier Participants (such as subcontractors and suppliers).

f. The prospective first tier participant agrees by submitting this proposal that, should the proposed covered transaction be entered into, it shall not knowingly enter into any lower tier covered transaction with a person who is debarred, suspended, declared ineligible, or voluntarily excluded from participation in this covered transaction, unless authorized by the department or agency entering into this transaction.

g. The prospective first tier participant further agrees by submitting this proposal that it will include the clause titled "Certification Regarding Debarment, Suspension, Ineligibility and Voluntary Exclusion-Lower Tier Covered Transactions," provided by the department or contracting agency, entering into this

covered transaction, without modification, in all lower tier covered transactions and in all solicitations for lower tier covered transactions exceeding the \$25,000 threshold.

h. A participant in a covered transaction may rely upon a certification of a prospective participant in a lower tier covered transaction that is not debarred, suspended, ineligible, or voluntarily excluded from the covered transaction, unless it knows that the certification is erroneous. A participant is responsible for ensuring that its principals are not suspended, debarred, or otherwise ineligible to participate in covered transactions. To verify the eligibility of its principals, as well as the eligibility of any lower tier prospective participants, each participant may, but is not required to, check the Excluded Parties List System website (<https://www.epls.gov/>), which is compiled by the General Services Administration.

i. Nothing contained in the foregoing shall be construed to require the establishment of a system of records in order to render in good faith the certification required by this clause. The knowledge and information of the prospective participant is not required to exceed that which is normally possessed by a prudent person in the ordinary course of business dealings.

j. Except for transactions authorized under paragraph (f) of these instructions, if a participant in a covered transaction knowingly enters into a lower tier covered transaction with a person who is suspended, debarred, ineligible, or voluntarily excluded from participation in this transaction, in addition to other remedies available to the Federal Government, the department or agency may terminate this transaction for cause or default.

* * * * *

2. Certification Regarding Debarment, Suspension, Ineligibility and Voluntary Exclusion – First Tier Participants:

a. The prospective first tier participant certifies to the best of its knowledge and belief, that it and its principals:

(1) Are not presently debarred, suspended, proposed for debarment, declared ineligible, or voluntarily excluded from participating in covered transactions by any Federal department or agency;

(2) Have not within a three-year period preceding this proposal been convicted of or had a civil judgment rendered against them for commission of fraud or a criminal offense in connection with obtaining, attempting to obtain, or performing a public (Federal, State or local) transaction or contract under a public transaction; violation of Federal or State antitrust statutes or commission of embezzlement, theft, forgery, bribery, falsification or destruction of records, making false statements, or receiving stolen property;

(3) Are not presently indicted for or otherwise criminally or civilly charged by a governmental entity (Federal, State or local) with commission of any of the offenses enumerated in paragraph (a)(2) of this certification; and

(4) Have not within a three-year period preceding this application/proposal had one or more public transactions (Federal, State or local) terminated for cause or default.

b. Where the prospective participant is unable to certify to any of the statements in this certification, such prospective participant shall attach an explanation to this proposal.

2. Instructions for Certification - Lower Tier Participants:

(Applicable to all subcontracts, purchase orders and other lower tier transactions requiring prior FHWA approval or estimated to cost \$25,000 or more - 2 CFR Parts 180 and 1200)

a. By signing and submitting this proposal, the prospective lower tier is providing the certification set out below.

b. The certification in this clause is a material representation of fact upon which reliance was placed when this transaction was entered into. If it is later determined that the prospective lower tier participant knowingly rendered an erroneous certification, in addition to other remedies available to the Federal Government, the department, or agency with which this transaction originated may pursue available remedies, including suspension and/or debarment.

c. The prospective lower tier participant shall provide immediate written notice to the person to which this proposal is submitted if at any time the prospective lower tier participant learns that its certification was erroneous by reason of changed circumstances.

d. The terms "covered transaction," "debarred," "suspended," "ineligible," "participant," "person," "principal," and "voluntarily excluded," as used in this clause, are defined in 2 CFR Parts 180 and 1200. You may contact the person to which this proposal is submitted for assistance in obtaining a copy of those regulations. "First Tier Covered Transactions" refers to any covered transaction between a grantee or subgrantee of Federal funds and a participant (such as the prime or general contract). "Lower Tier Covered Transactions" refers to any covered transaction under a First Tier Covered Transaction (such as subcontracts). "First Tier Participant" refers to the participant who has entered into a covered transaction with a grantee or subgrantee of Federal funds (such as the prime or general contractor). "Lower Tier Participant" refers any participant who has entered into a covered transaction with a First Tier Participant or other Lower Tier Participants (such as subcontractors and suppliers).

e. The prospective lower tier participant

agrees by submitting this proposal that, should the proposed covered transaction be entered into, it shall not knowingly enter into any lower tier covered transaction with a person who is debarred, suspended, declared ineligible, or voluntarily excluded from participation in this covered transaction, unless authorized by the department or agency with which this transaction originated.

f. The prospective lower tier participant further agrees by submitting this proposal that it will include this clause titled "Certification Regarding Debarment, Suspension, Ineligibility and Voluntary Exclusion-Lower Tier Covered Transaction," without modification, in all lower tier covered transactions and in all solicitations for lower tier covered transactions exceeding the \$25,000 threshold.

g. A participant in a covered transaction may rely upon a certification of a prospective participant in a lower tier covered transaction that is not debarred, suspended, ineligible, or voluntarily excluded from the covered transaction, unless it knows that the certification is erroneous. A participant is responsible for ensuring that its principals are not suspended, debarred, or otherwise ineligible to participate in covered transactions. To verify the eligibility of its principals, as well as the eligibility of any lower tier prospective participants, each participant may, but is not required to, check the Excluded Parties List System website (<https://www.epls.gov/>), which is compiled by the General Services Administration.

h. Nothing contained in the foregoing shall be construed to require establishment of a system of records in order to render in good faith the certification required by this clause. The knowledge and information of participant is not required to exceed that which is normally possessed by a prudent person in the ordinary course of business dealings.

i. Except for transactions authorized

under paragraph e of these instructions, if a participant in a covered transaction knowingly enters into a lower tier covered transaction with a person who is suspended, debarred, ineligible, or voluntarily excluded from participation in this transaction, in addition to other remedies available to the Federal Government, the department or agency with which this transaction originated may pursue available remedies, including suspension and/or debarment.

* * * * *

Certification Regarding Debarment, Suspension, Ineligibility and Voluntary Exclusion--Lower Tier Participants:

1. The prospective lower tier participant certifies, by submission of this proposal, that neither it nor its principals is presently debarred, suspended, proposed for debarment, declared ineligible, or voluntarily excluded from participating in covered transactions by any Federal department or agency.

2. Where the prospective lower tier participant is unable to certify to any of the statements in this certification, such prospective participant shall attach an explanation to this proposal.

* * * * *

XI. CERTIFICATION REGARDING USE OF CONTRACT FUNDS FOR LOBBYING

This provision is applicable to all Federal-aid construction contracts and to all related subcontracts which exceed \$100,000 (49 CFR 20).

1. The prospective participant certifies, by signing and submitting this bid or proposal, to the best of his or her knowledge and belief, that:

a. No Federal appropriated funds have been paid or will be paid, by or on behalf of the undersigned, to any person for influencing or attempting to influence an

officer or employee of any Federal agency, a Member of Congress, an officer or employee of Congress, or an employee of a Member of Congress in connection with the awarding of any Federal contract, the making of any Federal grant, the making of any Federal loan, the entering into of any cooperative agreement, and the extension, continuation, renewal, amendment, or modification of any Federal contract, grant, loan, or cooperative agreement.

b. If any funds other than Federal appropriated funds have been paid or will be paid to any person for influencing or attempting to influence an officer or employee of any Federal agency, a Member of Congress, an officer or employee of Congress, or an employee of a Member of Congress in connection with this Federal contract, grant, loan, or cooperative agreement, the undersigned shall complete and submit Standard Form-LLL, "Disclosure Form to Report Lobbying," in accordance with its instructions.

2. This certification is a material representation of fact upon which reliance was placed when this transaction was made or entered into. Submission of this certification is a prerequisite for making or entering into this transaction imposed by 31 U.S.C. 1352. Any person who fails to file the required certification shall be subject to a civil penalty of not less than \$10,000 and not more than \$100,000 for each such failure.

3. The prospective participant also agrees by submitting its bid or proposal that the participant shall require that the language of this certification be included in all lower tier subcontracts, which exceed \$100,000 and that all such recipients shall certify and disclose accordingly.

ATTACHMENT A EMPLOYMENT AND MATERIALS PREFERENCE FOR APPALACHIAN DEVELOPMENT HIGHWAY SYSTEM OR APPALACHIAN LOCAL ACCESS ROAD CONTRACTS

This provision is applicable to all Federal-aid projects funded under the Appalachian Regional Development Act of 1965.

1. During the performance of this contract, the contractor undertaking to do work which is, or reasonably may be, done as on-site work, shall give preference to qualified persons who regularly reside in the labor area as designated by the DOL wherein the contract work is situated, or the subregion, or the Appalachian counties of the State wherein the contract work is situated, except:

a. To the extent that qualified persons regularly residing in the area are not available.

b. For the reasonable needs of the contractor to employ supervisory or specially experienced personnel necessary to assure an efficient execution of the contract work.

c. For the obligation of the contractor to offer employment to present or former employees as the result of a lawful collective bargaining contract, provided that the number of nonresident persons employed under this subparagraph (1c) shall not exceed 20 percent of the total number of employees employed by the contractor on the contract work, except as provided in subparagraph (4) below.

2. The contractor shall place a job order with the State Employment Service indicating (a) the classifications of the laborers, mechanics and other employees required to perform the contract work, (b) the number of employees required in each classification, (c) the date on which the participant estimates such employees will be required, and (d) any other pertinent information required by the State

Employment Service to complete the job order form. The job order may be placed with the State Employment Service in writing or by telephone. If during the course of the contract work, the information submitted by the contractor in the original job order is substantially modified, the participant shall promptly notify the State Employment Service.

3. The contractor shall give full consideration to all qualified job applicants referred to him by the State Employment Service. The contractor is not required to grant employment to any job applicants who, in his opinion, are not qualified to perform the classification of work required.

4. If, within one week following the placing of a job order by the contractor with the State Employment Service, the State Employment Service is unable to refer any qualified job applicants to the contractor, or less than the number requested, the State Employment Service will forward a certificate to the contractor indicating the unavailability of applicants. Such certificate shall be made a part of the contractor's permanent project records. Upon receipt of this certificate, the contractor may employ persons who do not normally reside in the labor area to fill positions covered by the certificate, notwithstanding the provisions of subparagraph (1c) above.

5. The provisions of 23 CFR 633.207(e) allow the contracting agency to provide a contractual preference for the use of mineral resource materials native to the Appalachian region.

6. The contractor shall include the provisions of Sections 1 through 4 of this Attachment A in every subcontract for work which is, or reasonably may be, done as on-site work.

REFERENCE SHEET

All bidders are required to complete this form providing three references of past performance. References should involve projects and/or service situations of similar size, scope, and character of work to this Bid. References must have had dealings with the Bidder within the last thirty-six (36) months. The County reserves the right to contact any or all of the references supplied for an evaluation of past performance in order to establish the responsibility of the Bidder before the actual award of the Bid and/or Contract. Completion of the Reference Form is required.

BIDDER'S NAME: _____

DATE FILED: _____

REFERENCE'S NAME: _____

ADDRESS: _____

TELEPHONE: _____ CONTACT PERSON: _____

REFERENCE'S NAME: _____

ADDRESS: _____

TELEPHONE: _____ CONTACT PERSON: _____

REFERENCE'S NAME: _____

ADDRESS: _____

TELEPHONE: _____ CONTACT PERSON: _____

LOCAL LAW NUMBER 12- 2012 AMENDED BY LOCAL LAW NUMBER 5- 2015 COUNTY OF CATTARAUGUS, NEW YORK

Pursuant to Section 10 of the Municipal Home Rule Law and Section 103 of the General Municipal Law.

A LOCAL LAW ESTABLISHING UNIFORM GUIDELINES FOR DETERMINING THE RESPONSIBILITY OF BIDDERS

BE IT ENACTED by the Legislature of the County of Cattaraugus ("the County"), as follows:

Section 1. Legislative Intent. It is the intent of this Local Law to enhance the County's ability to identify the lowest "responsible bidder" on public works construction projects by instituting more comprehensive submission requirements and an evaluation system which is in compliance with New York State General Municipal Law. The County, based upon its experience, has determined that quality workmanship, efficient operation, safety, and timely completion of projects are not necessarily assured by awarding a public works contract solely on the basis of the low price. This Local Law establishing uniformity of guidelines for determining the responsibility of apparent low bidders will assure efficient use of taxpayer dollars, will promote public safety, and is in the public interest.

Section 2. Applicability. This Local Law shall apply to construction projects subject to the competitive bidding requirements of General Municipal Law §103 and advertised for bids on or after the effective date.

Section 3. Public Works. For purposes of this Local Law, the term "public works" shall mean the following: any constructing, altering, reconstructing, repairing, rehabilitating, refinishing, refurbishing, remodeling, remediating, renovating, custom fabricating, maintenance, landscaping, improving, moving, wrecking, painting, decorating, demolishing, and adding to or subtracting from any public building, structure, highway, roadway, street, alley, bridge, sewer, drain, ditch, sewage disposal plant, water work, parking facility, railroad, excavation, or other project, development, real property, or improvement, or to any part thereof, whether or not the performance of the work herein described involves the addition to, or fabrication into, any structure, project or development, real property or improvement herein described of any material or article of merchandise, which is paid for out of public funds in an amount exceeding the threshold for bidding established by the General Municipal Law. The term also includes any public works leased by the County under a lease containing an option to purchase exceeding the threshold for bidding public works projects established by the General Municipal Law.

Section 4. Cattaraugus County Vendor Responsibility Form and Procedure.

- A. A questionnaire (which shall be titled the "Cattaraugus County Vendor Responsibility Form"), hereinafter "the Form", shall be prepared and, as he/she may deem appropriate, revised by the Cattaraugus County Commissioner of Public Works ("Commissioner").
- B. The Commissioner shall provide the Form to the apparent low bidder on all County public works projects.
- C. The County shall promptly notify the apparent low bidder of its status as such and provide such entity with a copy of the Form either in electronic or paper format. The most current version of the Form shall also be posted on the Cattaraugus County website.

- D. The apparent low bidder shall file the Form in in the Office of the Commissioner not more than five (5) business days after receiving it or, if the form is mailed to the apparent low bidder, within ten (10) business days after the date of mailing.
- E. In the event that the apparent low bidder fails to file the fully completed Form in the Commissioner's Office within the required time, its bid will be rejected and any bid bond submitted may, at the County's sole discretion, be forfeited.
- F. If the apparent low bidder is deemed not responsible, or fails to submit the Form within the required time, then the next lowest bidder will be deemed the apparent low bidder and so on until the lowest bidder is deemed responsible and selected as the lowest responsible bidder.
- G. Not later than five (5) calendar days prior to a final determination that the apparent low bidder is not responsible, the County will notify the bidder of same, in writing, and by certified mail, return receipt, stating the reasons. Except in the case of the rejection of an apparent low bid solely because the vendor failed to timely submit a completed Form, such notice shall set forth a time, date and place for the apparent low bidder to appear and be heard, not less than five (5) business days after such notice is served.
- H. Subcontractors proposed to be used on a project must also complete and submit the Form within five (5) days after the preconstruction meeting before the subcontractor is approved by the County. Failure by a subcontractor to submit the Form or unsatisfactory responses to questions may lead to rejection of the bid of the subcontractor at the County's discretion.
- I. If the bid of the apparent low bidder appears disproportionately low when compared with estimates obtained by or on behalf of the County and/or compared to other bids submitted (10% or greater disparity), the County reserves the right to inquire further of the apparent low bidder to determine whether the bid contains mathematical errors, omissions and/or erroneous assumptions, and whether the apparent low bidder has the capability to perform and complete the contract for the bid amount.
- J. If a bidder is found to have willfully violated New York Labor Law §220 within the previous five (5) years, that bidder shall automatically be deemed "not responsible" and its bid shall be rejected unless the Commissioner, subject to review by the Public Works Committee of the Cattaraugus County Legislature, determines otherwise. In all other cases, based on all of the information collected pursuant to this local law and any other factor deemed relevant, the Commissioner, or other department heads soliciting public works bids, shall determine if the apparent lowest bidder is in fact "responsible."

Section 5. Additional Requirements.

- A. Contractors and all subcontractors shall classify their workers as employees rather than as independent contractors, unless those workers meet the definition of "independent contractor" as defined by the Internal Revenue Service, and shall treat said employees accordingly for purposes of workers' compensation insurance coverage, unemployment insurance, employment taxes, and social security taxes.
- B. The contractors and all subcontractors shall submit certified payrolls to the Commissioner.

Section 6. Procedure. Cattaraugus County will make its own determinations of responsibility for low bidders. A bidder recognized by the state as a responsible vendor must still satisfy the requirements of this local law by submitting the required Cattaraugus County Vendor Responsibility Form within the required time frame.

Section 7. Incomplete Submissions by Bidders and Subcontractors. It is the sole responsibility of the contractor to comply with all submission requirements to the County. The submission requirements also apply to all subcontractors, except that the contractor shall submit all subcontractor questionnaires to the County of Cattaraugus for approval. Failure to submit the Form may lead to the rejection of the bid of the subcontractor at the County's discretion. Contractor submissions deemed non-responsive will result in automatic rejection of the bid.

Section 8. Materiality. The requirements of this Local Law are a material part of the bid documents and the contract and the successful bidder shall insert this Local Law in all subcontracts.

Section 9. Severability. If any clause, sentence, paragraph, subdivision, section or part of this Local law or the application thereof, to any person, individual, corporation, firm, partnership, entity or circumstance, shall be adjudged by any court of competent jurisdiction to be invalid or unconstitutional such order of Judgment shall not affect, impair, or invalidate the remainder thereof, but shall be confined in its operation to the clause, sentence, paragraph, subdivision, section or part of this Local law or in its application to the person, individual, corporation, firm, partnership, entity, or circumstance directly involved In the controversy in which such judgment or order shall be rendered.

Section 10. Other Local Laws. Any prior Local Law or portion thereof in conflict with this Local Law is hereby repealed.

Section 11. Effective Date. This Local Law shall take effect upon filing in the Office of the Secretary of State, in accordance with Section 27 of the New York State Municipal Home Rule Law.

Iran Divestment Act of 2012”“Iranian Energy Sector Divestment”

Pursuant to State Finance Law § 165-a, the Commissioner of General Services is required to develop a list of persons it determines engage in investment activities in Iran, which is defined as provision of goods, services or credit of \$20,000,000 or more, relating to the energy sector.

General Municipal Law § 103-g(4) states as follows:

Every bid or proposal hereafter made to a political subdivision of the state or any public department, agency or official thereof where competitive bidding is required by statute, rule, regulation or local law, for work or service performed or to be performed or good sold or to be sold, shall contain the following statement subscribed by the bidder and affirmed by such bidder as true under penalties of perjury:

The below signed bidder affirms the following as true under penalties of perjury:

- a. “By submission of this bid, the bidder identified herein and each person signing on behalf of the bidder certifies, and in the case of a joint bid each party thereto certifies as to its own organization, under penalty of perjury, that to the best of its knowledge and belief that this bidder is not on the list created pursuant to paragraph (b) of subdivision 3 of Section 165-a of the state finance law.”

Corporate or Company Name

By: _____
Signature

Title

Sworn to before me this

_____ Day of _____, 20_____

Notary Public

CATTARAUGUS COUNTY

DEPARTMENT OF PUBLIC WORKS

Development – Progress – Workmanship

Kathleen M. Ellis, Commissioner
Devin M. Blue, Deputy Commissioner
Mark C. Burr, PE, Director of Engineering



8810 Route 242, Jack Ellis Drive
Little Valley, New York 14755
Phone (716) 938 9121 | Fax (716) 938 2754

PROJECT TITLE: 2020 Bridge Painting Program

AFFIDAVIT OF COMPLIANCE AND RECEIPT OF PREVAILING WAGE SCHEDULE

The Contractor named below certifies receipt of Prevailing Wage Rate Schedule and is in compliance with all labor laws and regulations of the State of New York and the United States of America including the following:

1) PREVAILING WAGE RATE:

The contractor agrees to comply with the schedule of wages applicable to the performance of the said contract and the statutory requirements and rules of the State of New York. The Contractor named below certifies that they have received the Prevailing Wage Rate Schedule **PRC# 2019014891**.

2) SOCIAL SECURITY TAXES:

The contractor promises and agrees to pay the taxes measured by the wages of their employees required by the Federal Social Security Act and all amendments thereto, and to accept the exclusive liability for said taxes.

Company

Print Name Title

Signature Date

State of New York)
) ss:
County of _____)

Subscribed and Sworn to before me this _____ day of _____ 20 ____

By _____

Notary Public, _____

AGREEMENT

This AGREEMENT made as of the _____ day of _____ in the year 20__ by and between the County of Cattaraugus, a municipal corporation hereinafter called the “County” and _____ hereinafter called the “Contractor”.

WITNESSETH that the County and Contractor in consideration of the mutual covenants hereinafter set forth, agree as follows:

Article 1. WORK. The Contractor will perform all Work as shown in the Contract Documents for the completion of the Project generally described as the 2020 Bridge Painting Program, Cattaraugus County, New York.

(a) The Contractor shall furnish all of the materials and do all the Work required for 2020 Bridge Painting Program and all other incidental work detailed in the contract documents.

<u>Location/BIN Number</u>	<u>To Be Included in This Contract</u>	<u>Not to Be Included in This Contract</u>
Freedom Bridge No 1, BIN 3321510, CR21- Delevan-Elton Road over South Branch Elton Creek	_____	_____
East Otto Bridge No 27, BIN 3321150, Hammond Hill Road over Connoisarauley Creek	_____	_____
South Valley Bridge No 04, BIN 3323210 County Road 33 over Bone Run	_____	_____

Article 2. ENGINEER. The Project has been designed by Greenman-Pedersen, Inc. and is hereinafter called the ENGINEER. The County and the ENGINEER will provide all on-site observation services, and County observation personnel will also be referred to as the ENGINEER.

Article 3. CONTRACT TIME. Time of beginning rate of progress and time of completion are essential conditions of the Contract. The Contractor shall commence work within ten (10) days of the effective date of the Contract, unless written consent is given by the County to begin at a later date. All work shall be completed by October 31, 2020.

Article 4. CONTRACT PRICE. The County shall pay the Contractor for the performance of the Work in accordance with the Itemized Bid indicated in the bid documents.

Article 5. PAYMENTS. The County shall make payments on the account of the Contract as follows:

(a) Upon request from the Contractor, the Engineer and the County will review and approve statements prepared by the Contractor for the total quantity of work properly

AGREEMENT

completed by the Contractor as of a specified date noted on the statement. No such statement, however, will be reviewed by the Engineer and County within one month after the start of Work under contract, or at intervals of less than one month. The County will pay the Contractor of the amount of each statement, less prior payments, forty-five (45) days after approval of the statement. Neither statement nor payment shall mean that any Work is accepted. The statements should be based on the percent complete of each subtask noted in the Itemized schedule.

- (b) The acceptance by the Contractor of the final payment of amounts withheld from the Engineer's statements shall be and shall operate as a release to the County and the Engineer of all claims and of all liability to the Contractor for all things done or furnished in connection with this Work and for every act and neglect of the County and Engineer and others relating to or arising out of this Work.
- (c) The County reserves the right, at any time, to modify or change the Plans or Specifications as deemed necessary, and the Agreement shall not be invalidated thereby, however.
- (d) If the Contractor considers that he is being required to perform extra work for which no Change Order has been issued, then he shall serve Written Notice upon the County prior to such extra work is performed. On failure to serve this Notice, all rights of the Contractor to be paid therefore shall be forfeited.
- (e) As the work progresses in accordance with the contract and in a manner that is satisfactory to the County, the County hereby agrees to make payments to the Contractor therefore, based upon the proposal attached hereto and made part thereof as follows: The County shall once in each month and on such days as it may fix, determine the quantity of work completed and of material which has actually been put in place in accordance with the terms and conditions of the contract, during the preceding month, and compute the value thereof and pay to the Contractor the monies due as provided in §106-b of the General Municipal Law. No monthly payments shall be rendered unless the value of the work completed equals 10% of the contract amount or \$1,000 whichever is the lesser. Semimonthly payments may be rendered provided (a) the value of the work performed in two successive weeks is more than \$50,000 or (b) the Commissioner of Public Works deems it to be in the best interests of the County to do so. The Contractor shall not hold any retainage from any Subcontractor.

Article 6. CONTRACT DOCUMENTS. The Contract Documents which comprise the Contract between the Owner and the Contractor are attached hereto and made a part hereof and consist of the following:

- (a) The General Provisions and Proposal Booklet titled "2020 Bridge Painting Program" and dated January 2020.
- (b) Drawings and Plans
- (c) Any Modifications, including Addenda, duly delivered before the execution of this Agreement, and Change Orders incorporated after the Agreement is signed.

AGREEMENT

- (d) Bonds and Insurance instruments.

Article 7. MISCELLANEOUS.

- (a) Terms used in this Agreement shall have the same meanings which are defined in Section 101 of the NYSDOT Standard Specification, Construction and Materials of January 1, 2020 and all Addenda.
- (b) The Contractor shall furnish a faithful performance surety bond on a form approved by the County in an amount equal to 100 percent of the Contract Price, and shall have as a surety thereon a surety company or companies authorized to do business in New York State. He likewise will furnish a Labor and Material Bond to guarantee the payment of all Labor and Materials supplied in connection with this Agreement.
- (c) Neither the County nor the Contractor shall, without the prior written consent of the other, assign or sublet in whole or in part his interest under any of the Contract Documents and, specifically, the Contractor shall not assign any monies due or to become due without the prior written consent of the County.
- (d) The County and the Contractor each binds himself, his partners, successors, assigns and legal representatives to the other party hereto in respect of all covenants, agreements and obligations contained in the Contract Documents.
- (e) The Contract Documents constitute the entire agreement between the County and the Contractor and may only be altered, amended or repealed by a duly executed written instrument.

Article 8. CONTRACTOR REPRESENTATIONS. The Contractor is experienced in the use and interpretation of plans and specifications such as those included in these Contract Documents. He has carefully reviewed these and all of the Contract Documents and has found them free of ambiguity and sufficient for bid purposes. He has based his bid solely on these documents not relying on any explanation or interpretation, oral or written, from any other source.

Article 9. CONTRACT PROVISIONS. The parties to the attached contract, license, lease, amendment or other agreement of any kind (hereinafter, "the contract" or "this contract") agree to be bound by the following clauses which are hereby made a part of the contract (the word "Contractor" herein refers to any part other than the County of Cattaraugus or Greenman-Pedersen, Inc., whether a contractor, licensor, licensee, lessor, lessee or any other party). In the event of a conflict between the terms of the contract (including any and all amendments thereto and amendments thereof) and the terms of this Article, the terms of this Article shall control.

- (a) Non-Assignment Clause

In accordance with Section 109 of the General Municipal Law, this contract may not be assigned by the Contractor, or its right, title or interest therein assigned, transferred, conveyed, sublet or otherwise disposed of without the previous consent, in writing, of the County and any attempts to assign the contract without the County's written consent are null and void.

AGREEMENT

(b) Workers' Compensation Benefits

In accordance with Section 108 of the General Municipal Law, this contract shall be void and of no force and effect unless the Contractor shall provide and maintain coverage during the life of this contract for the benefit of such employees as are required to be covered by the provisions of the Workers' Compensation Law.

(c) Non-Discrimination Requirements

In accordance with Article 15 of the Executive Law (also known as the Human Rights Law) and all other State and Federal statutory and constitutional non-discrimination provisions, the Contract will not discriminate against any employee or applicant for employment because of race, creed, color, sex, national origin, age, disability or marital status. Furthermore, in accordance with Section 220-e of the Labor Law, if this is a contract for the construction, alteration or repair of any public building or public work or for the manufacture, sale or distribution of materials, equipment or supplies, and to the extent that this contract shall be performed within the State of New York, Contractor agrees that neither it nor its subcontractors shall, by reason of race, creed, color, disability, sex or national origin: (a) discriminate in hiring against any New York State citizen who is qualified and available to perform the work; or (b) discriminate against or intimidate any employee hired for the performance of work under this contract. If this is a building service contract as defined in Section 230 of the Labor Law, then, in accordance with Section 239 thereof, Contractor agrees that neither it nor its subcontractors shall, by reason of race, creed, color, national origin, age, sex or disability (a) discriminate in hiring against any New York State citizen who is qualified and available to perform the work; or (b) discriminate against or intimidate any employee hired for the performance of work under this contract. Contractor is subject to fines of \$50.00 per person per day for any violation of Section 220-e or Section 239 as well as possible termination of this contract and forfeiture of all monies due hereunder for a second or subsequent violation.

(d) Wage and Hours Provisions

If this is a public work contract covered by Article 8 of the Labor Law or a building service contract covered by Article 9 thereof, neither Contractor's employees nor the employees of its subcontractors may be required or permitted to work more than the number of hours or days stated in such statute, except as otherwise provided in the Labor Law and as set forth in prevailing wage and supplement schedules issued by the State Labor Department. Furthermore, Contractor and its subcontractors must pay at least the prevailing wage rate and pay or provide the prevailing supplements, including the premium rates for overtime pay, as determined by the State Labor Department in accordance with the Labor Law.

(e) Non-Collusive Bidding Requirement

In accordance with Section 103-d of the General Municipal Law, if this contract was awarded based upon the submission of bids, Contractor warrants, under penalty of perjury, that its bid was arrived at independently and without collusion aimed at

AGREEMENT

restricting competition. Contractor further warrants that, at the time Contractor submitted its bid, an authorized and responsible person executed and delivered to the County a non-collusive bidding certification on the Contractor's behalf.

(f) Set-Off Rights

The County shall have all of its common law and statutory rights of set-off. These rights shall include, but not be limited to, the County's option to withhold for the purposes of set-off any monies due to the Contractor under this contract up to any amounts due and owing to the County with regard to this contract.

(g) Record-Keeping Requirement

The Contractor shall establish and maintain complete and accurate books, records, documents, accounts and other evidence directly pertinent to performance under this contract for a period of six (6) years following final payment or the termination of this contract, whichever is later, and any extensions thereto. The County Treasurer or County Administrator or any other person or entity authorized to conduct an examination, as well as the agency or agencies involved in this contract, shall have access to such books, records, documents, accounts and other evidential material during the contract term, extensions thereof and such (6) year period thereafter for the purposes of inspection, auditing and copying. "Termination of this contract", shall mean the later of completion of the work of the contract or the end date of the term stated in the contract.

(h) Governing Law

This contract shall be governed by the laws of the State of New York, except where the Federal supremacy clause requires otherwise.

(i) No Arbitration and Service of Process

Disputes involving this contract, including the breach or alleged breach thereof, may not be submitted to binding arbitration (except where statutorily authorized) but must, instead, be heard in a court of competent jurisdiction of the State of New York. Contractor hereby consents to service of process upon it by registered or certified mail, return receipt requested.

(j) Approval by County Legislature

This contract is subject to, and conditioned upon, approval by the Cattaraugus County Legislature.

(k) Postponement, Suspension, Abandonment or Termination of Contract

The County shall have the right to postpone, suspend, abandon or terminate this contract, and such actions shall in no event be deemed a breach of contract. In the event of any termination, postponement, delay, suspension or abandonment, the Contractor shall deliver to the County all data, reports, plans, or other documentation

AGREEMENT

related to the performance of this contract, including but not limited to guarantees, warranties, as-built plans and shop drawings. In any of these events, the County shall make settlement with the Contractor upon an equitable basis as determined by the County which shall fix the value of the work which was performed by the Contractor prior to the postponement, suspension, abandonment or termination of this contract. This clause shall not apply to this contract if the contract contains other provisions applicable to postponement, suspension or termination of the contract.

(l) Indemnification

The Contractor shall indemnify and save harmless Cattaraugus County, its officers, and employees, the Engineer and Greenman-Pedersen, Inc., from all suits, actions, or claims of any character brought because of any injuries or damage received or sustained by any person, persons, or property on account of the operations of such Contractor; or on account of or in consequence of any neglect in safeguarding the work; or through use of unacceptable materials in constructing the work; or because of any act of omission, neglect, or misconduct of the Contractor; or because of any claims or amounts recovered from any infringements of patent, trademark, or copyright; or from any claims on amounts arising or recovered under the Workers Compensation Law, or any other law, ordinance, order, or decree; and so much of the money due the Contractor under and by virtue of his Contract as shall be considered necessary by the County for such purpose, may be retained for the use of the County; or, in case no money is due, his surety may be held until such suit or suits, action or actions, claim or claims for injuries or damages as aforesaid shall have been settled and suitable evidence to that effect furnished to the County; except that money due the Contractor will not be withheld when the Contractor produces satisfactory evidence that he is adequately protected by public liability and property damage insurance.

The Contractor agrees to make no claim for damages for delay in the performance of this contract occasioned by any act or omission to act of the County, the Engineer, or Greenman-Pedersen, Inc. or any of its representatives, and the Contractor agrees that any such claim shall be fully compensated for by an extension of time to complete the performance of work as provided herein. This indemnification shall include all costs and disbursements incurred by the County, the Engineer and Greenman-Pedersen, Inc. in defending any suit, including attorney's fees.

(m) Conflict of Interest

- (1) The Contractor warrants that to the best of the Contractor's knowledge and belief, there are no relevant facts or circumstances which could give rise to an organizational conflict of interest, as herein defined, or that the Contractor has disclosed all such relevant information to the County.
- (2) An organizational conflict of interest exists when the nature of the work to be performed under this contract may, without some restriction on future activities, either result in an unfair competitive advantage to the Contractor or impair the Contractor's objectivity in performing the work for the County.

AGREEMENT

- (3) The Contractor agrees that if an actual or potential organizational conflict of interest is discovered after award, the Contractor will make a full disclosure in writing to the County. This disclosure shall include a description of actions which the Contractor has taken or proposes to take, after consultation with the County, to avoid, mitigate, or minimize the actual or potential conflict.
- (4) The County may terminate this contract in whole or in part, if it deems such termination necessary to avoid an organizational conflict of interest. If the Contractor was aware of a potential organizational conflict of interest prior to award, or discovered an actual or potential conflict after award and did not disclose or misrepresented relevant information to the County, then the County may terminate the contract, or pursue such other remedies as may be permitted by law or this contract. The terms of Clause (k) of this Section or other applicable contract provision regarding termination shall apply to termination by the County pursuant to this clause.
- (5) The Contractor further agrees to insert in any subcontract hereunder, provisions which shall conform to the language of this clause.

(n) Requests for Payment

All requests for payment by the Contractor must be submitted on forms supplied and approved by the County. Each payment request must contain such items of information and supporting documentation as required by the County, and shall be all inclusive for the period of time covered by the payment request.

(o) Performance of Work Required

The Contractor agrees that during the performance of the work required pursuant to this Agreement, the Contractor and all officers, employees, agents or representatives working under the Contractor's direction shall strictly comply with all local, state or federal laws, ordinances, rules or regulations controlling or limiting in any way the performance of the work required by this Agreement. Furthermore, each and every provision of law required to be inserted in this Agreement shall be deemed so inserted, and the Agreement shall be read and enforced as if such provisions were so inserted.

The Contractor further agrees to insert in any subcontract hereunder, provisions which shall conform substantially to the language of this clause, including this paragraph.

(p) Independent Contractor Status

It is understood that the Contractor is an independent Contractor and shall not be considered an agent of the County nor shall any of the Contractor's employees or agents be considered sub-agents for the County. The final contract will be between the County and the Contractor and is not intended and shall not be construed to create the relationship of agent, servant, employee, partnership, joint venture, or association between County and Contractor. The employees and agents of one party are not the

AGREEMENT

employees or agents of the other party for any purpose whatsoever. The Contractor understands and agrees that all persons performing work pursuant to the final contract are for purposes of workers' compensation liability, solely employees of the Contractor and not employees of the County. The Contractor shall be solely liable and responsible for furnishing any and all workers' compensation benefits to any person as a result of any injuries arising from or connected with any work performed by or on behalf of the Contractor hereunder. The employees and agents of each party shall while on the premises of the other party, comply with all rules and regulations of the premises including, but not limited to security requirements. The Contractor agrees to comply with the non-discrimination employment policies as required by applicable state and federal laws and regulations regarding employment discrimination. The Contractor assures the County that in accordance with applicable law it does not, and agrees that it will not, discriminate in any manner on the basis of age, color, creed, national origin, race, religious belief, sexual preference, or handicap.

(q) No-Waiver

In the event that the terms and conditions of the Agreement are not strictly enforced by the County, such non-enforcement shall not act as or be deemed to act as a waiver or modification of this Agreement, nor shall such non-enforcement prevent the County from enforcing each and every term of this Agreement thereafter.

(r) Severability

If any provision of this Agreement is held invalid by a court of law, the remainder of this Agreement shall not be affected thereby if such remainder would then continue to conform to the laws of the State of New York.

IN WITNESS WHEREOF, the parties hereto have executed this AGREEMENT the day and year first above written.

Attest

By:

County

Attest

By:

Contractor

AGREEMENT

ACKNOWLEDGMENT OF COUNTY

STATE OF NEW YORK)SS
COUNTY OF CATTARAUGUS)

On this ___ day of _____ 20____, before me, the undersigned, a Notary Public in and for said State, personally appeared _____, personally known to me or proved to me on the basis of satisfactory evidence to be the individual whose name is subscribed to the within instrument and acknowledged to me that he executed the same in his capacity, and that by his signature on the instrument, the individual, or the person upon behalf of which the individual acted, executed the instrument.

Notary Public

ACKNOWLEDGMENT OF CONTRACTOR (OUTSIDE NEW YORK STATE)

STATE OF _____)SS:
COUNTY OF _____)

On this _____ day of _____ 20____, before me, the undersigned, a Notary Public in and for said State, personally appeared _____, personally known to me or proved to me on the basis of satisfactory evidence to be the individual(s) whose name(s) is subscribed to the within instrument and acknowledged to me that he/she/they executed the same in his/her/their capacity(ies), and that by his/her/their signature(s) on the instrument, the individual(s), or the person upon behalf of which the individual(s) acted, executed the instrument and that such individual made such appearance before the undersigned in the City/Town of _____ in State of _____.

(SEAL) _____
Notary Public

AGREEMENT

ACKNOWLEDGMENT OF CONTRACTOR (WITHIN NEW YORK STATE)

STATE OF NEW YORK)SS:
COUNTY OF _____)

On this ____ day of _____ 20____, before me, the undersigned, a Notary Public in and for said State, personally appeared _____, personally known to me or proved to me on the basis of satisfactory evidence to be the individual(s) whose name(s) is subscribed to the within instrument and acknowledged to me that he/she/they executed the same in his/her/their capacity(ies), and that by his/her/their signature(s) on the instrument, the individual(s), or the person upon behalf of which the individual(s) acted, executed the instrument.

(SEAL)
Notary Public

SECTION D

DEFINITIONS AND TERMS

Same as Section 101 of the New York State Department of Transportation Standard Specifications, Construction and Materials of January 1, 2020 and all addenda.

References to the County's representative engineer and County personnel shall hereinafter be made as the "Engineer".

Under this contract the New York State Department of Transportation, Office of Engineering, January 1, 2020 Standard Specifications, Construction and Materials and addenda are amended as follows:

Under Section 101 – Abbreviations and Definitions of Terms

1. Subsection 101-02, Chief Engineer
Delete the stated definition. This term where used in the specifications or contract documents shall mean the "Cattaraugus County Commissioner of Public Works" or his authorized representative.
2. Subsection 101-02, Commissioner
Delete the stated definition. This term where used in the specifications or contract documents shall mean the "Cattaraugus County Commissioner of Public Works".
3. Subsection 101-02, Department
Delete the stated definition. This term where used in the specifications or contract documents shall mean the "Cattaraugus County Department of Public Works" and may also be used to mean the "Commissioner of Public Works" or his authorized representative.
4. Subsection 101-02, Departmental Geotechnical Engineer
Delete the stated definition. The "Cattaraugus County Commissioner of Public Works" or his authorized representative shall be responsible and is in charge of all engineering and construction work on this contract.
5. Subsection 101-02, Departmental Engineering Geologist
Delete the stated definition and substitute the same definition as above for Departmental Geotechnical Engineer.
6. Subsection 101-02, Department
Delete the stated definition and insert: "Cattaraugus County Department of Public Works".
7. Subsection 101-02, Engineer or Engineer-In-Charge
Delete the words "Department of Transportation" and substitute "Cattaraugus County Department of Public Works". Also delete the words "Regional Director" and substitute "Cattaraugus County Commissioner of Public Works".
8. Subsection 101-02, Final Agreement
Delete "State of New York, Department of Transportation" and substitute "Cattaraugus County Department of Public Works".

9. Subsection 101-02, Inspector
Delete “The Department of Transportation” and substitute “The authorized representative of the Cattaraugus County Department of Public Works”.
10. Subsection 101-02, Materials Bureau
Delete the word “Bureau” and the stated definition and substitute “The Cattaraugus County Department of Public Works has the responsibility in the quality assurance for materials to be used on the contract”.
11. Subsection 101-02, Regional Director
Delete the stated definition and substitute: “When used, means the Cattaraugus County Commissioner of Public Works”.
12. Subsection 101-02, State
Delete the stated definition and substitute: “When used, means the County of Cattaraugus, represented by the Cattaraugus County Department of Public Works through the Commissioner of Public Works”.

Under Section 102 – Bidding Requirements and Conditions

13. Subsection 102-01, Location of Regional Offices
Delete the entire subsection – not applicable.
14. Subsection 102-06, Bid Deposit
Delete from the second and third lines the words “State of New York”, and substitute “County of Cattaraugus”.

SECTION E

GENERAL PROVISIONS

The provisions of Section 100 of the New York State Department of Transportation, Office of Engineering Standard Specifications, Construction and Materials of January 1, 2020 and all addenda shall apply except for the following revisions and/or additions included in Section E.

TABLE OF CONTENTS

PART 1 – BIDDING REQUIREMENTS AND CONDITIONS	
1.1	Notice to Bidders (Advertisement)
1.2	Cattaraugus County Vendor Responsibility Form
1.3	Proposal Guaranty
1.4	Delivery of Proposals
1.5	Notice of Special Conditions
1.6	Disqualification of Bidders
1.7	Rejection of Bids
PART 2 – AWARD AND EXECUTION OF CONTRACT	
2.1	Consideration of Proposals
2.2	Cancellation of Award
2.3	Return of Proposal Guaranty
2.4	Bonds
2.5	Failure to Execute Contract
PART 3 – SCOPE OF WORK	
3.1	Responsibility of the Contractor
3.2	One-Call Notification Training Certification
PART 4 – CONTROL OF WORK	
4.1	Authority of Engineer
4.2	Substantial Completion and Final Acceptance of Work
4.3	Contractor’s Personnel
4.4	Cooperation with Utilities
PART 5 – CONTROL OF MATERIALS	
5.1	Certificate of Acceptability
PART 6 – LEGAL RELATIONS AND RESPONSIBILITY TO THE PUBLIC	
6.1	Subcontractors, Materialmen and Laborers
6.2	Responsibility for Damage Claims
6.3	No Waiver of Legal Rights
6.4	Insurance
6.5	Litigation
PART 7 – PROSECUTION AND PROGRESS	
7.1	Notice to Proceed
7.2	Prosecution of Work
7.3	Temporary Suspension of Work
7.4	Date of Completion of Contract Work
7.5	Termination of Contract
7.6	Failure to Complete Work on Time
7.7	Assignment
PART 8 – MEASUREMENT AND PAYMENT	
8.1	Payments on Contract
8.2	Differing Site Conditions

PART 1 BIDDING REQUIREMENTS AND CONDITIONS

1.1 NOTICE TO BIDDERS (ADVERTISEMENT)

Sealed bids for the **2020 Bridge Painting Program**, Cattaraugus County, New York, will be received under the direction of the County Administrator at the Cattaraugus County Department of Public Works Facility, 8810 Route 242, Little Valley, New York until Wednesday **March 25, 2020 at 1:45 p.m.**, after which they will be publicly opened at **2:00 p.m. (at the same location)**, under the direction of the Public Works Committee of the Cattaraugus County Legislature. Each bid, at the time received, will be stamped by a clock showing date and time of receipt.

The Contractor shall furnish all materials, equipment, tools and labor of every kind required for existing paint removal; cleaning, priming, and painting of steel; treatment and disposal of waste material; maintenance and protection of traffic; and all other incidental work in the most substantial and workmanlike manner, and do everything required by the Contract Documents as defined herein.

Copies of the Contract Plans and Documents may be examined at no expense at the following location:

Cattaraugus County Department of Public Works
8810 Route 242
Little Valley, New York 14755
(716) 938-9121

Southern Tier Builders Association
65 West Main Street
Falconer, New York 14733
(716) 665-4026

Copies of the Contract Plans and Documents may be obtained by contacting Dawn Smith at (716) 938-9121 Ext 2465. All documents are in an electronic format.

Questions regarding the contract documents for this project may be directed to William Fox, PE, Sr Civil Engineer for Cattaraugus County DPW, (716) 938-9121.

All bids must be written in ink on the forms provided. The bid must be accompanied by a certified check, cashier's check, or bid bond made payable to "Treasurer, Cattaraugus County", in the amount of 5% of the bid, as a guarantee that if the Contract is awarded to the bidder, he will sign the Contract and furnish a satisfactory performance bond. If a bidder should fail to sign the Contract and deliver the performance bond within ten (10) calendar days after he has received the Contract, then he shall forfeit the bid guarantee.

The Construction of this project will be done in strict accordance with the State of New York Department of Transportation policies, procedures and specifications entitled Standard Specifications, Construction and Materials adopted May 1, 2019 and addenda. The General Provisions of Contract, Contract Forms of Proposal, Agreement, Bonds, General Construction Specifications, Materials of Construction which are contained in the specifications will be adhered to in all respects.

Attention should be paid to Section 106-11 of the New York State Department of Transportation Standard Specifications, Construction and Materials as pertains to Buy America Bid Requirements.

Particular attention is hereby direction to the sections, "Definitions and Terms" and "General Provisions" contained herein which denotes definitions of the responsible parties and/or persons who

will direct and supervise this work and contract in lieu of the references made in the specifications to State Engineer and officials.

In compliance with the provisions of Section 115 (Prevailing Rate of Wage), Public Law 627, the minimum wages paid laborers and mechanics are included in wage schedules that are set out in the bid proposal.

The County of Cattaraugus reserves the right to reject any or all bids, to waive any informality in any bids, and to award the Contract in the County's best interest. The County reserves the right to make the award within forty-five (45) calendar days after the date of the bid opening during which period bids shall not be withdrawn.

1.2 CATTARAUGUS COUNTY VENDOR RESPONSIBILITY FORM

Cattaraugus County Local Law 12-2012 as amended by Local Law 5-2015 requires that the County provide a copy of the Cattaraugus County Vendor Responsibility Form to the low bidder. The low bidder will have 5 business days to return the completed form unless the form was mailed by the county to the vendor, in which case will have 10 business days from the date of the mailing to return the form. Failure by the low bidder to submit the form within the above time frame will lead to the automatic rejection of their bid. The contractor must also ensure that all subcontractors to be used on the project complete this form and submit it to the County for approval within 5 days of the preconstruction meeting. Failure to do so may lead to the rejection of the subcontractor at the County's discretion. Within a reasonable time following its receipt of the completed CCA-2, and based on the information contained therein, information available from OHSa, DOL, federal and state databases of debarred firms, the state Corporate/Entity Database and other sources, its receipt of proof of the bidder's ability to secure required bonding and insurances, and its own independent investigation, the County will determine whether the bidder is a "responsible bidder" qualified to undertake and complete the Project.

Currently the Commissioner of Public Works has approved the CCA-2 (New York State Vendor Responsibility Questionnaire For-Profit Construction) with attachments A, B, and C to serve as the Cattaraugus County Vendor Responsibility Form.

1.3 BID GUARANTEE

Proposals shall be accompanied by a bid guarantee in the form of a certified check, cashier's check, or bid bond in the amount of five percent (5%) of the total amount bid. It shall be made payable to "Treasurer, Cattaraugus County".

1.4 DELIVERY OF BIDS

Each bid must be submitted in duplicate in a sealed envelope clearly marked to indicate its contents. Sealed bids must be delivered to the Cattaraugus County Commissioner of Public Works at or before the date, time and location specified herein. No responsibility shall be attached to the Commissioner of Public Works or his representatives for the premature opening of any bid not properly labeled. Bidders assume all responsibilities and risks associated with mail or courier delivery. When sent by mail, the sealed bid must be addressed to the County at the address and in care of the official in whose office bids are to be received. All bids shall be filed prior to the time and at the place specified in the "Notice to Bidders". Bids received after the time for opening of bids will be returned to the bidder unopened.

1.5 NOTICE OF SPECIAL CONDITIONS

The contractor's attention is particularly called to those parts of the contract documents and specifications which deal with the following:

- A. Insurance requirements – Item 6.4
- B. New York State Department of Transportation Special Conditions included in Section F – Special Notes.
- C. Prevailing wage rates required by N.Y.S. Labor Law and federal Davis-Bacon wage rates – Section I

1.6 DISQUALIFICATION OF BIDDERS

Any one or more of the following may be considered as sufficient cause for the disqualification of a bidder and the rejection of his bid.

- (a) More than one bid for the same work from an individual, firm or corporation under the same or different names.
- (b) Evidence of collusion among bidders. Participants in such collusion will receive no recognition as bidders for any future work with the County until any such participant shall have been reinstated as a qualified bidder.
- (c) Lack of competency and adequate machinery, plant and other equipment, as revealed by the financial statements and experience questionnaire.
- (d) Unsatisfactory performance record as shown by past work for any owner judged from the standpoint of workmanship and progress.
- (e) Uncompleted work which, in judgment of the County, might hinder or prevent the prompt completion of this work if awarded.
- (f) Failure to pay, or satisfactorily settle, all bills due for labor and materials on former contracts in force at the time of letting.
- (g) Failure to comply with any qualification regulations of the County.

1.7 REJECTION OF BIDS

The County reserves the right to reject any bid if the evidence submitted by, or investigation of, such bidder fails to satisfy the County that such bidder is properly qualified to carry out the obligations of the contract and to complete the work contemplated therein. Conditional bids will not be accepted.

PART 2 AWARD AND EXECUTION OF CONTRACT

2.1 CONSIDERATION OF BIDS

In accordance with Section 102-04 of the 2019 Standard Specifications, after the bids are opened and read, they will be compared on the basis the current gross summary in a manner hereafter described for which the work will be performed according to the plans and specifications together with the unit price for each of the separate items as called for. The lowest bid shall be determined by the County based on the criteria shown on page A-1, arrived at by a correct computation of all items specified in the bid therefore at the unit prices stated in the bid. If a conflict arises within the bid, then the words will be used for the final tabulation.

The right is reserved to reject any or all bids, to waive technicalities, to advertise for new bids, or to proceed to do the work otherwise, if in the judgment of the Commissioner the best interests of the County will be promoted thereby.

2.2 CANCELLATION OF AWARD

The County reserves the right to cancel the award of any Contract at any time before the execution of the Contract by all parties without any liability against the County.

2.3 RETURN OF BID GUARANTEE

All bid guarantees, except those of the three lowest bidders, will be returned immediately following the opening and checking of bids. That of the successful bidder will be returned after a satisfactory bond has been furnished and the Contract has been executed. The remaining two guarantees will be returned within ten (10) calendar days following the award of the Contract.

2.4 BONDS

The successful bidder shall at the time of the execution of the Contract, furnish a performance bond and a payment bond each in an amount equal to the full amount of the Contract. The purpose of such bonds is to assure the faithful performance of this Contract as well as the payment of all persons performing labor and furnishing materials in connection with this Contract. The form of the bonds and the security shall be acceptable to the County.

Negotiable securities, satisfactory to the County, in an amount equal to that specified for the Contract bond, may be deposited with the County in lieu of such Contract bond and shall be subject to all the conditions of such bond and to such agreements as may be required by the County.

2.5 FAILURE TO EXECUTE CONTRACT

Failure of the Contractor to execute the Agreement and file acceptable performance and payment bonds within ten (10) calendar days from the date of the *Notice of Award* (see form on page E-20) or after he has received the Contract form shall be just cause for annulment of the award, and for the forfeiture of the bid guarantee. The bid guarantee shall become the property of the County, not as a penalty, but in liquidation of damages sustained. Award may then be made to the next lowest responsible bidder or the work may be re-advertised and constructed under a new Contractor or otherwise as the County may decide.

PART 3 SCOPE OF WORK

3.1 RESPONSIBILITY OF THE CONTRACTOR

The Contractor will be held responsible for the execution of a satisfactory and complete price of work, in accordance with the true intent of the drawings and specifications. He shall provide, without extra charge, all incidental items required as a part of his work including layout and survey, even though not particularly specified or indicated. If he has good reason for objecting to the use of any material, appliance, or method of construction as shown or specified, then he shall report such objections to the Engineer, and if approved by the Engineer, shall obtain proper adjustment before the Contract is made, and then shall proceed with the work with the understanding that a satisfactory job will be required. The Contractor is solely responsible for site safety and adherence to OSHA regulations.

General Scope of Work:

- Class A containment System for Paint Removal;
- Cleaning, Priming, and Painting of Steel;
- Treatment and Disposal Coating Waste and Lead-Based Coating Waste;
- Maintenance and protection of Traffic;
- And whatever incidental work and appurtenances that are necessary to completely and satisfactorily complete the project.

All bridges shall be cleaned, primed, and painted in accordance to New York State Department of Transportation specifications.

This work shall be done in accordance with these contract documents, technical specifications and plans, and as directed by the Owner's Representative.

3.2 ONE-CALL NOTIFICATION TRAINING CERTIFICATION

The Contractor certifies that its excavator(s), operator(s), and/or subcontractor(s), if any, have completed the training and education program provided by the One-Call Notification System pursuant to Article 36 of the NYS General Business Law and any other provider authorized by the Public Service Commission to administer such training and education program. The Contractor shall submit certificates of training with its bid.

PART 4 CONTROL OF WORK

4.1 AUTHORITY OF ENGINEER

The Commissioner of Public Works will be represented by the Engineer who will observe the work done under the Contract on a full time basis throughout construction.

The Engineer shall inspect work performed, review materials to be used, and stop and reject work and materials found to be not in accordance with the plans and specifications. His authority shall cover all phases of the work. In the event that questions should arise concerning the interpretation or changes of plans and specifications or to the acceptability of the work, the Contractor shall submit his questions, in writing, to the Engineer. These questions shall be forwarded to the Commissioner of Public Works along with the Engineer's recommendations.

The Engineer may place on the job other personnel who shall observe the work as his direct representatives. Their authority shall consist of observing the work under the Contract, rejecting any defective material used and temporarily suspending any work improperly performed. They will not have any authority to make changes or alterations in the plans and specifications, nor be permitted to act as foremen for the Contractor.

Any work done or materials used without scheduling suitable observation by the Engineer or his authorized representative as noted in Section D may be ordered removed and replaced at the Contractor's expense.

4.2 SUBSTANTIAL COMPLETION AND FINAL ACCEPTANCE OF WORK

When in the opinion of the Engineer, the Contractor has substantially completed the project or a specified area of a project so that the County can occupy or utilize the project for the use it was intended, the Engineer shall recommend to the Commissioner of Public Works to issue a Certificate of Substantial Completion (See form on page E-22).

When in the opinion of the Engineer the Contractor has fully performed the work under the Contract, the Engineer shall recommend to the Commissioner of Public Works the acceptance of the work so completed. If the Commissioner of Public Works accepts the recommendation of the Engineer, then he shall notify the Contractor by letter of such acceptance, and copies of such acceptance shall be sent to other interested parties.

4.3 CONTRACTOR'S PERSONNEL

The Contractor shall place in charge of the work a competent and reliable English-speaking Superintendent, who shall have the authority to act for the Contractor and who shall be acceptable to the Engineer. This Superintendent must be present at all times during the working day to receive directions and orders given by the Engineer or his representatives. All workers must have sufficient skill and experience to properly perform the work assigned to them. Any person employed by the Contractor who the Engineer may deem incompetent or unfit to perform the work shall at once be discharged and shall not again be employed on projects for the County at that specific task.

4.4 COOPERATION WITH UTILITIES

It shall be the Contractor's duty to notify all utility companies or other parties affected within a time frame as not to affect the schedule prior to all necessary adjustments of the public or private utility fixtures and other appurtenances within or adjacent to the limits of construction. The Contractor shall notify the Engineer in writing describing the need for, and extent of, utility adjustments and the anticipated schedule.

It is understood and agreed upon that the Contractor has considered in his bid all of the permanent and temporary utility appurtenances in their present or relocated positions as shown on the plans and that no additional compensation will be allowed for any delays, inconveniences, or damage sustained by him due to any interference from the utility appurtenances or the operation of moving them by the utility owners. The Contractor will be responsible for any fees required by the utility owners for temporary locations.

PART 5 CONTROL OF MATERIALS

5.1 CERTIFICATE OF ACCEPTABILITY

All certificates of acceptability of materials required by the specifications shall be supplied by the Contractor at no expense to the County. The Engineer shall have the right to approve of the laboratories or fabricators which will issue the certificates.

The cost of the inspection by the Engineer of any plants not approved by the New York State Department of Transportation shall be borne by the Contractor. This shall include, but not be limited to, plants employed to provide mobile concrete and steel reinforcement.

PART 6 LEGAL RELATIONS AND RESPONSIBILITY TO THE PUBLIC

6.1 SUBCONTRACTORS, MATERIALMEN AND LABORERS

The Contractor shall furnish the Engineer, before final payment is authorized, an affidavit that all labor and material associated with the work in any way is paid for in full. The Contractor shall indemnify and hold the County and the Engineer harmless from any lien or claim which may be made or filed after such payment by any subcontractor, materialman or laborer in connection with work performed hereunder.

6.2 RESPONSIBILITY FOR DAMAGE CLAIMS

The Contractor shall indemnify and save harmless Cattaraugus County, its officers, and employees and Greenman-Pedersen, Inc., from all suits, actions, or claims of any character brought because of any injuries or damage received or sustained by any person, persons, or property on account of the operations of the Contractor; or on account of or in consequence of any neglect in safeguarding the work; or through use of unacceptable materials in constructing the work; or because of any act or omission, neglect, or misconduct of the Contractor; or because of any claims or amounts recovered from any infringements of patent, trademark, or copyright; or from any claims on amounts arising or recovered under the Workers' Compensation Law, or any other law, ordinance, order, or decree; and so much of the money due the Contractor under and by virtue of his Contract as shall be considered necessary by the County for such purpose, may be retained for the use of the County; or, in case no money is due, his surety may be held until such suit or suits, action or actions, claim or claims for injuries or damages as aforesaid shall have been settled and suitable evidence to that effect furnished to the County; except that money due the Contractor will not be withheld when the Contractor produces satisfactory evidence that he is adequately protected by public liability and property damage insurance.

The Contractor agrees to make no claim for damages for delay in the performance of this contract occasioned by any act or omission to act of the County or Greenman-Pedersen, Inc., or any of its representatives, and the Contractor agrees that any such claim shall be fully compensated for by an extension of time to complete the performance of work as provided herein.

6.3 NO WAIVER OF LEGAL RIGHTS

The County shall not be precluded or stopped by a measurement, estimate or certificate made either before or after the completion and acceptance of the work and payment therefore, from showing the true amount and character of the work performed and materials furnished by the Contractor, nor from showing that any such measurement, from recovering from the Contractor or his sureties, or both, such damage as it may sustain by reason of his failure to comply with the terms of the Contract. Neither the acceptance by the County, or any representative of the County, nor any extension of time, nor any possession taken by the County shall operate as a waiver of any portion of the Contract or of any power herein reserved, or of any right to damages. A waiver of any breach of the Contract shall not be held to be a waiver of any other or subsequent breach.

6.4 INSURANCE

The Contractor shall procure and maintain at its own expense and without expense to the County, until final acceptance by the County, of the work covered by the contract, insurance for liability for damages imposed by law, of the kinds and in the amounts hereinafter provided, with insurance companies authorized to do such business in the County covering all operations under the contract whether performed by it or its subcontractors. Within ten (10) days of the Notice to Award and prior to the commencement of any work the Contractor shall furnish to the Cattaraugus County Personnel Officer a certificate or certificates of insurance in form satisfactory to the Cattaraugus County Personnel Officer showing that it has complied with this Section, which certificate or certificates shall provide that the policies shall not be changed or canceled until thirty (30) days written notice has been given to the Cattaraugus County Personnel Officer. Failure to supply a satisfactory certificate with ten (10) days after the Notice of Award may result in the cancellation of award and for the forfeiture of the Contractor's bid security, in the sole discretion of the County. The types of insurance are as follows:

- A. **Workers' Compensation Insurance.** A policy covering the obligations of the Contractor in accordance with the provisions of the Workers' Compensation Law, covering all operations under the contract, whether performed by it or its subcontractor and also under the Disability Benefits Law. The contract, shall be void and of no effect unless the person or corporation making or executing same shall secure compensation and disability benefits coverage for the benefit of, and keep insured during the life of the contract, such employees in compliance with the provisions of the Workers' Compensation Law.

- B. **Liability and Property Damage Insurance.** Policies following the 1986 Insurance Services Office formats shall be provided. Unless otherwise specifically required by special provision, each policy shall not be amended or contain deductible clauses or coverage exclusions of any nature and shall have limits not less than shown on page E-16, **Type A – Construction & Maintenance.**

For all damages arising during the policy period, shall be furnished in the types (a1.) through (e.) as described below. An umbrella type policy, dedicated to this contract, may be used to meet these limits.

- a1. Contractor's Liability Insurance issued to and covering the liability for damages imposed by law upon the Contractor with respect to all work performed by him under the agreement;
- a2. Contractor's Liability Insurance issued to and covering the liability for damages imposed by law upon EACH SUBCONTRACTOR with respect to all work performed by said subcontractor under the agreement;
- b. Contractor's Protective Liability Insurance issued to and covering the liability for damages imposed by law upon the Contractor with respect to all work under the agreement performed for the Contractor by subcontractors;
- c. Completed Operations' Liability Insurance issued to and covering the liability for damages imposed by law upon the Contractor and each subcontractor arising between the date of final cessation of the work and the date of final acceptance thereof, out of

that part of the work performed by each;

- d. Protective Liability Insurance issued to and covering the liability for damages imposed by law upon Cattaraugus County and the Commissioner of Public Works and all employees of the County and the County both officially and personally, any municipality in which the work is being performed, and/or any public benefit corporation, railroad, or public utility whose property or facilities are affected by the work or any consultant inspecting engineer or inspector working for or on the project, and their agents or employees,, with respect to all operations under the agreement by the Contractor or its subcontractors, including omissions and supervisory acts of the State, municipality, public benefit corporation or consultant. Specifically, this includes, but is not necessarily limited to the parties listed below.

Failure to list a firm, organization or municipality, etc. does not eliminate the requirement to provide such coverage.

If the Contractor elects to use the same policy for more than one project, then it must provide with the insurance certificate the Aggregate Limits of Insurance (per project) Endorsement indicating the specific project site and contract number;

- e. Commercial General Liability (Premises, Existence, Hazard) Liability Insurance (formerly called Owner's, Landlord's and Tenant's Liability Insurance) issued to and covering the liability for damages imposed by law upon Cattaraugus County and the Commissioner of Public Works and all employees of the County and the County both officially and personally, any municipality in which the work is being performed, and/or any public benefit corporation, railroad, or public utility whose property or facilities are affected by the work or any consultant inspecting engineer or inspector working for or on the project, and their agents or employees, with respect to temporarily opening any portion of the County construction project under this agreement, until the construction or reconstruction pursuant to the agreement has been accepted by the County. Specifically, this includes, but is not necessarily limited to the parties listed on page E-14.

Failure to list a firm, organization or municipality, etc. does not eliminate the requirement to provide such coverage. This coverage will not be required for contracts involving only turf establishment, landscaping, or traffic signals, which do not involve work on the roadway.

- C. Automobile Liability and Property Damage Insurance. A policy covering the use in connection with the work covered by the Contract Documents of all owned, non-owned and hired vehicles bearing, or, under the circumstances under which they are being used, required by the Motor Vehicle Laws of the State of New York to bear license plates.”

List of Additional Insured Parties

County of Cattaraugus
Greenman-Pedersen, Inc.

6.5 LITIGATION

In the event any litigation shall arise from this contract, the laws of the State of New York shall control any litigation, regardless of which party shall institute such action.

COUNTY OF CATTARAUGUS STANDARD INSURANCE REQUIREMENTS

The insurance companies providing these coverages acknowledge that the Named Insured is entering into a contract with the County of Cattaraugus in which the Named Insured agrees to defend, hold harmless, and indemnify the County, its officials, employees, and agents against all claims resulting from work performed, material handled, and services rendered. In some circumstances it will be necessary to require alternate coverage and limits which will be defined in the bid specifications, contract, lease or agreement. The alternate coverage and limits should be evidenced on the certificate in lieu of the standards printed below.

Minimum Coverage Limits are as Follows:

	A Construction & Maintenance	Aa Low Risk Construction & Maintenance	C Professional	D Property Leased to Others or Use of Facilities	F Livery	G All Purpose Public Entity, Concessionaire	Ga Low Risk All Purpose Public Entity
* ** COMMERCIAL GENERAL LIABILITY	\$2,000,000 Agg. \$1,000,000 Occ.	\$1,000,000 Agg. \$ 500,000 Occ.	\$2,000,000 Agg. \$1,000,000 Occ.	\$2,000,000 Agg. \$1,000,000 Occ.	\$2,000,000 Agg. \$1,000,000 Occ.	\$2,000,000 Agg. \$1,000,000 Occ.	\$1,000,000 Agg. \$ 500,000 Occ.
Prem. - Ops.	Include	Include	Include	Include	Include	Include	Include
Prods. - Compl. Ops.	Include	Include	Include	Include	Include	Include	Include
Indep. Contractor	Include	Include	Include	Include	Include	Include	Include
Contractual	Include	Include	Include	Include	Include	Include	Include
BF Property Damage	Include	Include	Include	Include	Include	Include	Include
X,C,U	Include	Include	Include	Include	Include	Include	Include
Personal Injury	Include	Include	Include	Include	Include	Include	Include
Liquor Law							
Host Liquor							
** AUTO LIABILITY	\$1,000,000 CSL	\$1,000,000 CSL	\$1,000,000 CSL	\$1,000,000 CSL	\$1,000,000 CSL	\$1,000,000 CSL	\$1,000,000 CSL
Owned	Include	Include	Include	Include	Include	Include	Include
Hired	Include	Include	Include	Include	Include	Include	Include
Non-Owned	Include	Include	Include	Include	Include	Include	Include
*** EXCESS LIABILITY	\$3,000,000	\$1,000,000	\$1,000,000	\$1,000,000	\$3,000,000	\$1,000,000	
WORKERS' COMP. DISABILITY	Per attached information sheet	Per attached information sheet	Per attached information sheet	Per attached information sheet	Per attached information sheet	Per attached information sheet	Per attached information sheet
EMPLOYER'S LIABILITY	Unlimited	Unlimited	Unlimited	Unlimited	Unlimited	Unlimited	Unlimited
*** PROFESSIONAL LIAB.		\$3,000,000 Agg. \$1,000,000 Occ.					

* The Comprehensive/Commercial General Liability limits can be met by one or more policies, or in combination with an Excess and/or Umbrella Liability policy. The COI must indicate if the coverage trigger in an 'Occurrence' form or a 'Claims-made' form.

All 'Claims-made' policies shall continue to provide evidence of coverage three (3) years after completion of work or product delivery.

** Cattaraugus County MUST be named as Additional Insured for all acts of Named Insured pursuant to this contract.

*** Professional Liability policies are not required to have the County as Additional Insured

Each policy, as allowed by law, shall be endorsed stating that the contractor's insurers agree to waive any rights of subrogation against the County of Cattaraugus because of payments for any injury or damages arising out of work performed under this contract.

PART 7 PROSECUTION AND PROGRESS

7.1 NOTICE TO PROCEED

The "Notice to Proceed" (see form on page E-21) will stipulate the date on which it is expected the Contractor will begin the work. Commencement of work by the Contractor shall be deemed and taken as a waiver of this notice on his part. In no case, however, shall the Contractor begin work prior to the date of the signing of the Contract.

7.2 PROSECUTION OF WORK

The Contractor shall start construction operations on the part of the project approved by the Engineer, or set forth in the approved Progress Schedule. The work shall be conducted in such manner and with sufficient materials, equipment, and labor as are considered necessary to insure its completion in accordance with the plans and specifications as interpreted by the Engineer, by the date set forth in the Agreement. Should the prosecution of the work for any reason be discontinued, the Contractor shall notify the Engineer at least 24 hours in advance of resuming operations.

7.3 TEMPORARY SUSPENSION OF WORK

The Engineer shall have the authority to suspend the work wholly or in part by written order for such period as he may deem necessary due to unsuitable weather, to conditions considered unfavorable for the suitable prosecution of the work, or to carry out orders given or to perform any provisions of the Contract.

7.4 DATE OF COMPLETION OF CONTRACT WORK

The Contractor shall perform fully, entirely, and in a satisfactory and acceptable manner the work contracted, by the date stipulated in the Agreement.

In adjusting the Agreement date for the completion of the project, all strikes, lock-outs, unusual delays in transportation, or any condition over which the Contractor has no control, and also any suspensions ordered by the Engineer for causes not the fault of the Contractor, shall be excluded from the computation of the contract time for completion of the work. No allowance will be made for delays or suspensions of the prosecution of the work due to the fault of the Contractor.

7.5 TERMINATION OF CONTRACT

If the Contractor is adjudged bankrupt or makes an assignment for the benefit of creditors or a receiver is appointed for the Contractor or any insolvency arrangement proceedings are instituted by or against him, or if the Contractor fails after seven (7) days notice to supply enough properly skilled workers or proper materials or fails to prosecute the work with such diligence as will insure its completion by the Agreement date or shall in any other respect commit a breach of his Agreement and fail to remedy the same within seven (7) days after notice thereof, then the County may, by twenty-four (24) hours written notice, terminate the Contractor's right to proceed with the balance of the work or with any portion thereof and may take possession of the work and complete it by

Contract or otherwise. The County may utilize such materials, plant and equipment as may be on the site of the work.

7.6 FAILURE TO COMPLETE WORK ON TIME

When the work embraced in the Contract is not completed on or before the date specified therein, engineering and inspection expenses incurred by the County upon the work from the completion date originally fixed in the Agreement to the final date of completion of the work may be charged to the Contractor and be deducted by the County from any payment due the Contractor. Consideration of any extra work or supplemental Contract work added to the original Contract as well as extenuating circumstances beyond the control of the Contractor, will be given due consideration by the County before assessing engineering and inspection charges against the Contractor. The Contractor will be responsible for any delays resulting from causes within the Contractor's control, including inefficient operations, and the Commissioner of Public Works shall be the sole judge of whether such charges shall be assessed against the Contractor.

The beginning and ending dates of the allowable period of construction will be stipulated in the New York State Department of Environmental Conservation (NYSDEC) and/or Army Corps of Engineers wetland permits. If work is performed outside the stipulated period of time, then the Contractor will be subject to pay any fines resulting from violation of the permits.

7.7 ASSIGNMENT

Assignment of the contract shall be in accordance with Section 109 of the General Municipal Law as follows:

§109. Assignment of public contracts

1. A clause shall be inserted in all specifications or contracts hereafter made or awarded by any officer, board or agency of a political subdivision, or of any district therein, prohibiting any contractor, to whom any contract shall be let, granted or awarded, as required by law, from assigning, transferring, conveying, subletting or otherwise disposing of the same, or of his right, title, or interest therein, or his power to execute such contract, to any other person or corporation without the previous consent in writing of the officer, board or agency awarding the contract.
2. If any contractor, to whom any contract is let, granted or awarded, as required by law, by any officer, board or agency of a political subdivision, or of any district therein, shall without the previous written consent specified in subdivision one of this section, assign, transfer, convey, sublet or otherwise dispose of such contract, or his right, title, or interest therein, or his power to execute such contract, to any other person or corporation, the officer, board or agency which let, made, granted or awarded such contract shall revoke and annul such contract, and the political subdivision or district therein, as the case may be, and such officer, board or agency shall be relieved and discharged from any and all liability and obligations growing out of such contract to such contractor, and to the person or corporation to which such contract shall have been assigned, transferred, conveyed, sublet or otherwise disposed of, and such contractor, and his assignees, transferees or sublessees shall forfeit and lose all moneys theretofore earned under such contract, except so much as may be required to pay his employees. The provisions of this section shall not hinder, prevent, or affect an assignment by any such contractor for the benefit of his creditors made pursuant to the laws of this state.

PART 8 MEASUREMENT AND PAYMENT

8.1 PAYMENTS ON CONTRACT

Payments to the Contractor for work satisfactorily completed will be made monthly in the amount of the work completed. No monthly payment will be rendered for less than 10% of the Contract amount or \$10,000, whichever is less. The payments will be based on the completed percentage of each unit bid as shown in the Itemized schedule.

The attention of persons intending to make proposals is specifically called to the provisions of Section 70 and 71 of the Lien Law in relation to funds being received by a Contractor for a public improvement. These provisions declare that the funds received by the Contractor shall constitute trust funds in the hands of such Contractor to be applied first to the payment of certain claims.

No certificate approving or authorizing the first partial payment, or in the event taxes shall be found due in accordance with this Section after the first payment to the Contractor, then no certificates approving or authorizing any final payment shall be made to a foreign Contractor unless such Contractor furnishes satisfactory proof that all taxes due by such Contractor under the provisions of Articles 9, 9A, 16, and 16A of the Tax Law have been paid. The certificate of the State Tax Commission to the effect that all such taxes have been paid shall be conclusive proof of the payment of such taxes.

The term "Foreign Contractor" as used in the preceding paragraph means in the case of an individual, a person who is a legal resident of another state or foreign country; and in the case of a firm or co-partnership, one having one or more partners who is a legal resident of another State or foreign country and in the case of a corporation, one having its principal place of business in another State or foreign country.

8.2 DIFFERING SITE CONDITIONS

The Contractor shall promptly, and before the conditions are disturbed, give a written notice to the Engineer of (1) subsurface or latent physical conditions at the site which differ materially from those indicated in this contract, or (2) unknown physical conditions at the site of an unusual nature, which differ materially from those ordinarily encountered and generally recognized as inhering in work of the character provided for in the contract.

The Engineer shall investigate the site conditions promptly after receiving the notice. If the conditions do materially so differ and cause an increase or decrease in the Contractor's cost of, or the time required for, performing any part of the work under this contract, whether or not changed as a result of the conditions, then an equitable adjustment shall be made under this clause and the contract modified in writing accordingly. The Contractor shall not have rights to suspend work during resolution of a differing site condition as stipulated in Section 105-14 of the Standard Specifications.

No request by the Contractor for an equitable adjustment to the contract under this clause shall be allowed, unless the Contractor has given the written notice required; provided, that the time prescribed above for giving written notice may be extended by the Engineer.

NOTICE OF AWARD

TO: _____

PROJECT Description:

2020 Bridge Painting Program
Cattaraugus County, New York

The County has considered the Bid submitted by you for the above-described work in response to its Advertisement for Bid No. _____ opened _____.

You are hereby notified that your Bid has been accepted in the amount of \$ _____

You are required by the General Provisions to execute the Agreement and furnish the required Contractor's Performance Bond and Payment Bond within ten (10) calendar days from the date of this Notice of Award.

If you fail to execute such Agreement and to furnish the Bonds within the ten (10) days from the date of this Notice, then the County will be entitled to consider all your rights arising out of Cattaraugus County's acceptance of your Bid as abandoned and as a forfeiture of your Bid Bond. Cattaraugus County will be entitled to such other rights as may be granted by law.

You are required to return an acknowledged copy of this Notice of Award to Cattaraugus County.

Dated this _____ day of _____ in the year _____.

OWNER: Cattaraugus County

BY: _____

TITLE: _____

ACCEPTANCE OF NOTICE

Receipt of the above NOTICE OF AWARD is hereby acknowledged by

Dated this _____ day of _____ in the year _____.

By: _____

Title: _____

NOTICE TO PROCEED

DATE:

PROJECT:

2020 Bridge Painting Program
Cattaraugus County, New York

TO: _____

You are hereby notified to commence work in accordance with the Agreement dated _____ on or after _____. All work shall be completed on or before October 31, 2020 and final payment shall be submitted within 45 calendar days of completion of work.

You are required to return an acknowledged copy of this Notice of Proceed to Cattaraugus County

CATTARAUGUS COUNTY

Owner

By: _____

Title: _____

ACCEPTANCE OF THIS NOTICE

Receipt of the above Notice to Proceed is hereby acknowledged by

Dated this _____ day of _____ in the year _____.

By: _____

Title: _____

CERTIFICATE OF SUBSTANTIAL COMPLETION

DATE:

PROJECT:

2020 Bridge Painting Program
Cattaraugus County, New York

TO: _____

The performed under this contract has been inspected by authorized representatives of the County, Contractor and Engineer and the Project was found to be substantially completed in accordance with the contract documents.

DEFINITION OF SUBSTANTIAL COMPLETION

The date of substantial completion of a project or a specified area of a project is the date when the construction is sufficiently completed, in accordance with the contract documents, as modified by any change orders agreed to by the parties, so that the County can occupy or utilize the project or specified area of the project for the use it was intended.

A tentative list of items to be completed or corrected is attached hereto. This list may not be exhaustive, and the failure to include an item on it does not alter the responsibility of the Contractor to complete all the work in accordance with the contract documents

Engineer

By _____
Authorized Representative

Date _____

The Contractor accepts the above Certificate of Substantial Completion and agrees to complete and correct the items on the tentative list with the time indicated.

Contractor

By _____
Authorized Representative

Date _____

The County Accepts the project or specified area of the project as substantially complete and will assume full possession of the project or specified are of the project at _____(time), on _____(date).

Cattaraugus County

By _____
Authorized Representative

Date _____

SECTION F

SPECIAL NOTES

The Contractor's attention is specifically called to Section 102-08 of the State of New York Department of Transportation (NYSDOT), Office of Engineering, Standard Specifications, Construction and Materials (US Customary) of January 1, 2020.

- The Northern Long Eared Bat (*Myotis Septentrionalis*) is listed as a Federally threatened species statewide. This project is not anticipated to involve the removal of trees greater than three (3) inches in diameter (diameter breast height (DBH)). If project conditions change and tree removals are necessary, whether under clearing and grubbing or tree removals, the Engineer must be notified prior to the start of any tree removals. Tree removals will be allowed only after coordination and approval by the Engineer in consultation with the Construction Environmental Coordinator.
- All bridges have the potential of being summer roosting habitat for the northern long-eared bat (NLEB). The contractor shall notify the EIC at least 10 days prior to the start of work at each bridge. A bridge/bat survey will be conducted by the County for the presence of the NLEB for any bridge work that will take place between March 31 and October 1 and/or involves access to the underside of the bridge or drilling down to the underside of the bridge, including bridge painting and washing. The survey will be conducted and results provided within seven (7) days of the contractor's notification. No work on that bridge can commence until the bridge is cleared through the EIC.

OPERATIONAL DAMAGES

The Contractor will be held entirely responsible for any damages to adjacent property as a result of his operations.

The Contractor shall protect all trees and shrubs in an approved manner, which may include fences and boards lashed to trees to prevent damage from machine operations. He shall prevent damage to pipes, conduits and other underground structures and all land monuments and property marks.

The Contractor shall be responsible for all fire on the site of the work whether started by himself or others and no materials shall be burned on the site, except with the approval of the Engineer and not without first obtaining permits from the proper municipal authorities.

LATE DELIVERY OF MATERIAL IN SHORT SUPPLY

In the event the delivery of any material in short supply is delayed substantially beyond the normal delivery time which results in delaying the completion of the contract, the contract will be extended without the assessment of engineering charges. The Contractor shall, however, demonstrate to the Engineer that he has made every reasonable effort to obtain such material and complete the contract.

EXCAVATION

The Contractor's attention is called to the fact that any contours shown in the plans are approximate, and in any event, they are not to be deemed or considered by the Contractor as a warranty or a representation by the Engineer of exact field conditions.

SITE SAFETY

The Contractor shall perform all work in the Contract Documents in a workmanlike manner with due regard to the safety of the employees and of the public. The Contractor shall comply with all rules, regulations and standards of the Occupational Safety and Health Administration, U.S. Department of Labor in the performance of the work required by the Contract Documents in all matters regarding the safety and protection of persons employed in construction, excavation and demolition work. The contractor shall also meet all applicable requirements of the State of New York Department of Labor, Industrial Code Rule 53 regarding construction, excavation and demolition operations at or near underground facilities. The Contractor is fully and solely responsible for site safety precautions.

The Contractor shall be responsible for initiating, maintaining and supervising all safety precautions and programs in connection with the work. The Contractor shall take all necessary precautions for the safety of, and shall provide the necessary protection to prevent damage, injury or loss of:

- a) all employees on the site and other persons who may be affected thereby;
- b) all the work and all products to be incorporated therein, whether in storage on or off the site; and
- c) other property at the site or adjacent thereto, including trees, shrubs, lawns, walks, pavements, roadways, structures and utilities not designated for removal, relocation or replacement in the course of construction.

Contractor shall assume all responsibility for damage to persons or property which may occur during the prosecution of the work and shall replace or make good any such damage, loss or injury.

UTILITIES, GENERAL

Utilities encountered during the work shall be maintained and protected in their existing locations until otherwise provided for. If services or utility lines not shown on the plans are encountered, then excavation and grading shall be done with caution in order that these services not be disturbed until proper disposition of such is made by their owners. Damage by the Contractor to privately owned utilities shall be in all cases the responsibility of the Contractor. Relocation of public utilities and accessories is a responsibility of the servicing agency. Every reasonable attempt will be made by the agents of the Cattaraugus County Department of Public works not to inconvenience or additionally cost the Contractor due to such locations relating to time and/or place; however, no extra compensation will be made to the Contractor by the County of Cattaraugus for extra work or loss of time due to such utilities or the removal or relocation of such utilities.

The Contractor shall notify the Engineer, in writing, at least fourteen (14) days in advance of any work which may affect any utility or cause an interruption or disruption of utility service.

VEHICLE WEIGHTS

The Contractor shall submit to the Engineer the weights of the construction vehicles to be used on the pavement and on the bridge.

MAINTENANCE AND PROTECTION OF TRAFFIC

The Contractor will be responsible for providing traffic control. All traffic control signage and devices shall be accordance with the Contract documents, the National Manual of Uniform Traffic Control Devices, 2009 Edition, and 17 NYCRR Chapter V, 2010 Edition including all revisions. The Contractor shall coordinate with the Underground Facilities Protective Organization (UFPO) prior to driving any sign posts.

PRECONSTRUCTION CONFERENCE AND PROJECT SCHEDULE

The Contractor shall submit to the County and the Engineer a detailed construction schedule acceptable to the Engineer for review prior to the preconstruction conference. The schedule shall be based on the beginning and end of each subtask as outlined in the bid schedule. The Contractor should be represented at the preconstruction conference by those staff to be in responsible charge of the work, including the site superintendent.

SUBLETTING OR ASSIGNING THE CONTRACT

The Contractor shall perform with his own organization contract work amounting to not less than 50 percent of the original total contract price, except that any items designated by the County as "Specialty Items: so performed may be deducted from the original total contract price before computing the amount of work required to be performed by the Contractor with his own organization.

His own organization shall be construed to include only workers employed and paid directly by the Contractor and equipment owned or rented by him, with or without operators.

SPECIALTY ITEMS IN THIS CONTRACT

Item 619.01nnnn Basic Work Zone Traffic Control

SALVAGED MATERIALS

Unless otherwise shown on the plans or specified in the bid, all salvaged material shall become the property of the Contractor.

ORDINANCES AND PERMITS

The Contractor shall comply with, and give all notices required by, all laws, ordinances, rules and regulations bearing on the conduct of the work. He shall procure and pay for all permits and licenses that may be necessary for the completion of the work.

REQUIRED NOTICES

a) Fire and Police Officials

Local fire and police authorities shall be notified by the Contractor in advance of the beginning of the progress of the work in order to coordinate and maintain sufficient fire and police protection.

b) School Officials and Ambulance Companies

The Contractor shall closely coordinate all work impacting school pedestrian and bus traffic with the Engineer. Safe School Route Maintenance Plans shall be submitted by the Contractor and approved by the Engineer prior to construction. The cost of any additional signage, flagpersons or other requirements to maintain school routes throughout the duration of the project shall be included in the Bid price for Item 619.01nnnn.

The Contractor is required to make personal contact with appropriate ambulance companies in respect to the effect of the off-site detour on their operations. This should be done several weeks in advance of changes so that there will be adequate time for them to make necessary adjustments to their schedules and routes.

RIGHT OF WAY

Previously signed contracts or agreements made between the County Department of Public Works and the pertinent landowners must be honored by the Contractor. A list of pertinent signed agreements will be furnished to the Contractor. Any deviations from the above stated contracts or agreements after the contract is awarded must be first stipulated in writing and signed by all interested parties.

ENVIRONMENTAL CONCERNS

At any time the engineer feels work is adversely impacting the river or adjacent properties, he shall order such operations be terminated, and the Contractor must provide the necessary mitigation devices prior to continuing.

In addition to the Nationwide Permit, the Cattaraugus County Department of Public Works holds a General Permit with the New York State Department of Environmental Conservation (NYSDEC). This General Permit covers the following:

- Article 15, Title 5: Protection of Water
- 6NYCRR 608: Water Quality Certification
- Article 24: Freshwater Wetlands

SHOP DRAWINGS

Fifteen (15) days prior to the start of any abrasive-blast cleaning or paint removal work, the Contractor shall submit to the Engineer for approval detailed working drawings and calculations of the Class A containment system for each structure. The drawings shall be prepared and stamped by a Professional Engineer

SAFETY DATA SHEETS

The Contractor is responsible for providing the Safety Data Sheets to the County prior to introducing hazardous materials onto the site, assuring compliance before work is started and disseminating any information to the County employees concerning significant chemical hazards that the Contractor is bringing to the County's workplace. The Safety Data Sheets will be maintained by the County as long as those materials are present. It is the responsibility of the Contractor to train its own employees.

ASBESTOS

There are to be NO asbestos materials used in any work being done for the County. If it is found that products with asbestos materials have been used, then the Contractor will be held responsible for all cost of clean-up, removal and any other cost that may occur because of it.

SUBCONTRACTORS, SUPPLIERS AND MATERIAL SOURCES

The Contractor shall submit to the Engineer for approval at the preconstruction meeting all subcontractors, suppliers and material sources anticipated to be used on the project.

SUBSURFACE CONDITIONS

Not applicable.

LEGAL LOADS

The Contractor is reminded that only legal loads are permitted on public highways. The only

exception to this is an issuance by the County of a Special Hauling Permit for oversize or overweight loads. These permits are issued at the discretion of the County Department of Public Works and only under special conditions over specified highways at designated times and do not apply to the hauling of materials for construction contracts. Weigh slips, which are a part of contract records, are available to enforcing agencies.

If the section of highway under construction is designated as a Restricted Highway by the Commissioner, then only legal loads will be permitted unless otherwise authorized in writing by the Engineer. Such authorization will in general apply only to those portions of the highway that are to be destroyed during construction and generally not newly finished pavement or structures.

It is anticipated that seasonal or weather conditions may frequently require the use of lighter and smaller equipment and loads that might be used under optimum conditions. If the Engineer determines that hauling operations or other movement of heavy equipment is having or may result in detrimental effects on the finished highway, on or off the site, then the Engineer may restrict those operations and/or locations.

EQUIPMENT

RENTAL RATES - A list of equipment to be used in the contract shall be submitted to the Engineer before any work is started. Such list will include all necessary information to ascertain New York State Rental Rates and need not include trucks.

REMOVAL OF COUNTY OR TOWN-OWNED FACILITIES

The Contractor shall give sufficient notice to the Engineer, for removal by Departmental Forces, of such County or Town-owned facilities as signs and delineators.

EXISTING CONDITIONS

All dimensions affected by the geometrics and/or location of the existing structure are to be checked in the field by the Contractor, before ordering or fabricating any materials, and before any construction begins. It shall be the responsibility of the Contractor to supply the Engineer with all field dimensions required to check shop drawings.

INSURANCE

The Contractor shall provide insurance coverage including the project and for a distance of 500 feet beyond the actual construction designated "Contract Begins" and/or "Contract Ends" and 500 feet beyond the "Limit of Work" of all intersecting highways.

UTILITY DISPOSITION

There are no utility relocations expected for this project. The Contractor's attention is directed to the existing, overhead electric and telephone lines that may be located near the roadway. The Contractor shall use caution when performing work in the vicinity of these overhead lines.

EPA NUMBERS

The County will provide EPA numbers if required to remove hazardous paint waste.

PAINT COLOR SELECTION

The finish coat color selection will be made by the County for all the bridges. All County-owned bridges will be painted with the same finish coat color.

The paint color selection will be made from color pallets available from approved paint material vendors and supplied by the Contractor.

SECTION G

SPECIFICATIONS FOR MATERIALS OF CONSTRUCTION

All specifications for materials of construction, unless provided herein, shall conform to Section 700 of the New York State Department of Transportation Office of Engineering Standard Specifications, Construction and Materials (US Customary) of January 1, 2020 and all Addenda.

There are no special specifications used for this project.

SECTION H

TECHNICAL SPECIFICATIONS

1. SPECIFICATIONS

The New York State Department of Transportation Office of Engineering Standard Specifications, Construction and Materials of January 1, 2020, including any addenda to date, are hereby incorporated, in their entirety, and made a composite part of these specifications except as herewith modified and supplemented by these specifications and subsequent documents issued by the County.

The Specifications, Plans and Contract Documents of the County shall govern over those of other agencies but where the method of work and requirements of materials are not included in the Contract Documents of the County, the New York State Department of Transportation Standard Specifications, Construction and Materials of January 1, 2020 including any addenda to date shall govern.

2. DEFINITIONS

Refer to Section D for Definitions and Terms

To avoid excessive overlapping and repetition, there are certain sections, materials and items that are referred to in other items. In these cases, it is understood that the words such as culvert and sewer; sanitary and storm; utility and sewer; manhole and catch basin; structure and culvert; gravel and granular fill or material; select and selected; bituminous and asphalt; etc., are interchangeable. In cases where references are not given and the need arises for a specification, similar sections or related items shall govern.

Whenever the words directed, required, permitted, ordered, instructed, designated, considered necessary, or where the words of like import are used, it shall be understood that the direction, requirement, permission, order, instruction, designation or prescription of the Engineer is intended; and similarly, the words approved, acceptable, satisfactory, or words of like import shall mean approved by or acceptable or satisfactory to the Engineer, unless another meaning is plainly intended. Whenever, in the description of any part of the Work to be done under this Contract, the expression as shown, as shown on the plans or the words of like import are used, it shall be understood to mean as shown on the Contract Drawings, unless another meaning is plainly intended.

SECTION I

**DEPARTMENT OF LABOR CONTRACT REQUIREMENTS
AND PREVAILING WAGE RATE SCHEDULES**

Labor classifications not appearing on the following rate sheets can be used only with the consent of the Commissioner of Public Works and then the rate to be paid will be given by the Commissioner of Public Works after advising with the State Department of Labor.

All requests for minimum wage rates for additional occupations shall be directed through the County.

The bidder shall take into account in his bid all changes in wage rates and supplements that may be forthcoming during the time the contract is in force.

The Contractor in the execution of the work under the contract in accordance with the provisions of the specifications and the special provisions to the specifications may submit job orders to and may also request the referral of lists of qualified applicants for the work of the NEW YORK STATE EMPLOYMENT SERVICE.

PROVISIONS RELATING TO THE NEW YORK STATE LABOR LAW, PREVAILING WAGES, AND THE USE OF CONVICT LABOR AND MATERIALS ON FEDERAL & STATE CONTRACTS

GENERAL PROVISIONS. All projects funded with Federal aid and let to contract in New York State shall conform to the provisions of the New York State Labor Law, except that in accordance with the authorization in Article 4, Section 85 of the New York State Highway Law, any provisions of the above referenced Labor Law which are in conflict with the following enumerated mandatory Federal Aid highway construction compliance requirements, as contained in Section 635 of the Code of Federal Regulations, Title 23 – Highways, and other Federal legislation, rules, and regulations, as referenced below, are superseded:

CONVICT LABOR. No convict labor, unless performed by convicts who are on parole, supervised release, or probation, shall be employed in construction or used for maintenance or any other purposes at the site or within the limits of any Federal Aid highway construction project from the time of award of the contract or the start of work on force account until final acceptance of the work by the Owner.

SELECTION OF LABOR. No procedures or requirements shall be imposed by any state or municipal subdivision thereof which will operate to discriminate against the employment of labor from any other state, possession, or territory of the United States, in the construction of a Federal Aid project. The selection of labor to be employed by the Contractor on any Federal Aid project shall be of his/her own choosing.

WAGE RATES ON FEDERAL AID PROJECTS. Attention is directed to the statutory provisions governing the prevailing rates of wages for workmen, mechanics, and laborers who are employed on this project. Section 220 of the New York State Labor Law, as amended, requires that the wages paid for a legal day's work shall be not less than the rate of wages plus the supplements prevailing at the time the work is performed, the current schedules of which shall be included in the contract documents. Such schedules may be amended or supplemented from time to time, and such amendments or supplements shall be forwarded to the Contractor.

The Federal Aid Highway Act of 1968 provides for the payment of wages at rates not less than those determined in accordance with the Davis-Bacon Act (40 USC, Section 276-a), the schedule of which shall also be included in the contract documents.

On-site materials suppliers, in addition to all subcontractors, are subject to the provisions of the Davis-Bacon Act. This will not necessarily be construed as causing the on-site material suppliers to be classified as subcontractors as part of the 50% limitation on the subcontracting of this project.

In case of a variance between (1) the schedules of prevailing rates of wages and supplements as determined under Section 220 of the New York State Labor Law, and (2) the schedule of rates of wages as determined pursuant to the Davis-Bacon Act, the Contractor shall accept and use the schedule or schedules that establish the higher rate of wages as the minimum for the workmen who are employed on the project.

CONSTRUCTION BY FEDERAL AGENCIES. When construction on Federal Aid highways is being performed by any Federal agency under its procedures and by Federal contract, the labor standards relating to direct federal contracts shall be applicable.

NON-DISCRIMINATION. Employment shall be provided without regard to race, color, religion, sex, or national origin.

CONVICT-PRODUCED MATERIALS. The use of convict-produced materials on any Federal or Federally-assisted contract must comply with the following requirements:

- a. Materials produced by convict labor may only be incorporated in a Federal Aid highway construction project if such materials have been:
 1. Produced by convicts who are on parole, supervised release, or probation from prison;
or
 2. Produced in a qualified prison facility and the cumulative annual production amount of such materials for use in Federal Aid highway construction does not exceed the amount of such materials produced in such facility for use in Federal Aid highway construction during the 12-month period ending July 1, 1987.
- b. “Qualified prison facility” means any prison facility in which convicts, during the 12-month period ending July 1, 1997, produced materials for use in Federal Aid highway construction projects.
- c. Standard State and Federal Aid contract procedures may be used to assure compliance with the requirements of this paragraph.



Andrew M. Cuomo, Governor

Roberta Reardon, Commissioner

Cattaraugus County DPW
Glenn Blake
403 Main Street, Suite 330
Buffalo NY 14203

Schedule Year 2019 through 2020
Date Requested 11/22/2019
PRC# 2019014891

Location Various locations
Project ID#
Project Type Painting 3 roadway bridges

PREVAILING WAGE SCHEDULE FOR ARTICLE 8 PUBLIC WORK PROJECT

Attached is the current schedule(s) of the prevailing wage rates and prevailing hourly supplements for the project referenced above. A unique Prevailing Wage Case Number (PRC#) has been assigned to the schedule(s) for your project.

The schedule is effective from July 2019 through June 2020. All updates, corrections, posted on the 1st business day of each month, and future copies of the annual determination are available on the Department's website www.labor.ny.gov. Updated PDF copies of your schedule can be accessed by entering your assigned PRC# at the proper location on the website.

It is the responsibility of the contracting agency or its agent to annex and make part, the attached schedule, to the specifications for this project, when it is advertised for bids and /or to forward said schedules to the successful bidder(s), immediately upon receipt, in order to insure the proper payment of wages.

Please refer to the "General Provisions of Laws Covering Workers on Public Work Contracts" provided with this schedule, for the specific details relating to other responsibilities of the Department of Jurisdiction.

Upon completion or cancellation of this project, enter the required information and mail **OR** fax this form to the office shown at the bottom of this notice, **OR** fill out the electronic version via the NYSDOL website.

NOTICE OF COMPLETION / CANCELLATION OF PROJECT

Date Completed: _____ Date Cancelled: _____

Name & Title of Representative: _____

Phone: (518) 457-5589 Fax: (518) 485-1870
W. Averell Harriman State Office Campus, Bldg. 12, Room 130, Albany, NY 12240

General Provisions of Laws Covering Workers on Article 8 Public Work Contracts

Introduction

The Labor Law requires public work contractors and subcontractors to pay laborers, workers, or mechanics employed in the performance of a public work contract not less than the prevailing rate of wage and supplements (fringe benefits) in the locality where the work is performed.

Responsibilities of the Department of Jurisdiction

A Department of Jurisdiction (Contracting Agency) includes a state department, agency, board or commission; a county, city, town or village; a school district, board of education or board of cooperative educational services; a sewer, water, fire, improvement and other district corporation; a public benefit corporation; and a public authority awarding a public work contract.

The Department of Jurisdiction (Contracting Agency) awarding a public work contract MUST obtain a Prevailing Rate Schedule listing the hourly rates of wages and supplements due the workers to be employed on a public work project. This schedule may be obtained by completing and forwarding a "Request for wage and Supplement Information" form (PW 39) to the Bureau of Public Work. The Prevailing Rate Schedule MUST be included in the specifications for the contract to be awarded and is deemed part of the public work contract.

Upon the awarding of the contract, the law requires that the Department of Jurisdiction (Contracting Agency) furnish the following information to the Bureau: the name and address of the contractor, the date the contract was let and the approximate dollar value of the contract. To facilitate compliance with this provision of the Labor Law, a copy of the Department's "Notice of Contract Award" form (PW 16) is provided with the original Prevailing Rate Schedule.

The Department of Jurisdiction (Contracting Agency) is required to notify the Bureau of the completion or cancellation of any public work project. The Department's PW 200 form is provided for that purpose.

Both the PW 16 and PW 200 forms are available for completion [online](#).

Hours

No laborer, worker, or mechanic in the employ of a contractor or subcontractor engaged in the performance of any public work project shall be permitted to work more than eight hours in any day or more than five days in any week, except in cases of extraordinary emergency. The contractor and the Department of Jurisdiction (Contracting Agency) may apply to the Bureau of Public Work for a dispensation permitting workers to work additional hours or days per week on a particular public work project.

There are very few exceptions to this rule. Complete information regarding these exceptions is available on the "[4 Day / 10 Hour Work Schedule](#)" form (PW 30.1).

Wages and Supplements

The wages and supplements to be paid and/or provided to laborers, workers, and mechanics employed on a public work project shall be not less than those listed in the current Prevailing Rate Schedule for the locality where the work is performed. If a prime contractor on a public work project has not been provided with a Prevailing Rate Schedule, the contractor must notify the Department of Jurisdiction (Contracting Agency) who in turn must request an original Prevailing Rate Schedule form the Bureau of Public Work. Requests may be submitted by: mail to NYSDOL, Bureau of Public Work, State Office Bldg. Campus, Bldg. 12, Rm. 130, Albany, NY 12240; Fax to Bureau of Public Work (518) 485-1870; or electronically at the NYSDOL website www.labor.ny.gov.

Upon receiving the original schedule, the Department of Jurisdiction (Contracting Agency) is REQUIRED to provide complete copies to all prime contractors who in turn MUST, by law, provide copies of all applicable county schedules to each subcontractor and obtain from each subcontractor, an affidavit certifying such schedules were received. If the original schedule expired, the contractor may obtain a copy of the new annual determination from the NYSDOL website www.labor.ny.gov.

The Commissioner of Labor makes an annual determination of the prevailing rates. This determination is in effect from July 1st through June 30th of the following year. The annual determination is available on the NYSDOL website www.labor.ny.gov.

Payrolls and Payroll Records

Every contractor and subcontractor MUST keep original payrolls or transcripts subscribed and affirmed as true under penalty of perjury. Payrolls must be maintained for at least three (3) years from the project's date of completion. At a minimum, payrolls must show the following information for each person employed on a public work project: Name, Address, Last 4 Digits of Social Security Number, Classification(s) in which the worker was employed, Hourly wage rate(s) paid, Supplements paid or provided, and Daily and weekly number of hours worked in each classification.

The filing of payrolls to the Department of Jurisdiction is a condition of payment. Every contractor and subcontractor shall submit to the Department of Jurisdiction (Contracting Agency), within thirty (30) days after issuance of its first payroll and every thirty (30) days thereafter, a transcript of the original payrolls, subscribed and affirmed as true under penalty of perjury. The Department of Jurisdiction (Contracting Agency) shall collect, review for facial validity, and maintain such payrolls.

In addition, the Commissioner of Labor may require contractors to furnish, with ten (10) days of a request, payroll records sworn to as their validity and accuracy for public work and private work. Payroll records include, but are not limited to time cards, work description sheets, proof that supplements were provided, cancelled payroll checks and payrolls. Failure to provide the requested information within the allotted ten (10) days will result in the withholding of up to 25% of the contract, not to exceed \$100,000.00. If the contractor or subcontractor does not maintain a place of business in New York State and the amount of the contract exceeds \$25,000.00, payroll records and certifications must be kept on the project worksite.

The prime contractor is responsible for any underpayments of prevailing wages or supplements by any subcontractor.

All contractors or their subcontractors shall provide to their subcontractors a copy of the Prevailing Rate Schedule specified in the public work contract as well as any subsequently issued schedules. A failure to provide these schedules by a contractor or subcontractor is a violation of Article 8, Section 220-a of the Labor Law.

All subcontractors engaged by a public work project contractor or its subcontractor, upon receipt of the original schedule and any subsequently issued schedules, shall provide to such contractor a verified statement attesting that the subcontractor has received the Prevailing Rate Schedule and will pay or provide the applicable rates of wages and supplements specified therein. (See NYS Labor Laws, Article 8 . Section 220-a).

Determination of Prevailing Wage and Supplement Rate Updates Applicable to All Counties

The wages and supplements contained in the annual determination become effective July 1st whether or not the new determination has been received by a given contractor. Care should be taken to review the rates for obvious errors. Any corrections should be brought to the Department's attention immediately. It is the responsibility of the public work contractor to use the proper rates. If there is a question on the proper classification to be used, please call the district office located nearest the project. Any errors in the annual determination will be corrected and posted to the NYS DOL website on the first business day of each month. Contractors are responsible for paying these updated rates as well, retroactive to July 1st.

When you review the schedule for a particular occupation, your attention should be directed to the dates above the column of rates. These are the dates for which a given set of rates is effective. To the extent possible, the Department posts rates in its possession that cover periods of time beyond the July 1st to June 30th time frame covered by a particular annual determination. Rates that extend beyond that instant time period are informational ONLY and may be updated in future annual determinations that actually cover the then appropriate July 1st to June 30th time period.

Withholding of Payments

When a complaint is filed with the Commissioner of Labor alleging the failure of a contractor or subcontractor to pay or provide the prevailing wages or supplements, or when the Commissioner of Labor believes that unpaid wages or supplements may be due, payments on the public work contract shall be withheld from the prime contractor in a sufficient amount to satisfy the alleged unpaid wages and supplements, including interest and civil penalty, pending a final determination.

When the Bureau of Public Work finds that a contractor or subcontractor on a public work project failed to pay or provide the requisite prevailing wages or supplements, the Bureau is authorized by Sections 220-b and 235.2 of the Labor Law to so notify the financial officer of the Department of Jurisdiction (Contracting Agency) that awarded the public work contract. Such officer MUST then withhold or cause to be withheld from any payment due the prime contractor on account of such contract the amount indicated by the Bureau as sufficient to satisfy the unpaid wages and supplements, including interest and any civil penalty that may be assessed by the Commissioner of Labor. The withholding continues until there is a final determination of the underpayment by the Commissioner of Labor or by the court in the event a legal proceeding is instituted for review of the determination of the Commissioner of Labor.

The Department of Jurisdiction (Contracting Agency) shall comply with this order of the Commissioner of Labor or of the court with respect to the release of the funds so withheld.

Summary of Notice Posting Requirements

The current Prevailing Rate Schedule must be posted in a prominent and accessible place on the site of the public work project. The prevailing wage schedule must be encased in, or constructed of, materials capable of withstanding adverse weather conditions and be titled "PREVAILING RATE OF WAGES" in letters no smaller than two (2) inches by two (2) inches.

The "Public Work Project" notice must be posted at the beginning of the performance of every public work contract, on each job site.

Every employer providing workers. compensation insurance and disability benefits must post notices of such coverage in the format prescribed by the Workers. Compensation Board in a conspicuous place on the jobsite.

Every employer subject to the NYS Human Rights Law must conspicuously post at its offices, places of employment, or employment training centers, notices furnished by the State Division of Human Rights.

Employers liable for contributions under the Unemployment Insurance Law must conspicuously post on the jobsite notices furnished by the NYS Department of Labor.

Apprentices

Employees cannot be paid apprentice rates unless they are individually registered in a program registered with the NYS Commissioner of Labor. The allowable ratio of apprentices to journeyworkers in any craft classification can be no greater than the statewide building trade ratios promulgated by the Department of Labor and included with the Prevailing Rate Schedule. An employee listed on a payroll as an apprentice who is not registered as above or is performing work outside the classification of work for which the apprentice is indentured, must be paid the prevailing journeyworker's wage rate for the classification of work the employee is actually performing.

NYS DOL Labor Law, Article 8, Section 220-3, require that only apprentices individually registered with the NYS Department of Labor may be paid apprenticeship rates on a public work project. No other Federal or State Agency of office registers apprentices in New York State.

Persons wishing to verify the apprentice registration of any person must do so in writing by mail, to the NYSDOL Office of Employability Development / Apprenticeship Training, State Office Bldg. Campus, Bldg. 12, Albany, NY 12240 or by Fax to NYSDOL Apprenticeship Training (518) 457-7154. All requests for verification must include the name and social security number of the person for whom the information is requested.

The only conclusive proof of individual apprentice registration is written verification from the NYSDOL Apprenticeship Training Albany Central office. Neither Federal nor State Apprenticeship Training offices outside of Albany can provide conclusive registration information.

It should be noted that the existence of a registered apprenticeship program is not conclusive proof that any person is registered in that program. Furthermore, the existence or possession of wallet cards, identification cards, or copies of state forms is not conclusive proof of the registration of any person as an apprentice.

Interest and Penalties

In the event that an underpayment of wages and/or supplements is found:

- Interest shall be assessed at the rate then in effect as prescribed by the Superintendent of Banks pursuant to section 14-a of the Banking Law, per annum from the date of underpayment to the date restitution is made.
- A Civil Penalty may also be assessed, not to exceed 25% of the total of wages, supplements, and interest due.

Debarment

Any contractor or subcontractor and/or its successor shall be ineligible to submit a bid on or be awarded any public work contract or subcontract with any state, municipal corporation or public body for a period of five (5) years when:

- Two (2) willful determinations have been rendered against that contractor or subcontractor and/or its successor within any consecutive six (6) year period.
- There is any willful determination that involves the falsification of payroll records or the kickback of wages or supplements.

Criminal Sanctions

Willful violations of the Prevailing Wage Law (Article 8 of the Labor Law) may be a felony punishable by fine or imprisonment of up to 15 years, or both.

Discrimination

No employee or applicant for employment may be discriminated against on account of age, race, creed, color, national origin, sex, disability or marital status.

No contractor, subcontractor nor any person acting on its behalf, shall by reason of race, creed, color, disability, sex or national origin discriminate against any citizen of the State of New York who is qualified and available to perform the work to which the employment relates (NYS Labor Law, Article 8, Section 220-e(a)).

No contractor, subcontractor, nor any person acting on its behalf, shall in any manner, discriminate against or intimidate any employee on account of race, creed, color, disability, sex, or national origin (NYS Labor Law, Article 8, Section 220-

e(b)).

The Human Rights Law also prohibits discrimination in employment because of age, marital status, or religion.

There may be deducted from the amount payable to the contractor under the contract a penalty of \$50.00 for each calendar day during which such person was discriminated against or intimidated in violation of the provision of the contract (NYS Labor Law, Article 8, Section 220-e(c)).

The contract may be cancelled or terminated by the State or municipality. All monies due or to become due thereunder may be forfeited for a second or any subsequent violation of the terms or conditions of the anti-discrimination sections of the contract (NYS Labor Law, Article 8, Section 220-e(d)).

Every employer subject to the New York State Human Rights Law must conspicuously post at its offices, places of employment, or employment training centers notices furnished by the State Division of Human Rights.

Workers' Compensation

In accordance with Section 142 of the State Finance Law, the contractor shall maintain coverage during the life of the contract for the benefit of such employees as required by the provisions of the New York State Workers' Compensation Law.

A contractor who is awarded a public work contract must provide proof of workers' compensation coverage prior to being allowed to begin work.

The insurance policy must be issued by a company authorized to provide workers' compensation coverage in New York State. Proof of coverage must be on form C-105.2 (Certificate of Workers' Compensation Insurance) and must name this agency as a certificate holder.

If New York State coverage is added to an existing out-of-state policy, it can only be added to a policy from a company authorized to write workers' compensation coverage in this state. The coverage must be listed under item 3A of the information page.

The contractor must maintain proof that subcontractors doing work covered under this contract secured and maintained a workers' compensation policy for all employees working in New York State.

Every employer providing worker's compensation insurance and disability benefits must post notices of such coverage in the format prescribed by the Workers' Compensation Board in a conspicuous place on the jobsite.

Unemployment Insurance

Employers liable for contributions under the Unemployment Insurance Law must conspicuously post on the jobsite notices furnished by the New York State Department of Labor.



Andrew M. Cuomo, Governor

Roberta Reardon, Commissioner

Cattaraugus County DPW
Glenn Blake
403 Main Street, Suite 330
Buffalo NY 14203

Schedule Year 2019 through 2020
Date Requested 11/22/2019
PRC# 2019014891

Location Various locations
Project ID#
Project Type Painting 3 roadway bridges

Notice of Contract Award

New York State Labor Law, Article 8, Section 220.3a requires that certain information regarding the awarding of public work contracts, be furnished to the Commissioner of Labor. One "Notice of Contract Award" (PW 16, which may be photocopied), **MUST** be completed for **EACH** prime contractor on the above referenced project.

Upon notifying the successful bidder(s) of this contract, enter the required information and mail **OR** fax this form to the office shown at the bottom of this notice, **OR** fill out the electronic version via the NYSDOL website.

Contractor Information

All information must be supplied

Federal Employer Identification Number: _____		
Name: _____		
Address: _____ _____		
City: _____	State: _____	Zip: _____
Amount of Contract: \$ _____	Contract Type:	
Approximate Starting Date: ____/____/____	<input type="checkbox"/> (01) General Construction	
Approximate Completion Date: ____/____/____	<input type="checkbox"/> (02) Heating/Ventilation	
	<input type="checkbox"/> (03) Electrical	
	<input type="checkbox"/> (04) Plumbing	
	<input type="checkbox"/> (05) Other : _____	

Phone: (518) 457-5589 Fax: (518) 485-1870
W. Averell Harriman State Office Campus, Bldg. 12, Room 130, Albany, NY 12240

IMPORTANT NOTICE

FOR

CONTRACTORS & CONTRACTING AGENCIES

Social Security Numbers on Certified Payrolls

The Department of Labor is cognizant of the concerns of the potential for misuse or inadvertent disclosure of social security numbers. Identity theft is a growing problem and we are sympathetic to contractors' concerns with regard to inclusion of this information on payrolls if another identifier will suffice.

For these reasons, *the substitution of the use of the last four digits of the social security number on certified payrolls submitted to contracting agencies on public work projects is now acceptable to the Department of Labor.*

NOTE: This change does not affect the Department's ability to request and receive the entire social security number from employers during the course of its public work / prevailing wage investigations.

**To all State Departments, Agency Heads and Public Benefit Corporations
IMPORTANT NOTICE REGARDING PUBLIC WORK ENFORCEMENT FUND**

Budget Policy & Reporting Manual

B-610

Public Work Enforcement Fund

effective date December 7, 2005

1. Purpose and Scope:

This Item describes the Public Work Enforcement Fund (the Fund, PWEF) and its relevance to State agencies and public benefit corporations engaged in construction or reconstruction contracts, maintenance and repair, and announces the recently-enacted increase to the percentage of the dollar value of such contracts that must be deposited into the Fund. This item also describes the roles of the following entities with respect to the Fund:

- New York State Department of Labor (DOL),
- The Office of the State of Comptroller (OSC), and
- State agencies and public benefit corporations.

2. Background and Statutory References:

DOL uses the Fund to enforce the State's Labor Law as it relates to contracts for construction or reconstruction, maintenance and repair, as defined in subdivision two of Section 220 of the Labor Law. State agencies and public benefit corporations participating in such contracts are required to make payments to the Fund.

Chapter 511 of the Laws of 1995 (as amended by Chapter 513 of the Laws of 1997, Chapter 655 of the Laws of 1999, Chapter 376 of the Laws of 2003 and Chapter 407 of the Laws of 2005) established the Fund.

3. Procedures and Agency Responsibilities:

The Fund is supported by transfers and deposits based on the value of contracts for construction and reconstruction, maintenance and repair, as defined in subdivision two of Section 220 of the Labor Law, into which all State agencies and public benefit corporations enter.

Chapter 407 of the Laws of 2005 increased the amount required to be provided to this fund to .10 of one-percent of the total cost of each such contract, to be calculated at the time agencies or public benefit corporations enter into a new contract or if a contract is amended. The provisions of this bill became effective August 2, 2005.

**To all State Departments, Agency Heads and Public Benefit Corporations
IMPORTANT NOTICE REGARDING PUBLIC WORK ENFORCEMENT FUND**

OSC will report to DOL on all construction-related ("D") contracts approved during the month, including contract amendments, and then DOL will bill agencies the appropriate assessment monthly. An agency may then make a determination if any of the billed contracts are exempt and so note on the bill submitted back to DOL. For any instance where an agency is unsure if a contract is or is not exempt, they can call the Bureau of Public Work at the number noted below for a determination. Payment by check or journal voucher is due to DOL within thirty days from the date of the billing. DOL will verify the amounts and forward them to OSC for processing.

For those contracts which are not approved or administered by the Comptroller, monthly reports and payments for deposit into the Public Work Enforcement Fund must be provided to the Administrative Finance Bureau at the DOL within 30 days of the end of each month or on a payment schedule mutually agreed upon with DOL.

Reports should contain the following information:

- Name and billing address of State agency or public benefit corporation;
- State agency or public benefit corporation contact and phone number;
- Name and address of contractor receiving the award;
- Contract number and effective dates;
- Contract amount and PWEF assessment charge (if contract amount has been amended, reflect increase or decrease to original contract and the adjustment in the PWEF charge); and
- Brief description of the work to be performed under each contract.

Checks and Journal Vouchers, payable to the "New York State Department of Labor" should be sent to:

Department of Labor
Administrative Finance Bureau-PWEF Unit
Building 12, Room 464
State Office Campus
Albany, NY 12240

Any questions regarding billing should be directed to NYSDOL's Administrative Finance Bureau-PWEF Unit at (518) 457-3624 and any questions regarding Public Work Contracts should be directed to the Bureau of Public Work at (518) 457-5589.

Construction Industry Fair Play Act

Required Posting For Labor Law Article 25-B § 861-d

Construction industry employers must post the "Construction Industry Fair Play Act" notice in a prominent and accessible place on the job site.

Failure to post the notice can result in penalties of up to \$1,500 for a first offense and up to \$5,000 for a second offense.

The posting is included as part of this wage schedule. Additional copies may be obtained from the NYS DOL website, www.labor.ny.gov.

If you have any questions concerning the Fair Play Act, please call the State Labor Department toll-free at 1-866-435-1499 or email us at: dol.misclassified@labor.state.ny.us .

Required Notice under Article 25-B of the Labor Law

**Attention All Employees, Contractors and Subcontractors:
You are Covered by the Construction Industry Fair Play Act**

The law says that you are an employee unless:

- You are free from direction and control in performing your job, **and**
- You perform work that is not part of the usual work done by the business that hired you, **and**
- You have an independently established business.

Your employer cannot consider you to be an independent contractor unless all three of these facts apply to your work.

It is against the law for an employer to misclassify employees as independent contractors or pay employees off the books.

Employee Rights: If you are an employee, you are entitled to state and federal worker protections. These include:

- Unemployment Insurance benefits, if you are unemployed through no fault of your own, able to work, and otherwise qualified,
- Workers' compensation benefits for on-the-job injuries,
- Payment for wages earned, minimum wage, and overtime (under certain conditions),
- Prevailing wages on public work projects,
- The provisions of the National Labor Relations Act, and
- A safe work environment.

It is a violation of this law for employers to retaliate against anyone who asserts their rights under the law. Retaliation subjects an employer to civil penalties, a private lawsuit or both.

Independent Contractors: If you are an independent contractor, **you must pay all taxes and Unemployment Insurance contributions required by New York State and Federal Law.**

Penalties for paying workers off the books or improperly treating employees as independent contractors:

- **Civil Penalty** First offense: Up to \$2,500 per employee
 Subsequent offense(s): Up to \$5,000 per employee
- **Criminal Penalty** First offense: Misdemeanor - up to 30 days in jail, up to a \$25,000 fine and debarment from performing public work for up to one year.
 Subsequent offense(s): Misdemeanor - up to 60 days in jail or up to a \$50,000 fine and debarment from performing public work for up to 5 years.

If you have questions about your employment status or believe that your employer may have violated your rights and you want to file a complaint, call the Department of Labor at (866) 435-1499 or send an email to dol.misclassified@labor.ny.gov. All complaints of fraud and violations are taken seriously. You can remain anonymous.

Employer Name:

IA 999 (09/16)

WORKER NOTIFICATION

(Labor Law §220, paragraph a of subdivision 3-a)

Effective February 24, 2008

This provision is an addition to the existing prevailing wage rate law, Labor Law §220, paragraph a of subdivision 3-a. It requires contractors and subcontractors to provide written notice to all laborers, workers or mechanics of the *prevailing wage rate* for their particular job classification *on each pay stub**. It also requires contractors and subcontractors to *post a notice* at the beginning of the performance of every public work contract *on each job site* that includes the telephone number and address for the Department of Labor and a statement informing laborers, workers or mechanics of their right to contact the Department of Labor if he/she is not receiving the proper prevailing rate of wages and/or supplements for his/her particular job classification. The required notification will be provided with each wage schedule, may be downloaded from our website www.labor.ny.gov or made available upon request by contacting the Bureau of Public Work at 518-457-5589.

* In the event that the required information will not fit on the pay stub, an accompanying sheet or attachment of the information will suffice.

Attention Employees

THIS IS A: **PUBLIC WORK PROJECT**

If you are employed on this project as a **worker, laborer, or mechanic** you are entitled to receive the **prevailing wage and supplements rate** for the classification at which you are working.

Chapter 629 of the Labor Laws of 2007:

These wages are set by law and must be posted at the work site. They can also be found at:
www.labor.ny.gov

If you feel that you have not received proper wages or benefits, please call our nearest office.*

Albany	(518) 457-2744	Patchogue	(631) 687-4882
Binghamton	(607) 721-8005	Rochester	(585) 258-4505
Buffalo	(716) 847-7159	Syracuse	(315) 428-4056
Garden City	(516) 228-3915	Utica	(315) 793-2314
New York City	(212) 932-2419	White Plains	(914) 997-9507
Newburgh	(845) 568-5156		

* For New York City government agency construction projects, please contact the Office of the NYC Comptroller at (212) 669-4443, or www.comptroller.nyc.gov – click on Bureau of Labor Law.

Contractor Name: _____

Project Location: _____

OSHA 10-hour Construction Safety and Health Course – S1537-A

Effective July 18, 2008

This provision is an addition to the existing prevailing wage rate law, Labor Law §220, section 220-h. It requires that on all public work projects of at least \$250,000.00, all laborers, workers and mechanics working on the site, be certified as having successfully completed the OSHA 10-hour construction safety and health course. It further requires that the advertised bids and contracts for every public work contract of at least \$250,000.00, contain a provision of this requirement.

NOTE: The OSHA 10 Legislation only applies to workers on a public work project that are required, under Article 8, to receive the prevailing wage.

Where to find OSHA 10-hour Construction Course

1. NYS Department of Labor website for scheduled outreach training at:

https://labor.ny.gov/workerprotection/safetyhealth/dosh_training.shtm

2. OSHA Training Institute Education Centers:

Rochester Institute of Technology OSHA Education Center

Rochester, NY

Donna Winter

Fax (585) 475-6292

e-mail: dlwtpo@rit.edu

(866) 385-7470 Ext. 2919

www.rit.edu/~outreach/course.php3?CourseID=54

Atlantic OSHA Training Center

UMDNJ – School of Public Health

Piscataway, NJ

Janet Crooks

Fax (732) 235-9460

e-mail: crooksje@umdnj.edu

(732) 235-9455

<https://ophp.umdnj.edu/wconnect/ShowSchedule.awp?~~GROUP~AOTCON~10~>

Atlantic OSHA Training Center

University at Buffalo

Buffalo, New York

Joe Syracuse

Fax (716) 829-2806

e-mail: mailto:japs@buffalo.edu

(716) 829-2125

http://www.smbs.buffalo.edu/CENTERS/trc/schedule_OSHA.php

Keene State College

Manchester, NH

Leslie Singleton

e-mail: lsingletin@keene.edu

(800) 449-6742

www.keene.edu/courses/print/courses_osa.cfm

3. List of trainers and training schedules for OSHA outreach training at:

www.OutreachTrainers.org

Requirements for OSHA 10 Compliance

Chapter 282 of the Laws of 2007, codified as Labor Law 220-h took effect on July 18, 2008. The statute provides as follows:

The advertised specifications for every contract for public work of \$250,000.00 or more must contain a provision requiring that every worker employed in the performance of a public work contract shall be certified as having completed an OSHA 10 safety training course. The clear intent of this provision is to require that all employees of public work contractors, required to be paid prevailing rates, receive such training “prior to the performing any work on the project.”

The Bureau will enforce the statute as follows:

All contractors and sub contractors must attach a copy of proof of completion of the OSHA 10 course to the first certified payroll submitted to the contracting agency and on each succeeding payroll where any new or additional employee is first listed.

Proof of completion may include but is not limited to:

- Copies of bona fide course completion card (*Note: Completion cards do not have an expiration date.*)
- Training roster, attendance record of other documentation from the certified trainer pending the issuance of the card.
- Other valid proof

**A certification by the employer attesting that all employees have completed such a course is not sufficient proof that the course has been completed.

Any questions regarding this statute may be directed to the New York State Department of Labor, Bureau of Public Work at 518-485-5696.

WICKS Reform 2008

(For all contracts advertised or solicited for bid on or after 7/1/08)

- Raises the threshold for public work projects subject to the Wicks Law requiring separate specifications and bidding for the plumbing, heating and electrical work. The total project's threshold would increase from \$50,000 to: \$3 million in Bronx, Kings, New York, Queens and Richmond counties; \$1.5 million in Nassau, Suffolk and Westchester counties; and \$500,000 in all other counties.
- For projects below the monetary threshold, bidders must submit a sealed list naming each subcontractor for the plumbing, HVAC and electrical work and the amount to be paid to each. The list may not be changed unless the public owner finds a legitimate construction need, including a change in specifications or costs or use of a Project Labor Agreement (PLA), and must be open to public inspection.
- Allows the state and local agencies and authorities to waive the Wicks Law and use a PLA if it will provide the best work at the lowest possible price. If a PLA is used, all contractors shall participate in apprentice training programs in the trades of work it employs that have been approved by the Department of Labor (DOL) for not less than three years. They shall also have at least one graduate in the last three years and use affirmative efforts to retain minority apprentices. PLA's would be exempt from Wicks, but deemed to be public work subject to prevailing wage enforcement.
- The Commissioner of Labor shall have the power to enforce separate specification requirements on projects, and may issue stop-bid orders against public owners for non-compliance.
- Other new monetary thresholds, and similar sealed bidding for non-Wicks projects, would apply to certain public authorities including municipal housing authorities, NYC Construction Fund, Yonkers Educational Construction Fund, NYC Municipal Water Finance Authority, Buffalo Municipal Water Finance Authority, Westchester County Health Care Association, Nassau County Health Care Corp., Clifton-Fine Health Care Corp., Erie County Medical Center Corp., NYC Solid Waste Management Facilities, and the Dormitory Authority.
- Reduces from 15 to 7 days the period in which contractors must pay subcontractors.

IMPORTANT INFORMATION

**Regarding Use of Form PW30.1
(Previously 30R)**

“Employer Registration for Use of 4 Day / 10 Hour Work Schedule”

To use the ‘4 Day / 10 Hour Work Schedule’:

There **MUST** be a *Dispensation of Hours (PW30)* in place on the project

AND

You **MUST** register your intent to work 4 / 10 hour days, by completing the PW30.1 Form.

REMEMBER...

The ‘4 Day / 10 Hour Work Schedule’ applies **ONLY** to Job Classifications and Counties listed on the PW30.1 Form.

Do not write in any additional Classifications or Counties.

(Please note : For each Job Classification check the individual wage schedule for specific details regarding their 4/10 hour day posting.)

Instructions for Completing Form PW30.1

(Previously 30R)

“Employer Registration for Use of 4 Day / 10 Hour Work Schedule”

Before completing Form PW30.1 check to be sure ...

- There is a *Dispensation of Hours* in place on the project.
- The 4 Day / 10 Hour Work Schedule applies to the Job Classifications you will be using.
- The 4 Day / 10 Hour Work Schedule applies to the County / Counties where the work will take place.

Instructions (Type or Print legibly):

Contractor Information:

- Enter the Legal Name of the business, FEIN, Street Address, City, State, Zip Code; the Company’s Phone and Fax numbers; and the Company’s email address (if applicable)
- Enter the Name of a Contact Person for the Company along with their Phone and Fax numbers, and the personal email address (if applicable)

Project Information:

- Enter the Prevailing Rate Case number (PRC#) assigned to this project
- Enter the Project Name / Type (i.e. Smithtown CSD – Replacement of HS Roof)
- Enter the Exact Location of Project (i.e. Smithtown HS, 143 County Route #2, Smithtown,NY; Bldgs. 1 & 2)
- If you are a Subcontractor, enter the name of the Prime Contractor for which you work
- On the Checklist of Job Classifications -
 - Go to pages 2 and 3 of the form
 - Place a checkmark in the box to the right of the Job Classification you are choosing
 - Mark all Job Classifications that apply

****Do not write in any additional Classifications or Counties.****

Requestor Information:

- Enter the name of the person submitting the registration, their title with the company , and the date the registration is filled out

Return Completed Form:

- **Mail** the completed PW30.1 form to: NYSDOL Bureau of Public Work, SOBC – Bldg.12 – Rm.130, Albany, NY 12240 **-OR-**
- **Fax** the completed PW30.1 form to: NYSDOL Bureau of Public Work at (518)485-1870



Bureau of Public Work Harriman
State Office Campus
Building 12, Room 130
Albany, New York 12240
Phone: (518) 457-5589 | Fax: (518) 485-1870
www.labor.ny.gov

Employer Registration for Use of 4 Day / 10 Hour Work Schedule

Before completing this form, make sure that:

- There is a **Dispensation of Hours** in place on the project.
- The 4 Day / 10 Hour Work Schedule applies to the Job Classifications you will be using.
- The 4 Day / 10 Hour Work Schedule applies to the County / Counties where the work will take place.

Please **type or print** the requested information and then **mail or fax** to the address above.

Contractor Information

Company Name: _____ FEIN: _____

Address: _____

City: _____ State: _____ Zip Code: _____

Phone No: _____ Fax No: _____ Email: _____

Contact Person: _____

Phone No: _____ Fax No: _____ Email: _____

Project Information

Project PRC#: _____ Project Name/Type: _____

Exact Location
of Project: _____ County: _____

(If you are Subcontractor)

Prime Contractor Name: _____

Job Classification(s) to Work 4/10 Schedule: *(Choose all that apply on Job Classification Checklist - Pages 3-8)*
**** Do not write in any additional Classifications or Counties****

Requestor Information

Name: _____

Title: _____ Date: _____

Please use the list below with the number assigned to each county as a reference to the corresponding numbers listed in the following pages under **Entire Counties & Partial Counties**.

- | | | | |
|-----|-----------------------------|-----|---------------------------------|
| 1. | Albany County | 33. | Oneida County |
| 2. | Allegany County | 34. | Onondaga County |
| 3. | Bronx County | 35. | Ontario County |
| 4. | Broome County | 36. | Orange County |
| 5. | Cattaraugus County | 37. | Orleans County |
| 6. | Cayuga County | 38. | Oswego County |
| 7. | Chautauqua County | 39. | Otsego County |
| 8. | Chemung County | 40. | Putnam County |
| 9. | Chenango County | 41. | Queens County |
| 10. | Clinton County | 42. | Rensselaer County |
| 11. | Columbia County | 43. | Richmond County (Staten Island) |
| 12. | Cortland County | 44. | Rockland County |
| 13. | Delaware County | 45. | Saint Lawrence County |
| 14. | Dutchess County | 46. | Saratoga County |
| 15. | Erie County | 47. | Schenectady County |
| 16. | Essex County | 48. | Schoharie County |
| 17. | Franklin County | 49. | Schuyler County |
| 18. | Fulton County | 50. | Seneca County |
| 19. | Genesee County | 51. | Steuben County |
| 20. | Greene County | 52. | Suffolk County |
| 21. | Hamilton County | 53. | Sullivan County |
| 22. | Herkimer County | 54. | Tioga County |
| 23. | Jefferson County | 55. | Tompkins County |
| 24. | Kings County (Brooklyn) | 56. | Ulster County |
| 25. | Lewis County | 57. | Warren County |
| 26. | Livingston County | 58. | Washington County |
| 27. | Madison County | 59. | Wayne County |
| 28. | Monroe County | 60. | Westchester County |
| 29. | Montgomery County | 61. | Wyoming County |
| 30. | Nassau County | 62. | Yates County |
| 31. | New York County (Manhattan) | | |
| 32. | Niagara County | | |

Job Classification Checklist

(Place a checkmark by all classifications that will be using the 4/10 schedule)

**** Do not write in any additional Classifications or Counties****

Job Classification	Tag #	Entire Counties	Partial Counties	Check Box
Carpenter – Building	276B-All	7	2 ,5	
Carpenter – Building	276B-Cat	15	5	
Carpenter – Building	276-B-LIV	26, 28, 35, 59	61	
Carpenter – Building	276B-Gen	19, 32, 37	61	
Carpenter – Heavy & Highway	276HH-All	2, 5, 7		
Carpenter – Heavy & Highway	276HH-Erie	15		
Carpenter – Heavy & Highway	276HH- Gen	19, 32, 37, 61		
Carpenter – Heavy & Highway	276HH-Liv	26, 28, 35, 59		
Carpenter – Residential	276R-All	7	2, 5	
Carpenter – Building	277B-Bro	4, 54		
Carpenter – Building	277B-CAY	6, 50, 62		
Carpenter – Building	277B-CS	8, 12, 49, 51, 55	2	
Carpenter – Building	277 JLS	23, 25, 45		
Carpenter – Building	277 omh	22, 27, 33		
Carpenter – Building	277 On	34		
Carpenter – Building	277 Os	38		
Carpenter – Building	277CDO Bldg	9, 13, 39		
Carpenter – Heavy & Highway	277CDO HH	9, 13, 39		
Carpenter – Heavy & Highway	277HH-BRO	4, 6, 8, 12, ,22, 23, 25, 27, 33, 34, 38, 45, 49, 50, 51, 54, 55, 62		
Carpenter – Building	291B-Alb	1, 18, 20, 29, 42, 47, 48		
Carpenter – Building	291B-Cli	10, 16, 17		
Carpenter – Building	291B-Ham	21, 57, 58		
Carpenter – Building	291B-Sar	46		
Carpenter – Heavy & Highway	291HH-Alb	1, 10, 16, 17,18, 20, 21, 29, 42, 46, 47, 48, 57, 58		
Electrician	25m	30, 52		
Electrician – Teledata Cable Splicer	43	12, 22, 27, 33, 38	6, 9, 34, 39, 55, 59	

Job Classification Checklist

(Place a checkmark by all classifications that will be using the 4/10 schedule)

**** Do not write in any additional Classifications or Counties****

Job Classification	Tag #	Entire Counties	Partial Counties	Check Box
Electrician	86	26, 28	19, 35, 37, 59, 61	
Electrician	840 Teledata and 840 Z1	62	6, 34, 35, 50, 59	
Electrician	910	10, 16, 17, 23, 25, 45		
Electrical Lineman	1049Line/Gas	30, 41, 52		
Electrical Lineman	1249a	1, 2, 4, 5, 6, 7, 8, 9, 10, 11, 12, 13, 14, 15, 16, 17, 18, 19, 20, 21, 22, 23, 25, 26, 27, 28, 29, 32, 33, 34, 35, 36, 37, 38, 39, 40, 42, 44, 46, 47, 48, 49, 50, 45, 51, 53, 54, 55, 56, 57, 58, 59, 61, 62		
Electrical Lineman	1249a West	60		
Electrical Lineman	1249a-LT	1, 2, 4, 5, 6, 7, 8, 9, 10, 12, 13, 15, 16, 17, 18, 19, 20, 21, 22, 23, 25, 26, 27, 28, 29, 32, 33, 34, 35, 37, 38, 39, 42, 46, 47, 48, 49, 50, 45, 51, 53, 54, 55, 57, 58, 59, 61, 62		
Electrical Lineman	1249aREG8LT	11, 14, 36, 40, 44, 56		
Electrical Lineman	1249aWestLT	60		
Elevator Constructor	138	11, 14, 20, 36, 40, 53, 56	13, 44, 60	
Elevator Constructor	14	2, 5, 7, 15, 19, 32, 37, 61		
Elevator Constructor	27	8, 26, 28, 35, 49, 50, 51, 59, 62		
Elevator Constructor	35	1, 10, 16, 18, 21, 22, 29, 39, 42, 46, 47, 48, 57, 58		
Elevator Constructor	62.1	4, 6, 9, 12, 23, 25, 27, 33, 34, 38, 45, 54, 55	13	
Glazier	201	1, 10, 11, 16, 17, 18, 20, 21, 29, 42, 46, 47, 48, 57, 58		
Glazier	660r	2, 5, 7, 15, 19, 32, 37, 61		
Glazier	660	2, 5, 7, 15, 19, 32, 37, 61		
Glazier	677.1	23, 25, 26, 28, 35, 45, 50, 59, 62		
Glazier	677Z-2	6, 12, 22, 27, 33, 34, 38		
Glazier	677z3	4, 8, 9, 13, 39, 49, 51, 54, 55		
Glazier	677r.2	6, 12, 22, 27, 33, 34, 38		
Insulator – Heat & Frost	30-Syracuse	4, 6, 8, 9, 12, 22, 23, 25, 27, 33, 34, 38, 39, 49, 50, 45, 54, 55		
Laborer – Building	621b	2, 7	5	
Laborer – Building	633 bON	34		

Job Classification Checklist

(Place a checkmark by all classifications that will be using the 4/10 schedule)

*** Do not write in any additional Classifications or Counties***

Job Classification	Tag #	Entire Counties	Partial Counties	Check Box
Laborer – Building	633b Cay	6		
Laborer – Building	633bOS	38		
Laborer – Building	785(7)	4	9, 13, 54	
Laborer – Building	785B-CS	8, 51	49	
Laborer – Building	7-785b	12, 55	49, 54	
Laborers – Heavy & Highway	157h/h	47	18, 29, 46	
Laborers – Heavy & Highway	190 h/h	1, 42, 58	11, 20, 46	
Laborers – Heavy & Highway	35/2h	21, 22, 27, 33	18, 29	
Laborer – Residential	621r	2, 7	5	
Laborers – Tunnel	157	47	18, 29, 46	
Laborers – Tunnel	35T	21, 22, 27, 33	18, 29	
Laborers – Tunnel	190	1, 42, 58	11, 20, 46	
Mason – Building	2TS.1	1, 10,11, 16, 17, 18, 20, 21, 29, 42, 46, 47, 48, 57, 58		
Mason – Building	2TS.2	22, 23, 25, 33, 45	27	
Mason – Building	2TS.3	6, 34, 38	27	
Mason – Building	2b-on	34		
Mason – Building	2b.1	1, 11, 18, 20, 21, 29, 42, 46, 47, 48, 58	57	
Mason – Building	2b.2	22, 33	25	
Mason – Building	2b.3	6, 34	27	
Mason – Building	2b.4	38		
Mason – Building	2b.5	23	25	
Mason – Building	2b.6	45		
Mason – Building	2b.8	10, 16, 17	57	
Mason – Building	3b-Co-Z2	8, 49, 51	2	
Mason – Building	3B-Z1	19, 26, 28, 35, 50, 59, 61, 62		
Mason – Building – Residential	3B-Z1R	19, 26, 28, 35, 50, 59, 61, 62		
Mason – Building	3B-Bing-Z2	4, 9, 13, 39, 54		
Mason – Building	3B-lth-Z2	12, 55		

Job Classification Checklist

(Place a checkmark by all classifications that will be using the 4/10 schedule)

*** Do not write in any additional Classifications or Counties***

Job Classification	Tag #	Entire Counties	Partial Counties	Check Box
Mason – Building	3B-Jam-Z2	7	2, 5	
Mason – Building – Residential	3B-Jam-Z2R	2, 4, 8, 7, 9, 12, 39, 13, 49, 51, 54, 55	5	
Mason – Building	3B-Z3	15, 32	5	
Mason – Building	3B-Z3.Orleans	37		
Mason – Residential	3B-Z3R	15, 32	5	
Mason – Residential	3B-z3R.Orleans	37		
Mason - Heavy & Highway	3h	2, 4, 8, 7, 9, 12, 13, 19, 26, 28, 35, 37, 39, 49, 50, 51, 54, 55, 59, 61, 62	5, 15, 32	
Mason – Tile Finisher	3TF-Z1	19, 26, 28, 35, 50, 59, 61, 62		
Mason – Tile Finisher	3TF-Z2	2, 4, 8, 7, 9, 12, 13, 39, 49, 51, 54, 55	5	
Mason – Tile Finisher	3TF-Z3	15, 32, 37	5	
Mason – Tile Finisher	3TF-Z1R	19, 26, 28, 35, 50, 59, 61, 62		
Mason – Tile Finisher	3TF-Z2R	2, 4, 7, 9, 12, 13, 39, 49, 51, 54, 55	5	
Mason – Tile Finisher	3TF-Z3R	15, 32, 37	5	
Mason – Tile Setter	3TS-Z1	19, 26, 28, 35, 50, 59, 61, 62		
Mason – Tile Setter Residential	3TS-Z1R	19, 26, 28, 35, 50, 59, 61, 62		
Mason – Tile Setter	3TS-Z2	2, 4, 7, 8, 9, 12, 13, 39, 49, 51, 54, 55	5	
Mason – Tile Setter Residential	3TS-Z2R	2, 4, 7, 8, 9, 12, 13, 39, 49, 51, 54, 55	5	
Mason – Tile Setter	3TS-Z3	15, 32, 37	5	
Mason – Tile Setter Residential	3TS-Z3R	15, 32, 37	5	
Mason – Building/Heavy & Highway	780	3, 24, 30, 31, 41, 43, 52		
Operating Engineer - Heavy & Highway	137H/H	40, 60	14	
Operating Engineer – Heavy & Highway	158-832H	2, 8, 26, 28, 35, 49, 51, 59, 62	19	
Operating Engineer – Heavy & Highway	158-H/H	1, 4, 9, 10, 11, 14, 16, 17, 18, 20, 21, 22, 29, 39, 42, 46, 47, 48, 54, 57, 58		
Operating Engineer – Heavy & Highway	158-545h	6, 12, 23, 25, 27, 33, 38, 45, 50, 55		
Painter	1456-LS	1, 3, 10, 11, 14, 16, 17, 18, 20, 21, 24, 29, 30, 31, 36, 40, 41, 42, 43, 44, 46, 47, 48, 52, 53, 56, 57, 58, 60		
Painter	150	28, 59, 62	26, 35	

Job Classification Checklist

(Place a checkmark by all classifications that will be using the 4/10 schedule)

*** Do not write in any additional Classifications or Counties***

Job Classification	Tag #	Entire Counties	Partial Counties	Check Box
Painter	178 B	4, 9, 54		
Painter	178 E	8, 49	51	
Painter	178 I	12, 55		
Painter	178 O	13, 39		
Painter	31	6, 22, 27, 33, 34, 50	25, 35, 38	
Painter	38.O		38	
Painter	38.W	23, 45	25	
Painter	4- Buf,Nia,Olean	2, 15, 19, 32, 37, 61	5, 7, 26, 51	
Painter	4-Jamestown		5, 7	
Sheetmetal Worker	46	26, 28, 35, 50, 59, 62		
Sheetmetal Worker	46r	26, 28, 35, 50, 59, 62		
Teamsters – Heavy & Highway	294h/h	1, 11, 18, 20, 29, 42, 46, 47, 48, 58	57	
Teamsters – Heavy & Highway	317bhh	6, 12, 50, 51, 55, 62	2	
Teamsters - Building/Heavy & Highway	456	40, 60		

Introduction to the Prevailing Rate Schedule

Information About Prevailing Rate Schedule

This information is provided to assist you in the interpretation of particular requirements for each classification of worker contained in the attached Schedule of Prevailing Rates.

Classification

It is the duty of the Commissioner of Labor to make the proper classification of workers taking into account whether the work is heavy and highway, building, sewer and water, tunnel work, or residential, and to make a determination of wages and supplements to be paid or provided. It is the responsibility of the public work contractor to use the proper rate. If there is a question on the proper classification to be used, please call the district office located nearest the project. District office locations and phone numbers are listed below.

Prevailing Wage Schedules are issued separately for "General Construction Projects" and "Residential Construction Projects" on a county-by-county basis.

General Construction Rates apply to projects such as: Buildings, Heavy & Highway, and Tunnel and Water & Sewer rates.

Residential Construction Rates generally apply to construction, reconstruction, repair, alteration, or demolition of one family, two family, row housing, or rental type units intended for residential use.

Some rates listed in the Residential Construction Rate Schedule have a very limited applicability listed along with the rate. Rates for occupations or locations not shown on the residential schedule must be obtained from the General Construction Rate Schedule. Please contact the local Bureau of Public Work office before using Residential Rate Schedules, to ensure that the project meets the required criteria.

Payrolls and Payroll Records

Contractors and subcontractors are required to establish, maintain, and preserve for not less than six (6) years, contemporaneous, true, and accurate payroll records.

Every contractor and subcontractor shall submit to the Department of Jurisdiction (Contracting Agency), within thirty (30) days after issuance of its first payroll and every thirty (30) days thereafter, a transcript of the original payrolls, subscribed and affirmed as true under penalty of perjury.

Paid Holidays

Paid Holidays are days for which an eligible employee receives a regular day's pay, but is not required to perform work. If an employee works on a day listed as a paid holiday, this remuneration is in addition to payment of the required prevailing rate for the work actually performed.

Overtime

At a minimum, all work performed on a public work project in excess of eight hours in any one day or more than five days in any workweek is overtime. However, the specific overtime requirements for each trade or occupation on a public work project may differ. Specific overtime requirements for each trade or occupation are contained in the prevailing rate schedules.

Overtime holiday pay is the premium pay that is required for work performed on specified holidays. It is only required where the employee actually performs work on such holidays.

The applicable holidays are listed under HOLIDAYS: OVERTIME. The required rate of pay for these covered holidays can be found in the OVERTIME PAY section listings for each classification.

Supplemental Benefits

Particular attention should be given to the supplemental benefit requirements. Although in most cases the payment or provision of supplements is straight time for all hours worked, some classifications require the payment or provision of supplements, or a portion of the supplements, to be paid or provided at a premium rate for premium hours worked. Supplements may also be required to be paid or provided on paid holidays, regardless of whether the day is worked. The Overtime Codes and Notes listed on the particular wage classification will indicate these conditions as required.

Effective Dates

When you review the schedule for a particular occupation, your attention should be directed to the dates above the column of rates. These are the dates for which a given set of rates is effective. The rate listed is valid until the next effective rate change or until the new annual determination which takes effect on July 1 of each year. All contractors and subcontractors are required to pay the current prevailing rates of wages and supplements. If you have any questions please contact the Bureau of Public Work or visit the New York State Department of Labor website (www.labor.ny.gov) for current wage rate information.

Apprentice Training Ratios

The following are the allowable ratios of registered Apprentices to Journey-workers.

For example, the ratio 1:1,1:3 indicates the allowable initial ratio is one Apprentice to one Journeyworker. The Journeyworker must be in place on the project before an Apprentice is allowed. Then three additional Journeyworkers are needed before a second Apprentice is allowed. The last ratio repeats indefinitely. Therefore, three more Journeyworkers must be present before a third Apprentice can be hired, and so on.

Please call Apprentice Training Central Office at (518) 457-6820 if you have any questions.

Title (Trade)	Ratio
Boilermaker (Construction)	1:1,1:4
Boilermaker (Shop)	1:1,1:3
Carpenter (Bldg.,H&H, Pile Driver/Dockbuilder)	1:1,1:4
Carpenter (Residential)	1:1,1:3
Electrical (Outside) Lineman	1:1,1:2
Electrician (Inside)	1:1,1:3
Elevator/Escalator Construction & Modernizer	1:1,1:2
Glazier	1:1,1:3
Insulation & Asbestos Worker	1:1,1:3
Iron Worker	1:1,1:4
Laborer	1:1,1:3
Mason	1:1,1:4
Millwright	1:1,1:4
Op Engineer	1:1,1:5
Painter	1:1,1:3
Plumber & Steamfitter	1:1,1:3
Roofer	1:1,1:2
Sheet Metal Worker	1:1,1:3
Sprinkler Fitter	1:1,1:2

If you have any questions concerning the attached schedule or would like additional information, please contact the nearest BUREAU of PUBLIC WORK District Office or write to:

New York State Department of Labor
Bureau of Public Work
State Office Campus, Bldg. 12
Albany, NY 12240

District Office Locations:	Telephone #	FAX #
Bureau of Public Work - Albany	518-457-2744	518-485-0240
Bureau of Public Work - Binghamton	607-721-8005	607-721-8004
Bureau of Public Work - Buffalo	716-847-7159	716-847-7650
Bureau of Public Work - Garden City	516-228-3915	516-794-3518
Bureau of Public Work - Newburgh	845-568-5287	845-568-5332
Bureau of Public Work - New York City	212-932-2419	212-775-3579
Bureau of Public Work - Patchogue	631-687-4882	631-687-4902
Bureau of Public Work - Rochester	585-258-4505	585-258-4708
Bureau of Public Work - Syracuse	315-428-4056	315-428-4671
Bureau of Public Work - Utica	315-793-2314	315-793-2514
Bureau of Public Work - White Plains	914-997-9507	914-997-9523
Bureau of Public Work - Central Office	518-457-5589	518-485-1870

Cattaraugus County General Construction

Boilermaker **11/01/2019**

JOB DESCRIPTION Boilermaker **DISTRICT 12**

ENTIRE COUNTIES

Allegany, Cattaraugus, Chautauqua, Chemung, Erie, Genesee, Livingston, Monroe, Niagara, Ontario, Orleans, Schuyler, Steuben, Wayne, Wyoming, Yates

WAGES

Per hours:	07/01/2019	01/01/2020
		Additional
Boilermaker	\$ 34.10	\$ 1.25

The wage rate will be 90% of the above for Maintenance work on boilers less than 100,000 pph.

Four (4), ten (10) hour days may be worked at straight time during a week, Monday thru Thursday. Friday may be used as a make-up day.

NOTE - In order to use the '4 Day/10 Hour Work schedule', as your normal schedule, you must submit an 'Employer Registration for Use of 4 Day/10 Hour Work Schedule,' form PW30.1; and there must be a dispensation of hours in place on the project. If the PW30.1 is not submitted you may be liable for overtime payments for work over 8 hours per day.

SUPPLEMENTAL BENEFITS

Per hour: \$ 30.15*

*NOTE: \$28.91 of this amount is for every Hour "Paid"

OVERTIME PAY

See (B, E, Q) on OVERTIME PAGE

HOLIDAY

Paid: See (1) on HOLIDAY PAGE
 Overtime: See (5, 6) on HOLIDAY PAGE

REGISTERED APPRENTICES

1st Term at 12 Months
 Terms 3-8 at 6 Months

Per Hour:

1st 65%					
3rd 70%	4th 75%	5th 80%	6th 85%	7th 90%	8th 95%

Supplemental Benefits per hour:

1st to 6th	\$ 29.15**
7th to 8th	\$30.15***

**NOTE: \$27.91 of this amount is for every Hour "Paid"

***NOTE: \$28.91 of this amount is for every Hour "Paid"

12-7

Carpenter - Building **11/01/2019**

JOB DESCRIPTION Carpenter - Building **DISTRICT 12**

ENTIRE COUNTIES

Chautauqua

PARTIAL COUNTIES

Allegany: Entire county except the Township of Alfred.
 Cattaraugus: Entire county except the Township of Perrysburg and the Village of Gowanda.

WAGES

Per hour:	07/01/2019
Carpenter	\$ 27.10
Floorlayer	27.10
Certified Welder	28.10
Hazardous Waste Worker	28.60
Diver-Dry Day	28.10
Dive Tender	28.10
Diver-Wet Day**	61.25

Hazardous Waste Worker: Hazardous sites requiring personal protective equipment.

** Diver rate applies to all hours worked on the day of dive.

Depth pay for divers:	0' to 80'	no additional fee
	81' to 100'	additional \$0.50 per foot
	101' to 150'	additional \$0.75 per foot
	151' and deeper	additional \$1.25 per foot
Penetration pay:	0' to 50'	no additional fee
	51' to 100'	additional \$0.75 per foot
	101' and deeper	additional \$1.00 per foot

Four (4), ten (10) hour days may be worked at straight time during a week, Monday thru Thursday. Friday may be used as a make-up day.

NOTE - In order to use the '4 Day/10 Hour Work Schedule,' as your normal schedule, you must submit an 'Employer Registration for Use of 4 Day/10 Hour Work Schedule,' form PW30.1; and there must be a dispensation of hours in place on the project. If the PW30.1 is not submitted you may be liable for overtime payments for work over 8 hours per day.

SUPPLEMENTAL BENEFITS

Per hour worked:

Carpenter(s)	\$ 19.45
Diver Wet	19.45
Diver Dry & Tender	19.45

OVERTIME PAY

See (B, E, E2, Q) on OVERTIME PAGE

HOLIDAY

Paid: See (1) on HOLIDAY PAGE
 Overtime: See (5, 6) on HOLIDAY PAGE

REGISTERED APPRENTICES

Wages per hour:

One year terms at the following percentage of Journeyman's base wage:

Indentured Prior to 1/1/2016

1st	2nd	3rd	4th
50%	60%	70%	80%

Indentured After 01/01/2016

1st	2nd	3rd	4th	5th
50%	60%	65%	70%	80%

Supplemental benefits per hour worked:

1st	2nd	3rd	4th	5th
\$11.69	\$11.69	\$14.29	\$14.29	\$14.29

12-276B-All

Carpenter - Building

11/01/2019

JOB DESCRIPTION Carpenter - Building

DISTRICT 12

ENTIRE COUNTIES

Erie

PARTIAL COUNTIES

Cattaraugus: Townships of Persia and Perrysburg

WAGES

Per hour: 07/01/2019

Building:

Carpenter	\$ 32.40
FloorLayer	32.40
Certified Welder	33.40
Hazardous Waste Worker	33.90
Diver-Dry Day	33.40
Diver Tender	33.40
Diver-Wet Day***	61.25

Hazardous Waste Worker: Hazardous sites requiring personal protective equipment.

*** Diver rate applies to all hours worked on the day of dive.

Depth pay for divers:	0' to 80'	no additional fee
	81' to 100'	additional \$0.50 per foot
	101' to 150'	additional \$0.75 per foot
	151' and deeper	additional \$1.25 per foot
Penetration pay:	0' to 50'	no additional fee
	51' to 100'	additional \$0.75 per foot
	101' and deeper	additional \$1.00 per foot

Four (4), ten (10) hour days may be worked at straight time during a week, Monday thru Thursday. Friday may be used as a make-up day.

NOTE - In order to use the '4 Day/10 Hour Work schedule' as your normal schedule, you must submit an 'Employer Registration for Use of 4 Day/10 Hour Work Schedule,' form PW30.1; and there must be a dispensation of hours in place on the project. If the PW30.1 is not submitted you may be liable for overtime payments for work over 8 hours per day.

SUPPLEMENTAL BENEFITS

Per hour worked:

Carpenter(s)	\$ 28.18
Diver(s)	28.18

OVERTIME PAY

See (B, E, E2, Q) on OVERTIME PAGE

HOLIDAY

Paid: See (1) on HOLIDAY PAGE
 Overtime: See (5, 6) on HOLIDAY PAGE

REGISTERED APPRENTICES

Wages per hour:

One year terms at the following percentage of Journeyman's base wage:

Indentured Prior to 01/01/2016

1st	2nd	3rd	4th
50%	60%	70%	80%

Indentured After 01/01/2016

1st	2nd	3rd	4th	5th
50%	60%	65%	70%	80%

Supplemental Benefits per hour worked:

1st	2nd	3rd	4th	5th
\$11.75	\$11.75	\$14.35	\$14.35	\$14.35

12-276B-Cat

Carpenter - Building / Heavy&Highway

11/01/2019

JOB DESCRIPTION Carpenter - Building / Heavy&Highway

DISTRICT 2

ENTIRE COUNTIES

Albany, Allegany, Broome, Cattaraugus, Cayuga, Chautauqua, Chemung, Chenango, Clinton, Columbia, Cortland, Delaware, Erie, Essex, Franklin, Fulton, Genesee, Greene, Hamilton, Herkimer, Jefferson, Lewis, Livingston, Madison, Monroe, Montgomery, Niagara, Oneida, Onondaga, Ontario, Orleans, Oswego, Otsego, Rensselaer, Saratoga, Schenectady, Schoharie, Schuyler, Seneca, St. Lawrence, Steuben, Sullivan, Tioga, Tompkins, Ulster, Warren, Washington, Wayne, Wyoming, Yates

PARTIAL COUNTIES

Orange: The area lying on Northern side of Orange County demarcated by a line drawn from the Bear Mountain Bridge continuing east to the Bear Mountain Circle, continue North on 9W to the town of Cornwall where County Road 107 (also known as Quaker Rd) crosses under 9W, then east on County Road 107 to Route 32, then north on Route 32 to Orrs Mills Rd, then west on Orrs Mills Rd to Route 94, continue west and south on Route 94 to the Town of Chester, to the intersection of Kings Highway, continue south on Kings Highway to Bellvale Rd, west on Bellvale Rd to Bellvale Lakes Rd, then south on Bellvale Lakes Rd to Kain Rd, southeast on Kain Rd to Route 17A, then north and southeast along Route 17A to Route 210, then follow Route 210 to NJ Border.

WAGES

Wages per hour:	07/01/2019	07/01/2020	07/01/2021
		Additional	Additional

Carpenter - ONLY for
 Artificial Turf/Synthetic

Sport Surface	\$ 30.88	\$ 1.15	\$ 1.15
---------------	----------	---------	---------

Note - Does not include the operation of equipment. Please see Operating Engineers rates.

SUPPLEMENTAL BENEFITS

Per hour:

Journeyman	\$ 23.10
------------	----------

OVERTIME PAY

See (B, E, Q, X) on OVERTIME PAGE

HOLIDAY

Paid: See (5) on HOLIDAY PAGE

Overtime: See (5, 6, 16) on HOLIDAY PAGE

Notes:

When a holiday falls upon a Saturday, it shall be observed on the preceding Friday. When a holiday falls upon a Sunday, it shall be observed on the following Monday.

An employee taking an unexcused day off the regularly scheduled day before or after a paid Holiday shall not receive Holiday pay.

REGISTERED APPRENTICES

Wages per hour:

One year terms at the following percentage of Journeyman's wage:

1st	2nd	3rd	4th
55%	60%	70%	80%

Supplemental Benefits per hour:

1st year term	\$ 11.55
2nd year term	11.55
3rd year term	14.15
4th year term	14.15

2-42AtSS

Carpenter - Heavy&Highway

11/01/2019

JOB DESCRIPTION Carpenter - Heavy&Highway

DISTRICT 12

ENTIRE COUNTIES

Allegany, Cattaraugus, Chautauqua

WAGES

Per hour: 07/01/2019

Carpenter	\$ 31.23
Certified Welder	32.73
Diver-Dry Day	32.23
Diver-Wet Day**	56.23
Dive Tender	32.23
Hazardous Waste Worker	33.23
Pile Driver	35.11
Millwright	33.38
Effluent & Slurry Diver-Dry Day	48.35
Effluent & Slurry Diver-Wet Day	84.35

Hazardous Waste Worker: Hazardous sites requiring personal protective equipment.

** Diver rate applies to all hours worked on the day of the dive.

Depth pay for divers:	0' to 50'	no additional fee
	51' to 100'	additional \$0.50 per foot
	101' to 150'	additional \$0.75 per foot
	151' to 200'	additional \$1.25 per foot
Penetration pay:	0' to 50'	no additional fee
	51' to 100'	additional \$0.75 per foot
	101' to deeper	additional \$1.00 per foot

Four (4), ten (10) hour days may be worked at straight time during a week, Monday thru Thursday. Friday may be used as a make-up day.

NOTE - In order to use the '4 Day/10 Hour Work schedule', as your normal schedule, you must submit an 'Employer Registration for Use of 4 Day/10 Hour Work Schedule,' form PW30.1; and there must be a dispensation of hours in place on the project. If the PW30.1 is not submitted you may be liable for overtime payments for work over 8 hours per day.

SUPPLEMENTAL BENEFITS

Per hour worked:

Carpenter(s)	\$ 23.10
Diver Wet	24.44
Diver Dry & Tender	24.44
Pile Driver	25.05

OVERTIME PAY

See (B, E, Q) on OVERTIME PAGE

HOLIDAY

Paid: See (2, 17) on HOLIDAY PAGE
 Overtime: See (5, 6) on HOLIDAY PAGE

REGISTERED APPRENTICES

Wages per hour:

One year terms at the following percentage of Journeyman's wage:

Indentured Prior to 01/01/2016

1st	2nd	3rd	4th
55%	60%	70%	80%

Indentured After 01/01/2016

1st	2nd	3rd	4th	5th
55%	60%	65%	70%	80%

Supplemental benefits per hour worked:

1st	2nd	3rd	4th	5th
\$11.55	\$11.55	\$14.15	\$14.15	\$14.15

12-276HH-All

Electrician

11/01/2019

JOB DESCRIPTION Electrician

DISTRICT 3

ENTIRE COUNTIES

Erie

PARTIAL COUNTIES

Cattaraugus: Only the Townships of Ashford, East Otto, Ellicottville, Farmersville, Freedom, Franklinville, Lyndon, Machias, Mansfield, New Albion, Otto, Perrysburg, Persia and Yorkshire.

Genesee: Only the Townships of Alabama, Alexander, Darien, Oakfield, Pembroke and that portion of the Towns of Batavia and Elba that are west of Little Tonawanda Creek; Tonawanda Creek; the City limits of Batavia (in effect prior to Feb. 1, 1970) and State Highway 98 north of the City of Batavia, then north on Highway 98 to the Orleans County line.

Wyoming: Only the Townships of Arcade, Attica, Bennington, Eagle, Java, Orangeville, Sheldon and Wethersfield.

WAGES

Per hour:	07/01/2019	06/01/2020
		Additional
Electrician*	\$ 35.64	\$1.80

* Includes teledata work

When shift work is mandated either in the job specification or by the contracting agency the following premiums apply:

17.3% for work from 4:30PM - 1:00AM

31.4% for work from 12:30AM - 9:00AM

Additional \$0.50/hr in shafts over 25 ft. deep and in underground tunnels over 75 ft. long.

Additional \$0.75/hr for work on toothpicks, structural steel, temporary platforms, swinging scaffolds, boatswain chairs, smoke stacks or water towers 30 ft above the floor or for work on rolling scaffolds and ladders over 50 ft.

Additional \$1.50/hr for Cable Splicers on such work as lead, and shielded cable and splices or terminations on cable 5KV and above.

Additional \$1.00/hr for Hot work (Atomic plants).

Additional \$2.00/hr for work on radio, TV, light towers and floating platforms or climbing ladders in excess of 100 ft. high.

SUPPLEMENTAL BENEFITS

Per hour:

\$ 28.10*

* NOTE - add 3% of the posted straight time or applicable premium wage rate.

OVERTIME PAY

See (B, E, Q) on OVERTIME PAGE

HOLIDAY

Paid: See (1) on HOLIDAY PAGE
 Overtime: See (5, 6) on HOLIDAY PAGE

REGISTERED APPRENTICES

Wages per hour:

Hour terms at the following wages:

0 to 1000 to 2000 to 3500 to 5000 to 6500 to 8000
 \$ 13.20 \$ 14.25 \$ 16.05 \$ 19.60 \$ 24.95 \$ 28.50

Supplemental benefits per hour:

0 to 1000 to 5000 to 8000
 \$ 12.51* \$ 22.75* \$ 28.10*

* NOTE - add 3% of the posted straight time or applicable premium wage rate.

3-41

Electrician

11/01/2019

JOB DESCRIPTION Electrician

DISTRICT 3

ENTIRE COUNTIES

Chautauqua

PARTIAL COUNTIES

Allegany: Only the Townships of Alma, Bolivar, Centerville, Clarksville, Cuba, Friendship, Genesee, New Hudson, Rushford, Wirt and that portion of the Townships of Amity, Angelica, Belfast, Caneadea and Scio that are west of the Genesee River.
 Cattaraugus: Only the Townships of Allegany, Carrollton, Cold Spring, Conewango, Dayton, Great Valley, Hinsdale, Humphrey, Ischua, Leon, Little Valley, Napoli, Olean, Portville, Red House, Randolph, Salamanca and South Valley.

WAGES

Per hour:	07/01/2019	01/01/2020 Additional	01/01/2021 Additional
Electrician*	\$ 36.51	\$ 1.70	\$ 1.90

* Includes teledata work.

When shift work is mandated either in the job specification or by the contracting agency the following premiums apply:

17.3% for work from 4:30PM - 1:00AM

31.4% for work from 12:30AM - 9:00AM

Additional 15% above wage for work 40' above floor, or in underground mines or tunnels or from suspension-type personnel lift equipment.

SUPPLEMENTAL BENEFITS

Per hour:

\$ 22.41*

NOTE - add 3% of the posted straight time or applicable premium wage rate.

* NOTE - \$10.72 of this amount is paid at straight time, the remaining balance of \$11.69 is paid at the same premium as the wages.

OVERTIME PAY

See (B, *E, Q) on OVERTIME PAGE

* Double-time for all work on Saturday in excess of 10 hours.

HOLIDAY

Paid: See (1) on HOLIDAY PAGE

Overtime: See (5, 6) on HOLIDAY PAGE

REGISTERED APPRENTICES

Wages per hour:

Hour terms at the following percentage of Journeyman's wage:

0 to	1001 to	2001 to	2751 to	3501 to	4251 to	5001 to	5751 to	6601 to	7351 to
1000	2000	2750	3500	4250	5000	5750	6600	7350	8200
40%	45%	55%	60%	65%	70%	75%	80%	85%	90%

Supplemental benefits per hour:

07/01/2018

\$ 8.27 \$ 8.27 \$ 14.89* \$ 15.27* \$ 18.32* \$ 18.90* \$ 19.49* \$ 20.07* \$ 20.66* \$ 21.24*

NOTE - add 3% of the posted straight time or applicable premium wage rate to all terms.

* Note - \$10.72 of this amount is paid at straight time, the remaining balance is paid at the same premium as the wages.

3-106

Elevator Constructor

11/01/2019

JOB DESCRIPTION Elevator Constructor

DISTRICT 3

ENTIRE COUNTIES

Allegany, Cattaraugus, Chautauqua, Erie, Genesee, Niagara, Orleans, Wyoming

WAGES

Per hour:	07/01/2019
Elevator Constructor	\$ 49.81
Helper	34.87

**** IMPORTANT NOTICE - EFFECTIVE 04/01/2009 ****

Four (4), ten (10) hour days may be worked at straight time during a week, Monday thru Thursday or Tuesday thru Friday.

NOTE - In order to use the '4 Day/10 Hour Work schedule', as your normal schedule, you must submit an 'Employer Registration for Use of 4 Day/10 Hour Work Schedule,' form PW30.1; and there must be a dispensation of hours in place on the project. If the PW30.1 is not submitted you may be liable for overtime payments for work over 8 hours per day.

SUPPLEMENTAL BENEFITS

Per hour:	\$ 33.71
-----------	----------

Note - add 6% of regular hourly rate for all hours worked.

OVERTIME PAY

See (D, O) on OVERTIME PAGE

HOLIDAY

Paid:	See (5, 6, 15, 16) on HOLIDAY PAGE
Overtime:	See (5, 6, 15, 16) on HOLIDAY PAGE

REGISTERED APPRENTICES

Wages per hour:

One year (1,700 hour each) terms at the following percentage of Journeyman's wage:

1st*	2nd	3rd	4th
55%	65%	70%	80%

Supplemental benefits per hour:	\$ 33.71
---------------------------------	----------

* Note - 0-6 months of the 1st year term is paid at 50% of Journeyman's wage with no Supplemental benefits.

Note - add 6% of regular hourly rate for all hours worked.

3-14

Glazier

11/01/2019

JOB DESCRIPTION Glazier

DISTRICT 3

ENTIRE COUNTIES

Allegany, Cattaraugus, Chautauqua, Erie, Genesee, Niagara, Orleans, Wyoming

WAGES

Per hour:	07/01/2019	05/01/2020	05/01/2021
		Additional	Additional
Glazier	\$ 27.12	\$ 1.20	\$ 1.20
Working off Suspended			
Scaffold (Swing Stage)	28.12	1.20	1.20
Maintenance	16.94*	0.85	0.90

* Note - This rate to be used only for all repair and replacement work such as glass breakage, glass replacement, door repair and board ups.

**** IMPORTANT NOTICE ****

Four (4), ten (10) hour days may be worked at straight time during a week, Monday thru Thursday. Friday may be used as a make-up day.

NOTE - In order to use the '4 Day/10 Hour Work schedule', as your normal schedule, you must submit an 'Employer Registration for Use of 4 Day/10 Hour Work Schedule,' form PW30.1; and there must be a dispensation of hours in place on the project. If the PW30.1 is not submitted you may be liable for overtime payments for work over 8 hours per day.

SUPPLEMENTAL BENEFITS

Per hour:	
Journeyman Glazier	\$ 22.50
Maintenance	14.20

OVERTIME PAY

See (B, E2, F, R) on OVERTIME PAGE

HOLIDAY

Paid: See (1) on HOLIDAY PAGE for Glazier and Glazier Apprentices.
Paid: See (5, 6) on HOLIDAY PAGE for Maintenance
Overtime: See (5, 6) on HOLIDAY PAGE.

REGISTERED APPRENTICES

Wages per hour:

Glazier: 1000 hour terms at the following percentage of Journeyman's wage:

1st	2nd	3rd	4th	5th	6th	7th	8th
50%	55%	60%	65%	70%	75%	80%	90%

Supplemental benefits per hour:

1st & 2nd terms	\$ 7.95
3rd & 4th terms	8.80
All other terms	10.20

3-660

Insulator - Heat & Frost

11/01/2019

JOB DESCRIPTION Insulator - Heat & Frost

DISTRICT 3

ENTIRE COUNTIES

Allegany, Cattaraugus, Chautauqua, Erie, Niagara, Wyoming

PARTIAL COUNTIES

Genesee: Only the Townships of Alabama, Alexander, Darien, Oakfield and Pembroke.

WAGES

Per Hour: 07/01/2019
Heat & Frost Insulator \$ 33.70

SUPPLEMENTAL BENEFITS

Per hour: \$ 23.89

OVERTIME PAY

See (B, *E, **Q) on OVERTIME PAGE

* Note - Double time after 10 hours on Saturday.

** Note - Triple time on Labor Day if WORKED.

HOLIDAY

Paid: See (1) on HOLIDAY PAGE
Overtime: See (5, 6) on HOLIDAY PAGE

REGISTERED APPRENTICES

Wages per hour:

One year terms at the following percentage of Journeyman's wage:

1st	2nd	3rd	4th
50%	60%	70%	80%

Supplemental Benefits per hour:

1st and 2nd	\$ 18.99
All other terms	\$ 23.89

3-4

Ironworker

11/01/2019

JOB DESCRIPTION Ironworker

DISTRICT 3

ENTIRE COUNTIES

Cattaraugus, Chautauqua

PARTIAL COUNTIES

Allegany: Entire county except the Towns of Birdsell, Burns and Grove.

Erie: All except the Town of Grand Island north of Whitehaven Road.

Genesee: Only the Townships of Alabama, Alexander, Darien and Pembroke

Steuben: Only the Townships of Canisteo, Freemont, Greenwood, Hartsville, Hornell, Hornellsville, Howard, Jasper, Troupsburg and West Union

Wyoming: Only the Townships of Arcade, Attica, Bennington, Eagle, Gainsville, Java, Orangeville, Pike, Sheldon, Warsaw and Wethersfield.

WAGES

Per hour:	07/01/2019	07/01/2020 Additional	07/01/2021 Additional
Structural	\$ 31.10	\$ 1.25	\$ 1.25
Ornamental	31.10	1.25	1.25
Layout	31.10	1.25	1.25
Rodmen	31.10	1.25	1.25
Reinforcing	31.10	1.25	1.25
Welders	31.10	1.25	1.25
Riggers & Mach. Movers	31.10	1.25	1.25
Curtain Wall Erector	31.10	1.25	1.25
Window Erector	28.75	1.25	1.25
Fence Erector	29.67	1.25	1.25

SUPPLEMENTAL BENEFITS

Per hour:

Fence erectors	\$ 27.15
All others	28.65

OVERTIME PAY

See (B, E, Q) on OVERTIME PAGE

HOLIDAY

Paid: See (1) on HOLIDAY PAGE
 Overtime: See (5, 6) on HOLIDAY PAGE

REGISTERED APPRENTICES

Wages per hour:

One year terms at the following wage:

1st	2nd	3rd	4th
\$ 16.50	\$ 18.50	\$ 20.50	\$ 22.50

Supplemental benefits per hour:

1st	2nd	3rd	4th
\$ 12.08	\$ 21.66	\$ 23.02	\$ 24.39

3-6

Laborer - Building

11/01/2019

JOB DESCRIPTION Laborer - Building

DISTRICT 3

ENTIRE COUNTIES

Allegany, Chautauqua

PARTIAL COUNTIES

Cattaraugus: Entire county except the Town of Perrysburg and the Village of Gowanda.

WAGES

Per hour:	07/01/2019	07/01/2020 Additional	07/01/2021 Additional
Basic and Flagman	\$ 24.27	\$ 1.00	\$ 1.10
Blaster, Nozzelman, Curb	25.27	1.00	1.10
and Flatwork Formsetter not	25.27	1.00	1.10
on structures, Pipelayer	25.27	1.00	1.10
Work 40 ft. and up	24.42	1.00	1.10
Hazardous Waste	25.77	1.00	1.10
Deleader & Asbestos Removal	26.27	1.00	1.10
OSHA Level C or	26.27	1.00	1.10
greater protective suit or	26.27	1.00	1.10
any anti-contamination	26.27	1.00	1.10
clothing is required	26.27	1.00	1.10
With supplied air respirator	27.27	1.00	1.10

**** IMPORTANT NOTICE ****

Four (4), ten (10) hour days may be worked at straight time during a week, Monday thru Thursday. Friday may be used as a make-up day. Saturday may be used as a make-up day at time and one half of the hourly rate.

NOTE - In order to use the '4 Day/10 Hour Work schedule', as your normal schedule, you must submit an 'Employer Registration for Use of 4 Day/10 Hour Work Schedule,' form PW30.1; and there must be a dispensation of hours in place on the project. If the PW30.1 is not submitted you may be liable for overtime payments for work over 8 hours per day.

SUPPLEMENTAL BENEFITS

Per hour: \$ 17.27

OVERTIME PAY

See (B, E, E2, Q) on OVERTIME PAGE

HOLIDAY

Paid: See (1) on HOLIDAY PAGE
Overtime: See (5, 6) on HOLIDAY PAGE

REGISTERED APPRENTICES

Wages per hour:
1000 hour terms at the following percentage of Journeyman's wage:

1st	2nd	3rd	4th
70%	80%	85%	90%

Supplemental benefits per hour: \$ 17.27

3-621b

Laborer - Building **11/01/2019**

JOB DESCRIPTION Laborer - Building

DISTRICT 3

ENTIRE COUNTIES

Erie

PARTIAL COUNTIES

Cattaraugus: Only the Townships of Perrysburg and the Village Gowanda.

WAGES

CLASS A: Basic, Safety Man, Flagman, Tool Room Man, Nurseryman, Demolition Worker, Top Man, Wrecker, IBC Barriers Except on Structures, Guard Rail, Asphalt Shovelers, Foundation Laborer over 8' in Depth, Hod Carriers, Plaster Tender, Plaster Scaffold Builder, Pneumatic Gas, Electric Tool Operator including all forms of Busters, Jackhammers and Chipping Guns, Steel Burners.

CLASS B: Mortar Mixer, Asphalt Smoothers, Pneumatic Gas, Electric Tool Operator including all forms of Busters, Jackhammers and Chipping Guns over 8' in depth.

CLASS C: Worker on any Swing Scaffold, Blaster, Plumbing Laborer, Wagon Drill Operator, Bottomman (caisson or cofferdam), Laser Setter, Asphalt Rakers, Asphalt Screed Man.

CLASS D: Stone Cutter, Curb Setter and Flag Layer.

CLASS E: Wearing of replaceable cartridge respirator.

CLASS F: Asbestos Removal, Deleader.

CLASS G: Hazardous Waste Worker.

Per hour:	07/01/2019	07/01/2020
Building Laborer:		Additional
CLASS A	\$ 27.88	\$ 1.75
CLASS B	28.05	1.75
CLASS C	28.16	1.75
CLASS D	28.63	1.75
CLASS E	28.88	1.75
CLASS F	29.38	1.75
CLASS G	29.88	1.75

SUPPLEMENTAL BENEFITS

Per hour: \$ 25.90

OVERTIME PAY

See (B, E, E2, Q) on OVERTIME PAGE

HOLIDAY

Paid: See (22) on HOLIDAY PAGE
Overtime: See (5, 6) on HOLIDAY PAGE

REGISTERED APPRENTICES

Wages per hour:

Hour terms at the following percentage of Journeyman's wage:

0 to 500 to 1000 to 1500 to 2000 to 2500 to 3000 to 4000
55% 60% 65% 70% 75% 80% 90%

Supplemental benefits per hour:

\$ 25.90

3-210b

Laborer - Heavy&Highway

11/01/2019

JOB DESCRIPTION Laborer - Heavy&Highway

DISTRICT 3

ENTIRE COUNTIES

Allegany, Cattaraugus

PARTIAL COUNTIES

Chautauqua: Only the Townships of Busti, Carroll, Chautauqua, Clymer, Ellery, Ellicott, Ellington, French Creek, Gerry, Harmony, Kiantone, Mina, North Harmony, Poland, Sherman, Stockton and the City of Jamestown.

WAGES

GROUP A: Basic, Drill Helper, Flagman, Outboard and Hand Boats. Chain Saw, Concrete Aggregate Bin, Concrete Bootmen, Gin Buggy, Hand or Machine Vibrator, Jack Hammer, Mason Tender, Mortar Mixer, Pavement Breaker, Handlers of Steel Mesh, Small Generators for Laborers' Tools, Pipe Layers, Vibrator Type Rollers, Tamper, Drill Doctor, Water Pump Operator (2" and Single Diaphragm), Nozzle (Asphalt, Guniting, Seeding, and Sand Blasting), Laborers on Chain Link Fence Erection, Rock Splitter and Power Unit, Pusher Type Concrete Saw and all other Gas, Electric, Oil and Air Tool Operators, Wrecking Laborer, Grade Checker.

GROUP B: All Rock or Drilling Machine Operators (Except Quarry Master and Similar Type), Acetylene Torch Operators and Powderman. Blasters, Curb and Flatwork Formsetters not on structures, Stone or Granite Curb Setters, Designated Asphalt Rakers (not on cold patch), Tail or Screw Operator on Asphalt Paver.

Per hour:	07/01/2019	07/01/2020	07/01/2021
		Additional	Additional
GROUP A	\$ 27.84	\$1.50	\$1.50
GROUP B	28.24	\$1.50	\$1.50

Hazardous waste removal, lead abatement, asbestos abatement add \$ 1.50

SUPPLEMENTAL BENEFITS

Per hour:

\$ 22.15

OVERTIME PAY

See (B, E, Q) on OVERTIME PAGE

HOLIDAY

Paid: See (5, 6) on HOLIDAY PAGE

Overtime: See (5, 6) on HOLIDAY PAGE

REGISTERED APPRENTICES

Wages per:

1000 hour terms at the following percentage of Journeyman's wage:

1st 2nd 3rd 4th
70% 80% 85% 90%

Supplemental benefits per hour:

\$ 22.15

3-621h Zone 1

Lineman Electrician

11/01/2019

JOB DESCRIPTION Lineman Electrician

DISTRICT 6

ENTIRE COUNTIES

Albany, Allegany, Broome, Cattaraugus, Cayuga, Chautauqua, Chemung, Chenango, Clinton, Columbia, Cortland, Delaware, Dutchess, Erie, Essex, Franklin, Fulton, Genesee, Greene, Hamilton, Herkimer, Jefferson, Lewis, Livingston, Madison, Monroe, Montgomery, Niagara, Oneida, Onondaga, Ontario, Orange, Orleans, Oswego, Otsego, Putnam, Rensselaer, Rockland, Saratoga, Schenectady, Schoharie, Schuyler, Seneca, St. Lawrence, Steuben, Sullivan, Tioga, Tompkins, Ulster, Warren, Washington, Wayne, Wyoming, Yates

WAGES

Per hour:

NOTE: Includes Teledata Work within ten (10) feet of High Voltage Transmission Lines

Below rates applicable on all overhead and underground distribution and maintenance work, and all overhead and underground transmission line work and the installation of fiber optic cable where no other construction trades are or have been involved. (Ref #14.01.01)

	07/01/2019	05/04/2020
Lineman, Technician	\$ 52.05	\$ 53.50
Crane, Crawler Backhoe	52.05	53.50
Welder, Cable Splicer	52.05	53.50
Digging Mach. Operator	46.85	48.15
Tractor Trailer Driver	44.24	45.48
Groundman, Truck Driver	41.64	42.80
Equipment Mechanic	41.64	42.80
Flagman	31.23	32.10

Additional \$1.00 per hour for entire crew when a helicopter is used.

Below rates applicable on all electrical sub-stations, switching structures, fiber optic cable and all other work not defined as "Utility outside electrical work". (Ref #14.02.01-A)

	07/01/2019	05/04/2020
Lineman, Technician	\$ 52.05	\$ 53.50
Crane, Crawler Backhoe	52.05	53.50
Cable Splicer	57.26	58.85
Certified Welder - Pipe Type Cable	54.65	56.18
Digging Mach. Operator	46.85	48.15
Tractor Trailer Driver	44.24	45.48
Groundman, Truck Driver	41.64	42.80
Equipment Mechanic	41.64	42.80
Flagman	31.23	32.10

Additional \$1.00 per hour for entire crew when a helicopter is used.

Below rates apply on switching structures, maintenance projects, railroad catenary install/maintenance third rail installation, bonding of rails and pipe type cable and installation of fiber optic cable. (Ref #14.02.01-B)

	07/01/2019	05/04/2020
Lineman, Tech, Welder	\$ 53.37	\$ 54.82
Crane, Crawler Backhoe	53.37	54.82
Cable Splicer	58.71	60.30
Certified Welder - Pipe Type Cable	56.04	57.56
Digging Mach. Operator	48.03	49.34
Tractor Trailer Driver	45.36	46.60
Groundman, Truck Driver	42.70	43.86
Equipment Mechanic	42.70	43.86
Flagman	32.02	32.89

Additional \$1.00 per hour for entire crew when a helicopter is used.

Below rates applicable on all overhead and underground transmission line work & fiber optic cable where other construction trades are or have been involved. This applies to transmission line work only, not other construction. (Ref #14.03.01)

	07/01/2019	05/04/2020
Lineman, Tech, Welder	\$ 54.56	\$ 56.01
Crane, Crawler Backhoe	54.56	56.01
Cable Splicer	54.56	56.01
Digging Mach. Operator	49.10	50.41
Tractor Trailer Driver	46.38	47.61
Groundman, Truck Driver	43.65	44.81
Equipment Mechanic	43.65	44.81
Flagman	32.74	33.61

Additional \$1.00 per hour for entire crew when a helicopter is used.

NOTE: THE FOLLOWING RATES WILL APPLY ON ALL CONTRACTING AGENCY MANDATED MULTIPLE SHIFTS OF AT LEAST FIVE (5) DAYS DURATION WORKED BETWEEN THE HOURS LISTED BELOW:

1ST SHIFT	8:00 AM to 4:30 PM REGULAR RATE
2ND SHIFT	4:30 PM to 1:00 AM REGULAR RATE PLUS 17.3 %
3RD SHIFT	12:30 AM to 9:00 AM REGULAR RATE PLUS 31.4 %

**** IMPORTANT NOTICE ****

Four (4), ten (10) hour days may be worked at straight time during a week, Monday thru Thursday. Friday may be used as a make-up day.
 *Effective 05/06/2013, Tuesday thru Friday may be worked with no make-up day.

NOTE - In order to use the '4 Day/10 Hour Work schedule', as your normal schedule, you must submit an 'Employer Registration for Use of 4 Day/10 Hour Work Schedule,' form PW30.1; and there must be a dispensation of hours in place on the project. If the PW30.1 is not submitted you may be liable for overtime payments for work over 8 hours per day.

SUPPLEMENTAL BENEFITS

Per hour worked (also required on non-worked holidays):

The following SUPPLEMENTAL BENEFITS apply to all classification categories of CONSTRUCTION, TRANSMISSION and DISTRIBUTION.

Journeyman	\$ 24.15	\$ 24.90
	*plus 6.75% of hourly wage	*plus 6.75% of hourly wage

*The 6.75% is based on the hourly wage paid, straight time rate or premium rate.

OVERTIME PAY

See (B, E, Q,) on OVERTIME PAGE. *Note* Double time for all emergency work designated by the Dept. of Jurisdiction.
 NOTE: WAGE CAP...Double the straight time hourly base wage shall be the maximum hourly wage compensation for any hour worked.
 Contractor is still responsible to pay the hourly benefit amount for each hour worked.

HOLIDAY

Paid See (5, 6, 8, 13, 25) on HOLIDAY PAGE plus Governor of NYS Election Day.
 Overtime See (5, 6, 8, 13, 25) on HOLIDAY PAGE plus Governor of NYS Election Day.

NOTE: All paid holidays falling on Saturday shall be observed on the preceding Friday. All paid holidays falling on Sunday shall be observed on the following Monday. Supplements for holidays paid at straight time.

REGISTERED APPRENTICES

WAGES: 1000 hour terms at the following percentage of the applicable Journeyman Lineman wage.

1st	2nd	3rd	4th	5th	6th	7th
60%	65%	70%	75%	80%	85%	90%

SUPPLEMENTAL BENEFITS: Same as Journeyman

6-1249a

Lineman Electrician - Teledata

11/01/2019

JOB DESCRIPTION Lineman Electrician - Teledata

DISTRICT 6

ENTIRE COUNTIES

Albany, Allegany, Broome, Cattaraugus, Cayuga, Chautauqua, Chemung, Chenango, Clinton, Columbia, Cortland, Delaware, Dutchess, Erie, Essex, Franklin, Fulton, Genesee, Greene, Hamilton, Herkimer, Jefferson, Lewis, Livingston, Madison, Monroe, Montgomery, Niagara, Oneida, Onondaga, Ontario, Orange, Orleans, Oswego, Otsego, Putnam, Rensselaer, Rockland, Saratoga, Schenectady, Schoharie, Schuyler, Seneca, St. Lawrence, Steuben, Sullivan, Tioga, Tompkins, Ulster, Warren, Washington, Wayne, Westchester, Wyoming, Yates

WAGES

Per hour:

For outside work, stopping at first point of attachment (demarcation).

	07/01/2019	01/01/2020	01/01/2021
Cable Splicer	\$ 32.78	\$ 33.77	\$ 34.78
Installer, Repairman	\$ 31.12	\$ 32.05	\$ 33.01

Teledata Lineman	\$ 31.12	\$ 32.05	\$ 33.01
Tech., Equip. Operator	\$ 31.12	\$ 32.05	\$ 33.01
Groundman	\$ 16.49	\$ 16.99	\$ 17.50

NOTE: EXCLUDES Teledata work within ten (10) feet of High Voltage (600 volts and over) transmission lines. For this work please see LINEMAN.

NOTE: THE FOLLOWING RATES WILL APPLY ON ALL CONTRACTING AGENCY MANDATED MULTIPLE SHIFTS OF AT LEAST FIVE (5) DAYS DURATION WORKED:

1ST SHIFT	REGULAR RATE
2ND SHIFT	REGULAR RATE PLUS 10%
3RD SHIFT	REGULAR RATE PLUS 15%

SUPPLEMENTAL BENEFITS

Per hour:

Journeyman	\$ 4.73	\$ 4.73	\$ 4.73
	*plus 3% of wage paid	*plus 3% of wage paid	*plus 3% of wage paid

*The 3% is based on the hourly wage paid, straight time rate or premium rate.

OVERTIME PAY

See (B, E, Q) on OVERTIME PAGE

NOTE: WAGE CAP...Double the straight time hourly base wage shall be the maximum hourly wage compensation for any hour worked. Contractor is still responsible to pay the hourly benefit amount for each hour worked.

HOLIDAY

Paid: See (1) on HOLIDAY PAGE
 Overtime: See (5, 6, 16) on HOLIDAY PAGE

6-1249LT - Teledata

Lineman Electrician - Traffic Signal, Lighting **11/01/2019**

JOB DESCRIPTION Lineman Electrician - Traffic Signal, Lighting **DISTRICT 6**

ENTIRE COUNTIES

Albany, Allegany, Broome, Cattaraugus, Cayuga, Chautauqua, Chemung, Chenango, Clinton, Cortland, Delaware, Erie, Essex, Franklin, Fulton, Genesee, Greene, Hamilton, Herkimer, Jefferson, Lewis, Livingston, Madison, Monroe, Montgomery, Niagara, Oneida, Onondaga, Ontario, Orleans, Oswego, Otsego, Rensselaer, Saratoga, Schenectady, Schoharie, Schuyler, Seneca, St. Lawrence, Steuben, Sullivan, Tioga, Tompkins, Warren, Washington, Wayne, Wyoming, Yates

WAGES

Lineman/Technician shall perform all overhead aerial work. A Lineman/Technician on the ground will install all electrical panels, connect all grounds, install and connect all electrical conductors which includes, but is not limited to road loop wires; conduit and plastic or other type pipes that carry conductors, flex cables and connectors, and to oversee the encasement or burial of such conduits or pipes.

A Groundman/Groundman Truck Driver shall: Build and set concrete forms, handle steel mesh, set footer cages, transport concrete in a wheelbarrow, hand or machine concrete vibrator, finish concrete footers, mix mortar, grout pole bases, cover and maintain footers while curing in cold weather, operate jack hammer, operate hand pavement breaker, tamper, concrete and other motorized saws, as a drill helper, operate and maintain generators, water pumps, chainsaws, sand blasting, operate mulching and seeding machine, air tools, electric tools, gas tools, load and unload materials, hand shovel and/or broom, prepare and pour mastic and other fillers, assist digger operator equipment operator in ground excavation and restoration, landscape work and painting. Only when assisting a lineman technician, a groundman/groundman truck driver may assist in installing conduit, pipe, cables and equipment.

A flagger's duties shall consist of traffic control only.
 (Ref #14.01.01)

Per hour:

	07/01/2019	05/04/2020
Lineman, Technician	\$ 45.00	\$ 46.20
Crane, Crawler Backhoe	45.00	46.20
Certified Welder	47.25	48.51
Digging Machine	40.50	41.58
Tractor Trailer Driver	38.25	39.27
Groundman, Truck Driver	36.00	36.96
Equipment Mechanic	36.00	36.96
Flagman	27.00	27.72

Above rates applicable on all Lighting and Traffic Signal Systems with the installation, testing, operation, maintenance and repair of all traffic control and illumination projects, traffic monitoring systems, road weather information systems and the installation of Fiber Optic Cable.

NOTE: THE FOLLOWING RATES WILL APPLY ON ALL CONTRACTING AGENCY MANDATED MULTIPLE SHIFTS OF AT LEAST FIVE (5) DAYS DURATION WORKED BETWEEN THE HOURS LISTED BELOW:

1ST SHIFT	8:00 AM TO 4:30 PM	REGULAR RATE
2ND SHIFT	4:30 PM TO 1:00 AM	REGULAR RATE PLUS 17.3%
3RD SHIFT	12:30 AM TO 9:00 AM	REGULAR RATE PLUS 31.4%

**** IMPORTANT NOTICE ****

Four (4), ten (10) hour days may be worked at straight time during a week, Monday thru Thursday. Friday may be used as a make-up day.
*Effective 05/06/2013, Tuesday thru Friday may be worked with no make-up day.

NOTE - In order to use the '4 Day/10 Hour Work schedule', as your normal schedule, you must submit an 'Employer Registration for Use of 4 Day/10 Hour Work Schedule,' form PW30.1; and there must be a dispensation of hours in place on the project. If the PW30.1 is not submitted you may be liable for overtime payments for work over 8 hours per day.

SUPPLEMENTAL BENEFITS

Per hour worked (but also required on non-worked holidays):

Journeyman	\$ 24.15	\$ 24.90
	*plus 6.75% of hourly wage	*plus 6.75% of hourly wage

*The 6.75% is based on the hourly wage paid, straight time rate or premium rate.
Supplements paid at STRAIGHT TIME rate for holidays.

OVERTIME PAY

See (B, E, Q) on OVERTIME PAGE. *Note* Double time for all emergency work designated by the Dept. of Jurisdiction.
NOTE: WAGE CAP...Double the straight time hourly base wage shall be the maximum hourly wage compensation for any hour worked.
Contractor is still responsible to pay the hourly benefit amount for each hour worked.

HOLIDAY

Paid: See (5, 6, 8, 13, 25) on HOLIDAY PAGE plus Governor of NYS Election Day.
Overtime: See (5, 6, 8, 13, 25) on HOLIDAY PAGE plus Governor of NYS Election Day.

NOTE: All paid holidays falling on Saturday shall be observed on the preceding Friday. All paid holidays falling on Sunday shall be observed on the following Monday. Supplements for holidays paid at straight time.

REGISTERED APPRENTICES

WAGES: Per hour. 1000 hour terms.

	07/01/2019	05/04/2020
1st term	\$ 27.00	\$ 27.72
2nd term	29.25	30.03
3rd term	31.50	32.34
4th term	33.75	34.65
5th term	36.00	36.96
6th term	38.25	39.27
7th term	40.50	41.58

SUPPLEMENTAL BENEFITS: Same as Journeyman

6-1249a-LT

Lineman Electrician - Tree Trimmer

11/01/2019

JOB DESCRIPTION Lineman Electrician - Tree Trimmer

DISTRICT 6

ENTIRE COUNTIES

Albany, Allegany, Broome, Cattaraugus, Cayuga, Chautauqua, Chemung, Chenango, Clinton, Columbia, Cortland, Delaware, Dutchess, Erie, Essex, Franklin, Fulton, Genesee, Greene, Hamilton, Herkimer, Jefferson, Lewis, Livingston, Madison, Monroe, Montgomery, Niagara, Oneida, Onondaga, Ontario, Orange, Orleans, Oswego, Otsego, Putnam, Rensselaer, Rockland, Saratoga, Schenectady, Schoharie, Schuyler, Seneca, St. Lawrence, Steuben, Sullivan, Tioga, Tompkins, Ulster, Warren, Washington, Wayne, Wyoming, Yates

WAGES

Per hour:

Applies to line clearance, tree work and right-of-way preparation on all new or existing energized overhead or underground electrical, telephone and CATV lines. This also would include stump removal near underground energized electrical lines, including telephone and CATV lines.

07/01/2019

Tree Trimmer	\$ 25.79
Equipment Operator	22.81
Equipment Mechanic	22.81
Truck Driver	18.99
Groundman	15.64
Flag person	11.27

SUPPLEMENTAL BENEFITS

Per hour worked (but also required on non-worked holidays):

Journeyman	\$ 9.98
	*plus 3% of hourly wage

* The 3% is based on the hourly wage paid, straight time rate or premium rate.

OVERTIME PAY

See (B, E, Q) on OVERTIME PAGE

NOTE: WAGE CAP...Double the straight time hourly base wage shall be the maximum hourly wage compensation for any hour worked. Contractor is still responsible to pay the hourly benefit amount for each hour worked.

HOLIDAY

Paid: See (5, 6, 8, 15, 16, 25) on HOLIDAY PAGE

Overtime: See (5, 6, 8, 15, 16, 25) on HOLIDAY PAGE

NOTE: All paid holidays falling on a Saturday shall be observed on the preceding Friday.

All paid holidays falling on a Sunday shall be observed on the following Monday.

6-1249TT

Mason - Building

11/01/2019

JOB DESCRIPTION Mason - Building

DISTRICT 5

ENTIRE COUNTIES

Chautauqua

PARTIAL COUNTIES

Allegany: Entire county except the Townships of Alfred, Almond, Andover and Burns.

Cattaraugus: Entire county except the Township of Perrysburg and the Village of Gowanda.

WAGES

Per hour:	07/01/2019	07/01/2020	07/01/2021
Building:		Additional	Additional
Bricklayer Cement	\$ 31.83	\$ 1.00	\$ 1.15
Mason, Plasterer, Stone			
Mason, Tuck Pointer			

Four (4), ten (10) hour days may be worked at straight time during a week, Monday thru Thursday. Friday may be used as a make-up day.

NOTE - In order to use the '4 Day/10 Hour Work Schedule,' as your normal schedule, you must submit an 'Employer Registration for Use of 4 Day/10 Hour Work Schedule,' form PW30.1; and there must be a dispensation of hours in place on the project. If the PW30.1 is not submitted you may be liable for overtime payments for work over 8 hours per day.

SUPPLEMENTAL BENEFITS

Per hour:

Journeyman	\$ 20.87
------------	----------

OVERTIME PAY

See (B,E,E2*,Q) on OVERTIME PAGE

*Note - Or other conditions beyond the employer's control such as fire or natural disaster.

HOLIDAY

Paid: See (1) on HOLIDAY PAGE

Overtime: See (5, 6) on HOLIDAY PAGE

REGISTERED APPRENTICES

Wages per hour:

One year terms at the following percentage of Journeyman's wage:

1st	2nd	3rd	4th
\$ 19.08	\$ 21.90	\$ 25.21	\$ 28.53

Supplemental benefits per hour:

1st	2nd	3rd	4th
\$ 12.46	\$ 14.93	\$ 16.91	\$ 18.88

5-3B - Jam - Z2

Mason - Building

11/01/2019

JOB DESCRIPTION Mason - Building

DISTRICT 3

ENTIRE COUNTIES

Erie, Niagara

PARTIAL COUNTIES

Cattaraugus: Only the Township of Perrysburg and the Village of Gowanda.

WAGES

Per hour:	07/01/2019
Plasterer	\$ 30.15

Additional \$3.00/hr for work on swing stage over 20 feet.

SUPPLEMENTAL BENEFITS

Per hour:	\$ 20.49
-----------	----------

OVERTIME PAY

Exterior work only See (B, E, E2, Q) on OVERTIME PAGE.

All other work See (B, E, Q) on OVERTIME PAGE.

HOLIDAY

Paid:	See (1) on HOLIDAY PAGE
Overtime:	See (5, 6) on HOLIDAY PAGE

REGISTERED APPRENTICES

Wages per hour:

Hour terms at the following dollar amounts:

0	to 1000	to 2000	to 3000	to 4000	to 4700	to 5400	to 6000	to 7000	to 8000
\$ 12.00	\$ 14.00	\$ 15.00	\$ 16.00	\$ 17.00	\$ 18.00	\$ 19.00	\$ 20.00	\$ 21.00	

Supplemental benefits per hour:

Hour terms at the following dollar amounts:

0	to 4000	to 4700	to 5400	to 6000	to 8000
\$ 2.50	\$ 3.50	\$ 4.50	\$ 5.50	\$ 7.50	

3-9-Pltr

Mason - Building

11/01/2019

JOB DESCRIPTION Mason - Building

DISTRICT 5

ENTIRE COUNTIES

Erie, Niagara

PARTIAL COUNTIES

Cattaraugus: Only the Township of Perrysburg and the Village of Gowanda.

WAGES

Per Hour:	07/01/2019
Building:	
Bricklayer	\$ 31.49
Stone Mason	31.49
Tuck Pointer	31.49

Four (4), ten (10) hour days may be worked at straight time during a week, Monday thru Thursday. Friday may be used as a make-up day.

NOTE - In order to use the '4 Day/10 Hour Work schedule', as your normal schedule, you must submit an 'Employer Registration for Use of 4 Day/10 Hour Work Schedule,' form PW30.1; and there must be a dispensation of hours in place on the project. If the PW30.1 is not submitted you may be liable for overtime payments for work over 8 hours per day.

SUPPLEMENTAL BENEFITS

Per hour:

Journeyman \$ 28.34

OVERTIME PAY

See (B,E,E2*,Q) on OVERTIME PAGE

*Note - Or other conditions beyond the employer's control such as fire or natural disaster.

HOLIDAY

Paid: See (1) on HOLIDAY PAGE
Overtime: See (5, 6) on HOLIDAY PAGE

REGISTERED APPRENTICES

Wages per hour:

1250 hour terms at the following wage:

1st	2nd	3rd	4th
\$ 24.87	\$ 25.39	\$ 27.12	\$ 29.63

Supplemental benefits per hour:

1st	2nd	3rd	4th
\$ 10.95	\$ 16.43	\$ 20.70	\$ 24.20

5-3B-Z3

Mason - Building / Heavy&Highway

11/01/2019

JOB DESCRIPTION Mason - Building / Heavy&Highway

DISTRICT 3

ENTIRE COUNTIES

Erie

PARTIAL COUNTIES

Cattaraugus: Only the Township of Perrysburg and the Village of Gowanda.

WAGES

Per hour: 07/01/2019 07/01/2020
Additional
Cement Mason \$ 30.00 \$ 1.25
Additional \$0.25 per hr for swing scaffold or exterior scaffold 42' or higher.
Additional \$1.00 per hr when required to wear respirator.

SUPPLEMENTAL BENEFITS

Per hour: \$ 31.67

OVERTIME PAY

See (B, E, Q, V) on OVERTIME PAGE

HOLIDAY

Paid: See (1) on HOLIDAY PAGE
Overtime: See (5, 6) on HOLIDAY PAGE

REGISTERED APPRENTICES

Wages per hour:

750 hour terms at the following dollar amounts:

1st	2nd	3rd	4th	5th	6th
\$ 15.00	\$ 16.50	\$ 19.50	\$ 22.50	\$ 25.50	\$ 28.50

Supplemental benefits per hour:

1st	2nd	3rd	4th	5th	6th
\$ 8.41	\$ 11.36	\$ 11.23	\$ 14.42	\$ 16.47	\$ 19.69

3-111Erie

Mason - Heavy&Highway

11/01/2019

JOB DESCRIPTION Mason - Heavy&Highway

DISTRICT 5

ENTIRE COUNTIES

Allegany, Broome, Chautauqua, Chemung, Chenango, Cortland, Delaware, Genesee, Livingston, Monroe, Ontario, Orleans, Otsego, Schuyler, Seneca, Steuben, Tioga, Tompkins, Wayne, Wyoming, Yates

PARTIAL COUNTIES

Cattaraugus: Entire county except in the Township of Perrysburg and the Village of Gowanda only the Bricklayer classification applies.
Erie: Only the Bricklayer classification applies.

Niagara: Only the Bricklayer classification applies.

WAGES

Per hour:	07/01/2019	07/01/2020	07/01/2021
Heavy & Highway:		Additional	Additional
Cement Mason	\$ 31.28	\$ 1.00	\$ 1.15
Bricklayer	31.28		

Four (4), ten (10) hour days may be worked at straight time during a week, Monday thru Thursday. Friday may be used as a make-up day.

NOTE - In order to use the '4 Day/10 Hour Work schedule', as your normal schedule, you must submit an 'Employer Registration for Use of 4 Day/10 Hour Work Schedule,' form PW30.1; and there must be a dispensation of hours in place on the project. If the PW30.1 is not submitted you may be liable for overtime payments for work over 8 hours per day.

SUPPLEMENTAL BENEFITS

Per hour:

Journeyman \$ 22.23

OVERTIME PAY

See (B, E, E2, Q) on OVERTIME PAGE

HOLIDAY

Paid: See (1) on HOLIDAY PAGE
 Overtime: See (5, 6) on HOLIDAY PAGE

REGISTERED APPRENTICES

Wages per hour:

1500 hour terms at the following percentage of Journeyman's wage:

1st	2nd	3rd	4th
50%	60%	70%	80%

Supplemental benefits per hour:

1st term	\$ 13.93
2nd - 4th term	22.23

5-3h

Mason - Tile Finisher 11/01/2019

JOB DESCRIPTION Mason - Tile Finisher

DISTRICT 5

ENTIRE COUNTIES

Chautauqua

PARTIAL COUNTIES

Allegany: Entire County with the exception of the Towns of Alfred, Almond, Andover and Burns.
 Cattaraugus: With the exception of the Township of Perrysburg and the Village of Gowanda.

WAGES

Per hour:	07/01/2019	07/01/2020	07/01/2021
Building:		Additional	Additional
Marble, Slate, Terrazzo and Tile Finisher	\$ 27.00	\$ 1.00	\$ 1.15

Four (4), ten (10) hour days may be worked at straight time during a week, Monday thru Thursday. Friday may be used as a make-up day.

NOTE - In order to use the '4 Day/10 Hour Work schedule', as your normal schedule, you must submit an 'Employer Registration for Use of 4 Day/10 Hour Work Schedule,' form PW30.1; and there must be a dispensation of hours in place on the project. If the PW30.1 is not submitted you may be liable for overtime payments for work over 8 hours per day.

SUPPLEMENTAL BENEFITS

Per hour: \$ 17.81

OVERTIME PAY

See (B,E,E2*,Q) on OVERTIME PAGE

*Note - Or other conditions beyond the employer's control such as fire or natural disaster.

HOLIDAY

Paid: See (1) on HOLIDAY PAGE
 Overtime: See (5, 6) on HOLIDAY PAGE

REGISTERED APPRENTICES

Wages per hour:

1st and 2nd term 1200 hours and 3rd term 1300 hours at the following percentage of Journeyman's rate:

1st	2nd	3rd
\$ 18.03	\$ 21.37	\$ 22.28

Supplemental benefits per hour:

1st	2nd	3rd
\$ 8.78	\$ 9.94	\$ 13.53

5-3TF - Z2

Mason - Tile Finisher

11/01/2019

JOB DESCRIPTION Mason - Tile Finisher

DISTRICT 5

ENTIRE COUNTIES

Erie, Niagara, Orleans

PARTIAL COUNTIES

Cattaraugus: Only the Township of Perrysburg and the Village of Gowanda.

WAGES

Per hour: 07/01/2019

Building:

Marble, Slate, Terrazzo and Tile Finisher \$ 29.30

Four (4), ten (10) hour days may be worked at straight time during a week, Monday thru Thursday. Friday may be used as a make-up day.

NOTE - In order to use the '4 Day/10 Hour Work schedule', as your normal schedule, you must submit an 'Employer Registration for Use of 4 Day/10 Hour Work Schedule,' form PW30.1; and there must be a dispensation of hours in place on the project. If the PW30.1 is not submitted you may be liable for overtime payments for work over 8 hours per day.

SUPPLEMENTAL BENEFITS

Per hour: \$ 16.13

OVERTIME PAY

See (B,E,E2*,Q) on OVERTIME PAGE

*Note - Or other conditions beyond the employer's control such as fire or natural disaster.

HOLIDAY

Paid: See (1) on HOLIDAY PAGE
Overtime: See (5, 6) on HOLIDAY PAGE

REGISTERED APPRENTICES

Wages per hour:

1200 hours 1st and 2nd term and 1300 hours 3rd term at the following wage:

1st	2nd	3rd
\$ 18.74	\$ 21.31	\$ 24.13

Supplemental benefits per hour:

1st	2nd	3rd
\$ 8.44	\$ 10.43	\$ 12.17

5-3TF - Z3

Mason - Tile Setter

11/01/2019

JOB DESCRIPTION Mason - Tile Setter

DISTRICT 5

ENTIRE COUNTIES

Erie, Niagara, Orleans

PARTIAL COUNTIES

Cattaraugus: Only in the Township of Perrysburg and the Village of Gowanda.

WAGES

Per hour: 07/01/2019

Building:

Marble, Slate, Terrazzo and Tile Setter \$ 31.97

Four (4), ten (10) hour days may be worked at straight time during a week, Monday thru Thursday. Friday may be used as a make-up day.

NOTE - In order to use the '4 Day/10 Hour Work schedule', as your normal schedule, you must submit an 'Employer Registration for Use of 4 Day/10 Hour Work Schedule,' form PW30.1; and there must be a dispensation of hours in place on the project. If the PW30.1 is not submitted you may be liable for overtime payments for work over 8 hours per day.

SUPPLEMENTAL BENEFITS

Per hour: \$ 27.36

OVERTIME PAY

See (B,E,E2*,Q) on OVERTIME PAGE

*Note - Or other conditions beyond the employer's control such as fire or natural disaster.

HOLIDAY

Paid: See (1) on HOLIDAY PAGE

Overtime: See (5, 6) on HOLIDAY PAGE

REGISTERED APPRENTICES

Wages per hour:

1250 hour terms at the following wage:

1st	2nd	3rd	4th
\$ 24.65	\$ 25.12	\$ 26.89	\$ 29.93

Supplemental benefits per hour:

1st	2nd	3rd	4th
\$ 10.87	\$ 16.35	\$ 20.53	\$ 23.45

5-3TS - Z3

Mason - Tile Setter

11/01/2019

JOB DESCRIPTION Mason - Tile Setter

DISTRICT 5

ENTIRE COUNTIES

Chautauqua

PARTIAL COUNTIES

Allegany: Entire County with the exception of the towns of Alfred, Almond, Andover and Burns.
 Cattaraugus: With the exception of the Township of Perrysburg and the Village of Gowanda.

WAGES

Per hour:	07/01/2019	07/01/2020	07/01/2021
Building:		Additional	Additional
Marble, Slate, Terrazzo and Tile Setter	\$ 32.19	\$ 1.00	\$ 1.15

Four (4), ten (10) hour days may be worked at straight time during a week, Monday thru Thursday. Friday may be used as a make-up day.

NOTE - In order to use the '4 Day/10 Hour Work schedule', as your normal schedule, you must submit an 'Employer Registration for Use of 4 Day/10 Hour Work Schedule,' form PW30.1; and there must be a dispensation of hours in place on the project. If the PW30.1 is not submitted you may be liable for overtime payments for work over 8 hours per day.

SUPPLEMENTAL BENEFITS

Per hour:

Journeyman \$ 18.16

OVERTIME PAY

See (B,E,E2*,Q) on OVERTIME PAGE

*Note - Or other conditions beyond the employer's control such as fire or natural disaster.

HOLIDAY

Paid: See (1) on HOLIDAY PAGE

Overtime: See (5, 6) on HOLIDAY PAGE

REGISTERED APPRENTICES

Wages per hour:

One year terms at the following percentage of Joureyman's wage:

1st	2nd	3rd	4th
\$ 20.14	\$ 23.24	\$ 26.32	\$ 29.42

Supplemental benefits per hour:

1st	2nd	3rd	4th
\$ 9.99	\$ 11.95	\$ 13.92	\$ 15.88

5-3TS - Z2

Millwright

11/01/2019

JOB DESCRIPTION Millwright

DISTRICT 7

ENTIRE COUNTIES

Allegany, Broome, Cattaraugus, Cayuga, Chautauqua, Herkimer, Madison, Seneca, Tioga, Yates

WAGES

Per Hour	07/01/2019	07/01/2020
		Additional
Building	\$ 28.18	\$ 1.60
Heavy & Highway*	30.18	1.60

*Effective 5/1/2019, all Heavy and Highway Millwright construction will be paid at the rate indicated above.

NOTE - ADDITIONAL PREMIUMS PAID FOR THE FOLLOWING WORK LISTED BELOW (amount subject to any overtime premiums):

- Certified Welders shall receive \$1.75 per hour in addition to the current Millwright's rate, provided he/she is directed to perform certified welding.
- On building projects, if a work site has been declared a hazardous site by the Owner and the use of protective gear (including, as a minimum, air purifying canister-type chemical respirators) are required, then that employee shall receive a \$1.50 premium per hour.
- H/H work performed on hazardous waste sites where employees are required to wear protective gear shall receive an additional \$2.00 per hour over the Millwright H/H rate for all hours worked on the day protective gear was worn
- An employee performing the work of a machinist shall receive \$2.00 per hour in addition to the current Millwright's rate. For the purpose of this premium to apply, a "machinist" is a person who uses a lathe, Bridgeport, milling machine or similar type of tool to make or modify parts.
- When performing work underground at 500 feet and below, the employee shall receive an additional \$0.50. This amount will increase to \$1.00 on 7/1/2020.

SUPPLEMENTAL BENEFITS

Per hour:

Journeyman	\$ 22.05
------------	----------

OVERTIME PAY

See (B, E, *E2, Q) on OVERTIME PAGE

*Note - Saturday may be used as a make-up day and worked at the straight time rate of pay during a work week when conditions such as weather, power failure, fire, or natural disaster prevent the performance of work on a regular scheduled work day.

HOLIDAY

Paid: See (1) on HOLIDAY PAGE
 Overtime: See (5, 6) on HOLIDAY PAGE

NOTE: Any holiday that falls on Sunday shall be observed the following Monday. Any holiday that falls on a Saturday shall be observed the preceding Friday.

REGISTERED APPRENTICES

WAGES: (1) year terms at the following percentage of Journeyman's wage.

1st	2nd	3rd	4th
60%	70%	80%	90%

SUPPLEMENTAL BENEFITS per hour worked:

Appr. 1st year	\$ 10.50
Appr. 2nd year	18.59
Appr. 3rd year	19.74
Appr. 4th year	20.90

7-1163 Zone 2

Operating Engineer - Building

11/01/2019

JOB DESCRIPTION Operating Engineer - Building

DISTRICT 12

ENTIRE COUNTIES

Cattaraugus, Chautauqua, Erie, Orleans, Wyoming

PARTIAL COUNTIES

Genesee: Only that portion of the county that lies west of a line down the center of Route 98 excluding that area that lies within the City of Batavia.

WAGES

CLASS A: Air Hoist, All Boom Type Equipment, All Pans and Carry-Alls, Archer Hoist, Asphalt Curb and Gutter Machines, Asphalt Roller, Asphalt Spreader or Paver, Automatic Fine Grade Machine (CMI or similar, first and second operator), Backhoe and Pullhoe, Backhoe and Pullhoe (tractor mounted, rubber tired), Back Filling Machine, Belt Placer (CMI or similar type), Bending Machine (Pipe), Bituminous Spreader and Mixer, Blacktop Plants (Automated and Non-automated), Blast or Rotary Drill (Truck or Track Mounted), Blower for Burning Brush, Boiler (when used for power), Boom Truck (excluding pick-up and delivery), Boring Machine, Bulldozer, Cableway, Cage Hoist, Caisson Auger, Central Mix Plant (and all concrete batching plants), Cherry Picker, Concrete Cleaning Decontamination Machine Operator, Concrete Curb and Gutter Machine, Concrete Curing Machine, Concrete Cutters (Vermeer or Similar Type), Concrete Mixer (over 1/2 cu yd.), Concrete Pavement Spreaders and Finishers, Concrete Paver, Concrete Pump, Conveyor, Core Drill, Crane, Crusher, Decon of Equipment, Derrick, Dragline, Dredge, Drill Rig (Tractor Mounted), Dual Drum Paver, Electric Pump used in conjunction with Well Point Systems, Elevating Grader (self propelled or towed), Elevator, Excavator (all purpose, hydraulically operated), Farm Tractor with Accessories, Fine Grade Machine, Forklift, Front End Loader, Generator (10 outlets or more), Gradall, Grader, Grout or Guniting Machine, Head Tower, Heavy Equipment Robotics Operator/Mechanic, Helicopter (when used for hoisting), Hoist (one drum), Hoisting Engine, Horizontal Directional Drill Locator, Horizontal Directional Drill Operator, Hydraulic Boom, Hydraulic Hammer (self-propelled), Hydraulic Pipe Jack Machine (or similar type machine), Hydraulic Rock Expander (or similar type machine), Hydraulic System Pumps, Hydro Crane, Hydro Hammer (or similar type), Industrial Tractor, Jersey Spreader, Kolman Plant Loader (and similar type loaders), Laser Screed, Locomotive, Lubrication Truck, Maintenance Engineer, Maintenance, Lubrication Unit or Truck, Mine Hoist, Mixer for Stabilized Base (self-propelled), Monorail, Motorized Hydraulic Pin Puller, Motorized Hydraulic Seeder, Mucking Machine, Mulching Machine, Multiple Drum Hoist (more than one drum in use), Overhead Crane, Peine Crane (or similar type), Pile Driver, Plant Engineer, Pneumatic Mixer, Post Hole Digger and Driver, Power Broom, Pumpcrete, Push Button Hoist, Push or Snatch Cat, Quarry Master or equivalent, Road Widener, Rock Bit Sharpener (all types), Roller (all), Rolling Machine (pipe), Rotomill, Scissors Trucks, Lift, or Boom Lift of any type (when used for hoisting), Scoopmobile, Shovel, Sideboom, Skidsteer/Bobcat (Similar Type), Skimmer, Slip Form Paver (CMI or similar type), Snorkel/Vacuum Truck, Strato-Tower, Stump Chipping Machine, Tire Truck and Drivers performing tire repair (exclude outside vendor), Towed Roller, Tractor Drawn Belt-Type Grader/Loader, Tractor Shovel, Tractor with Towed Accessories, Tractor (when using winch power), Tractors, Trencher, Truck Crane, Truck Mechanic and Helper (exclude Teamsters when repairing their own trucks), Tunnel Shovel, Tube Finisher (CMI and similar type), Ultra High Pressure Waterjet Cutting Tool System Operator/Mechanic, Vacuum Blasting Machine Operator/Mechanic, Vibratory Compactor, Vibro Tamp, Well Drilling Machine, Well Point, Winch, Winch Truck with A Frame.

CLASS B: Aggregate Bin, Aggregate Plant, Apprentice Engineer, Apprentice Engineer Driver, Articulated Off Road Material Hauler, Boiler (used in conjunction with production), CMI and similar type Concrete Spreads (Apprentice Engineer), Cement Bin, Chipping Machine and Chip Spreader, Compressors (4 or less), Compressors (any size, but subject to other provisions for Compressors, Dust Collectors, Generators, Mechanical Heaters, Pumps, Welding Machines - four of any type or combination), Concrete Mixer (1/2 cu. yd. and under), Fireman, Form Tamper, Form Trucks (excluding Teamster or delivery), Fuel Truck or Drivers (exclude Teamster or delivery), Heaters, Heating Boiler (used for temporary heat), Helper on Lubrication Unit or Truck, Jeep Trencher, Power Heaterman, Power Plant in excess of 10 K.W., Pumps, Revinus Widener, Steam Boilers (if manning or license by local law is required), Steam Cleaner (when used for cleaning equipment on the job site), Welding Machine (1 machine over 300 amps or 2 or 3 machines regardless of amps).

Operating Engineer- Building:

Per hour:	07/01/2019
Class A	\$ 37.21
Class B	32.73
Crane(Up to 60 Tons)	38.71
" (61 to 199 Tons)	40.71
" (200 to 399 Tons)	41.21
" (400 Tons or more)	41.71

Additional \$5.00/hr. for Any Tower Crane
Additional \$2.50/hr. for Hazardous Work Site
Additional \$1.00/hr. for Tunnel Work

SUPPLEMENTAL BENEFITS

Per Hour:

Journeyman \$ 29.85**

**Note: For Overtime Hours \$21.65 of this amount is paid a straight time, the remaining balance of \$8.20 is paid at the same premium as the wage.

OVERTIME PAY

See (B, E, *E2, P, **V) on OVERTIME PAGE

* Only Saturdays between October 15th and April 15th.

HOLIDAY

Paid: See (5, 6) on HOLIDAY PAGE
Overtime: See (5, 6) on HOLIDAY PAGE

REGISTERED APPRENTICES

Wages per hour:
1 year Terms

1st	2nd	3rd	4th
\$27.05	\$27.94	\$28.82	\$29.71

Supplemental benefits Per Hour:
 All Apprentices \$28.95**

**Note: For Overtime Hours \$21.65 of this amount to be paid a straight time rate remaining balance of \$7.30 is paid at same premium as the wage.

12-17b

Operating Engineer - Heavy&Highway **11/01/2019**

JOB DESCRIPTION Operating Engineer - Heavy&Highway

DISTRICT 12

ENTIRE COUNTIES

Cattaraugus, Chautauqua, Erie, Orleans, Wyoming

PARTIAL COUNTIES

Genesee: Only that portion of the county that lies west of a line down the center of Route 98 excluding that area that lies within the City of Batavia.

WAGES

CLASS A: Air Hoist, All Boom Type Equipment, All Pans and Carry-alls, Asphalt Curb and Cutter Machines, Asphalt Roller, Asphalt Spreader or Paver, Automatic Fine Grade Machine (CMI or similar, first and second operator), Backhoe and Pullhoe (all), Back Filling Machine, Belt Placer (CMI or similar type), Bending Machine (pipe), Bituminous Spreader and Mixer, Blacktop Plant (all), Blast or Rotary Drill (Truck or Track Mounted), Blower for Burning Brush, Boiler (when used for power), Boom Truck, Boring Machine, Bulldozer, Cableway, Cage Hoist, Caisson Auger, Central Mix Plant (and all Concrete Batching Plants), Cherry Picker, Concrete Cleaning Decontamination Machine, Concrete Curb and Gutter Machine, Concrete Curing Machine, Concrete Mixer (over 1/2 cu. yd.), Concrete Pavement Spreaders and Finishers, Concrete Paver, Concrete Pump, Concrete Saw (self propelled), Conveyor, Convoing Vehicles Convoing Engineer's Equipment, Core Drill, Crane, Crusher, Decontamination of Equipment, Derrick, Dragline, Dredge, Drill Rig (Tractor Mounted), Dual Drum Paver, Electric Pump used in conjunction with Well Point Systems, Elevating Grader (self propelled or towed), Elevator, Excavator (all purpose, hydraulically operated), Farm Tractor with Accessories, Fine Grade Machine, Forklift, Front End Loader, Gradall, Grader, Grout or Guniting Machine, Head Tower, Heavy Equipment Robotics Operator/Mechanic, Hoist (all types), Hoisting Engine, Horizontal Directional Drill Locator, Horizontal Directional Drill Operator, Hydraulic Boom, Hydraulic Hammer (self propelled), Hydraulic Pipe Jack Machine, (or similar type machine), Hydraulic Rock Expander (or similar type machine), Hydraulic System Pumps, Industrial Tractor, Jersey Spreader, Kolman Plant Loader (and similar type Loaders), Laser Screed, Locomotive, Log Skidder (similar type), Maintenance Engineer, Maintenance, Lubrication Unit or Truck, Mine Hoist, Mixer for Stabilized Base (self propelled), Monorail, Motorized Hydraulic Pin Puller, Motorized Hydraulic Seeder, Mucking Machine, Mulching Machine, Overhead Crane, Parts Chasing, Peine Crane (or similar type), Pile Driver, Plant Engineer, Pneumatic Mixer, Post Hole Digger and Post Driver, Power Broom, Pump Crete, Push Button Hoist, Push or Snatch Cat, Quarry Master (or equivalent), Road Widener, Rock Bit Sharpener (all types), Roller (all), Rolling Machine (Pipe), Rotomill, Scoopmobile, Shovel, Side Boom, Skidsteer/Bobcat (similar type), Skimmer, Slip Form Paver (CMI or similar, first and second operator), Snorkel/Vacuum Truck, Strato-Tower, Tire Truck & Repair, Towed Roller, Tractor Drawn Belt-Type Grader/Loader, Tractor Shovel, Tractor with Towed Accessories, Tractors (when using winch power), Trencher, Truck Crane, Tug Boats, Tunnel Shovel, Tube Finisher (CMI and similar), Vacuum Blasting Machine Operator/Mechanic, Vibratory Compactor, Vibro Tamp, Waterjet Cutting Tool System Operator/Mechanic (Ultra High Pressure), Well Drilling Machine, Well Point, Winch, Winch Truck with A Frame.

CLASS B: Aggregate Bin, Aggregate Plant, Apprentice Engineer, Apprentice Engineer Driver, Articulated Off Road Material Hauler, CMI and similar type Concrete Spreads (Apprentice Engineer), Cement Bin, Chipping Machine and Chip Spreader, Compressors (4 or less), Compressors: any size, but subject to other provisions for Compressors, Dust Collectors, Generators, Mechanical Heaters, Pumps, Welding Machines (four of any type or combination), Concrete Mixer (1/2 cu. yd. and under), Fireman, Form Tamper, Fuel Truck, Heating Boiler (used for temporary heat), Helper on Lubrication Unit or Truck, Jeep Trencher, Power Heaterman, Power Plant in excess of 10 K.W., Pumps (4" or over), Revinus Widener, Steam Cleaner, Stump Chipping Machine, Welding Machine (1 machine over 300 amps or 2 or 3 machines regardless of amps).

Operating Engineer- Heavy/Highway, Sewer/Water, Tunnel:

Per hour:	07/01/2019
Class A	\$ 38.99
Class B	34.49
Crane(boom over 100ft)	39.74
" (boom over 200ft)	39.99
" (boom over 300ft)	40.49

- Additional \$3.00/hr. for Lattice Boom
- Additional \$3.00/hr. for Hydraulic Crane over 60 tons
- Additional \$2.50/hr. for Hazardous Work Site
- Additional \$1.00/hr. for Tunnel Work
- Additional \$3.00/hr. for Mandated Off-Shift Work

SUPPLEMENTAL BENEFITS

Per hour:

Journeyman \$ 31.16*

*Note: For Overtime Hours \$23.46 of the amount paid at straight time, the remaining balance of \$7.70 is paid at the same premium as the wage.

OVERTIME PAY

See (B, E, Q, T, *V) on OVERTIME PAGE

HOLIDAY

Paid: See (*5, **6) on HOLIDAY PAGE

Overtime: See (**5, ****6) on HOLIDAY PAGE

*, ** NOTE: If Holiday falls on a Sunday it will be celebrated on Monday

, * NOTE: If employee works that Monday use "T" under Overtime Pay.

REGISTERED APPRENTICES

Wages per hour:

Apprentices at 1 year terms

1st	2nd	3rd	4th
\$31.49	\$32.49	\$33.49	\$34.49

Supplemental Benefits

All Apprentices \$30.76*

Note: For Overtime Hours \$23.46 of this amount is paid at straight time , the remaining balance of \$7.30 is paid at the same premium as the wage.

12-17 hh/sw/t

Operating Engineer - Survey Crew

11/01/2019

JOB DESCRIPTION Operating Engineer - Survey Crew

DISTRICT 12

ENTIRE COUNTIES

Cattaraugus, Chautauqua, Erie, Orleans, Wyoming

PARTIAL COUNTIES

Genesee: Only that portion of the county that lies west of a line down the center of Route 98 excluding that area that lies within the City of Batavia.

WAGES

These rates apply to Building and Heavy Highway.

Per hour:

SURVEY CLASSIFICATIONS:

Party Chief - One who directs a survey party.

Instrument Person - One who operates the surveying instruments.

Rod Person - One who holds the rods and assists the Instrument Person.

07/01/2019

Party Chief	\$ 41.51
Instrument Person	39.15
Rod Person	27.10

Additional \$3.00 per hr. for work in a Tunnel.

Additional \$2.50 per hr. for EPA or DEC certified toxic or hazardous waste work.

SUPPLEMENTAL BENEFITS

Per hour worked:

Journeyman \$ 26.80

OVERTIME PAY

See (B, E, P, T) on OVERTIME PAGE

HOLIDAY

Paid: See (5, 6) on HOLIDAY PAGE

Overtime: See (5, 6) on HOLIDAY PAGE

REGISTERED APPRENTICES

WAGES: 1000 hour terms based on the Percentage of Rod Person wage:

07/01/2019

0-1000 Hrs	60%
1001-2000 Hrs	70%
2001-3000 Hrs	80%

SUPPLEMENTAL BENEFITS per hour worked:

0-1000 Hrs	\$ 16.21
1001-2000 Hrs	18.92
2001-3000 Hrs	21.63

12-17D Sur

Operating Engineer - Survey Crew - Consulting Engineer

11/01/2019

JOB DESCRIPTION Operating Engineer - Survey Crew - Consulting Engineer

DISTRICT 12

ENTIRE COUNTIES

Cattaraugus, Chautauqua, Erie, Orleans, Wyoming

PARTIAL COUNTIES

Genesee: Only that portion of the county that lies west of a line down the center of Route 98 excluding that area that lies within the City of Batavia.

WAGES

These rates apply to feasibility and preliminary design surveying, line of grade surveying for inspection or supervision of construction when performed under a Consulting Engineer Agreement.

Per hour:

SURVEY CLASSIFICATIONS:

Party Chief - One who directs a survey party.

Instrument Person - One who operates the surveying instruments.

Rod Person - One who holds the rods and assists the Instrument Person.

07/01/2019

Party Chief	\$ 41.51
Instrument Person	39.15
Rod Person	27.10

SUPPLEMENTAL BENEFITS

Per hour worked:

Journeyman	\$ 26.80
------------	----------

OVERTIME PAY

See (B, E, P, T) on OVERTIME PAGE

HOLIDAY

Paid: See (5, 6) on HOLIDAY PAGE

Overtime: See (5, 6) on HOLIDAY PAGE

REGISTERED APPRENTICES

WAGES: 1000 hour terms based on the Percentage of Rod Persons Wage:

07/01/2019

0-1000	60%
1001-2000	70%
2001-3000	80%

SUPPLEMENTAL BENEFITS per hour worked:

0-1000	\$ 16.21
1001-2000	18.92
2001-3000	21.63

12-17D Con Eng

Painter

11/01/2019

JOB DESCRIPTION Painter

DISTRICT 3

ENTIRE COUNTIES

Allegany, Erie, Genesee, Niagara, Orleans, Wyoming

PARTIAL COUNTIES

Cattaraugus: Entire County except the Townships of Conewango, Leon, Napoli, New Albion, Randolph and South Valley.

Chautauqua: Only the Townships of Awkright, Dunkirk, Hanover, Pomfret, Portland, Sheridan and Villenova.

Livingston: Only the Townships of North Dansville, Nunda, Ossian, Portage, Sparta, Spring Water and West Sparta.

Steuben: Only the Townships of Avoca, Canisteo, Cohocton, Dansville, Fremont, Greenwood, Hartsville, Hornellsville, Howard, Jasper, Prattsburg, Pulteney, Troupsburg, Tuscarora, Urbana, Wayland, Wayne, Woodhull, West Union, Wheeler, and the City of Hornell.

WAGES

Per hour:	07/01/2019	05/01/2020
		Additional
Basic Rate (Brush & Roll)	\$ 26.45	\$ 1.00
Spray painting, wallcovering	26.45	1.00
Abrasive and hydroblasting	26.45	1.00
Taping/DryWall Finisher	26.95	1.00
Skeleton Steel*	27.20	1.00

* Skeleton Steel: No floors, walls or ceiling are constructed, including radio and television towers, flagpoles, smokestacks, cranes and the abatement of coatings with lead, asbestos and/or arsenic, etc. All work within the confines of a plant shall be paid the skeleton steel rate (except in-plant tank work (see Tank Rate)).

Four (4), ten (10) hour days may be worked at straight time during a week, Monday thru Thursday. Friday may be used as a make-up day.

NOTE - In order to use the '4 Day/10 Hour Work schedule', as your normal schedule, you must submit an 'Employer Registration for Use of 4 Day/10 Hour Work Schedule,' form PW30.1; and there must be a dispensation of hours in place on the project. If the PW30.1 is not submitted you may be liable for overtime payments for work over 8 hours per day.

SUPPLEMENTAL BENEFITS

Per hour:
 \$ 25.34

OVERTIME PAY

Exterior work only See (B, E4, F*, R) on OVERTIME PAGE.

All other work See (B, F*, R) on OVERTIME PAGE.

* Note - Saturday is payable at straight time if the employee misses work, except where a doctor's or hospital verification of illness is produced Monday through Friday when work was available to the employee.

HOLIDAY

Paid: See (1) on HOLIDAY PAGE
 Overtime: See (5, 6) on HOLIDAY PAGE

REGISTERED APPRENTICES

Wages per hour:

Painter/Decorator: 750 hour terms at the following percentage of Journeyman's Basic wage rate:

1st	2nd	3rd	4th	5th	6th	7th	8th
50%	55%	60%	65%	70%	75%	80%	90%

Taper/Drywall Finisher: 750 hour terms at the following percentage of Journeyman's Taper wage:

1st	2nd	3rd	4th	5th	6th
50%	55%	60%	65%	75%	85%

Supplemental benefits per hour:

Painter/Decorator and Taper/Drywall Finisher:

1st	2nd	3rd	4th	5th	6th	7th	8th
\$ 2.30	\$ 4.30	\$ 5.30	\$ 5.80	\$ 6.30	\$ 6.80	\$ 7.30	\$ 7.55

3-4-Buf, Nia, Olean

Painter

11/01/2019

JOB DESCRIPTION Painter

DISTRICT 3

ENTIRE COUNTIES

Allegany, Broome, Cattaraugus, Cayuga, Chautauqua, Chemung, Chenango, Cortland, Delaware, Erie, Genesee, Herkimer, Jefferson, Lewis, Livingston, Madison, Monroe, Niagara, Oneida, Onondaga, Ontario, Orleans, Oswego, Otsego, Schuyler, Seneca, St. Lawrence, Steuben, Tioga, Tompkins, Wayne, Wyoming, Yates

WAGES

Per hour:	07/01/2019	05/01/2020
		Additional

Bridge	\$ 38.50	\$ 1.05
Tunnel	38.50	1.05
Tank*	36.50	1.05

For Bridge Painting Contracts, ALL WORKERS on and off the bridge (including Flagmen) are to be paid Painter's Rate; the contract must be ONLY for Bridge Painting.

Tank rate applies to indoor and outdoor tanks, tank towers, standpipes, digesters, waste water treatment tanks, chlorinator tanks, etc. Covers all types of tanks including but not limited to steel tanks, concrete tanks, fiberglass tanks, etc.

Note an additional \$2.00 per hour is required when the contracting agency or project specification requires any shift to start prior to 6:00am or after 12:00 noon.

SUPPLEMENTAL BENEFITS

Per hour: \$ 28.70

OVERTIME PAY

Exterior work only See (B, E4, F*, R) on OVERTIME PAGE.

All other work See (B, F*, R) on OVERTIME PAGE.

*Note - Saturday is payable at straight time if the employee misses work, except where a doctor's or hospital verification of illness is produced Monday through Friday when work was available to the employee.

HOLIDAY

Paid: See (1) on HOLIDAY PAGE
 Overtime: See (5, 6) on HOLIDAY PAGE

REGISTERED APPRENTICES

Wages per hour:

750 hour terms at the following percentage of Journeyman's wage rate:

1st	2nd	3rd	4th	5th	6th
50%	55%	60%	65%	75%	85%

Supplemental benefits per hour:

1st & 2nd terms	\$ 5.45
3rd & 4th terms	5.45
5th & 6th terms	6.45

3-4-Bridge, Tunnel, Tank

Painter 11/01/2019

JOB DESCRIPTION Painter

DISTRICT 3

ENTIRE COUNTIES

PARTIAL COUNTIES

Cattaraugus: Only the Townships of Conewango, Leon, Napoli, New Albion, Randolph and South Valley.

Chautauqua: Only the Townships of Busti, Carroll, Charlotte, Chautauqua, Cherry Creek, Clymer, Ellery, Ellicott, Ellington, French Creek, Gerry, Harmony, Kiantone, Mina, North Harmony, Poland, Ripley, Sherman, Stockton, Westfield and the City of Jamestown.

WAGES

Per hour:	07/01/2019	05/01/2020
		Additional
Brush & Roller, taping,	\$ 26.15	\$ 1.00
wallcovering, swing & bosun	26.15	1.00
under 3 stories or under 35 ft	26.15	1.00
Swing & bosun over 3 stories or	26.40	1.00
over 35 feet, steel painting	26.40	1.00
All spraying, steam cleaning &	26.80	1.00
sandblasting, all toxic coating	26.80	1.00
Stacks	27.45	1.00

Four (4), ten (10) hour days may be worked at straight time during a week, Monday thru Thursday. Friday may be used as a make-up day.

NOTE - In order to use the '4 Day/10 Hour Work schedule', as your normal schedule, you must submit an 'Employer Registration for Use of 4 Day/10 Hour Work Schedule,' form PW30.1; and there must be a dispensation of hours in place on the project. If the PW30.1 is not submitted you may be liable for overtime payments for work over 8 hours per day.

SUPPLEMENTAL BENEFITS

Per hour:

\$ 18.08

OVERTIME PAY

Exterior work only See (B, E4, F*, R) on OVERTIME PAGE.

All other work See (B, F*, R) on OVERTIME PAGE.

* Note - Saturday is payable at straight time if the employee misses work, except where a doctor's or hospital verification of illness is produced Monday through Friday when work was available to the employee.

HOLIDAY

Paid: See (1) on HOLIDAY PAGE

Overtime: See (5, 6) on HOLIDAY PAGE

REGISTERED APPRENTICES

Wages per hour:

Painter/Decorator: 750 hour terms at the following percentage of Journeyman's Basic wage rate:

1st	2nd	3rd	4th	5th	6th	7th	8th
50%	55%	60%	65%	70%	75%	80%	90%

Taper/Drywall Finisher: 750 hour terms at the following percentage of Journeyman's Taper wage:

1st	2nd	3rd	4th	5th	6th
50%	55%	60%	65%	75%	85%

Supplemental benefits per hour:

Painter/Decorator and Taper/Drywall Finisher:

1st	2nd	3rd	4th	5th	6th	7th	8th
\$ 2.30	\$ 4.30	\$ 5.30	\$ 5.80	\$ 6.30	\$ 6.80	\$ 7.30	\$ 7.55

3-4-Jamestown

Painter - Metal Polisher

11/01/2019

JOB DESCRIPTION Painter - Metal Polisher

DISTRICT 8

ENTIRE COUNTIES

Albany, Allegany, Bronx, Broome, Cattaraugus, Cayuga, Chautauqua, Chemung, Chenango, Clinton, Columbia, Cortland, Delaware, Dutchess, Erie, Essex, Franklin, Fulton, Genesee, Greene, Hamilton, Herkimer, Jefferson, Kings, Lewis, Livingston, Madison, Monroe, Montgomery, Nassau, New York, Niagara, Oneida, Onondaga, Ontario, Orange, Orleans, Oswego, Otsego, Putnam, Queens, Rensselaer, Richmond, Rockland, Saratoga, Schenectady, Schoharie, Schuyler, Seneca, St. Lawrence, Steuben, Suffolk, Sullivan, Tioga, Tompkins, Ulster, Warren, Washington, Wayne, Westchester, Wyoming, Yates

WAGES

	07/01/2019
Metal Polisher	\$ 30.58
Metal Polisher*	31.53
Metal Polisher**	34.08

*Note: Applies on New Construction & complete renovation

** Note: Applies when working on scaffolds over 34 feet.

SUPPLEMENTAL BENEFITS

Per Hour: 07/01/2019

Journeyworker:

All classification \$ 7.72

OVERTIME PAY

See (B, E, P, T) on OVERTIME PAGE

HOLIDAY

Paid: See (5, 6, 11, 15, 16, 25, 26) on HOLIDAY PAGE

Overtime: See (5, 6, 9, 11, 15, 16, 25, 26) on HOLIDAY PAGE

REGISTERED APPRENTICES

Wages per hour:

One (1) year term at the following wage rates:

07/01/2019

1st year	\$ 15.00
2nd year	15.00
3rd year	15.75

1st year*	\$ 17.39
2nd year*	17.44
3rd year*	18.29

1st year**	\$ 19.50
2nd year**	19.50
3rd year**	20.25

*Note: Applies on New Construction & complete renovation

** Note: Applies when working on scaffolds over 34 feet.

Supplemental benefits:

Per hour:

1st year	\$ 5.52
2nd year	5.52
3rd year	5.52

8-8A/28A-MP

Plumber**11/01/2019**

JOB DESCRIPTION Plumber

DISTRICT 3

ENTIRE COUNTIES

Erie, Niagara, Wyoming

PARTIAL COUNTIES

Allegheny: Only the Townships of Allen, Angelica, Belfast, Caneadea, Centerville, Granger, Hume, New Hudson and Rushford
Cattaraugus: Only the Townships of Ashford, Dayton, East Otto, Ellicottville, Farmersville, Franklinville, Freedom, Leon, Lyndon, Machias, Mansfield, New Albion, Otto, Perrysburg, Persia and Yorkshire.

Chautauqua: Only the Townships of Arkwright, Charlotte, Cherry Creek, Dunkirk, Hanover, Pomfret, Portland, Ripley, Sheridan, Stockton, Villenova, Westfield, City of Dunkirk and Village of Fredonia.

Genesee: Only the Townships of Alabama, Alexander, Batavia, Darien, Elba, Oakfield, Pembroke and the City of Batavia.

Orleans: Only the Townships of Ridgeway, Shelby and Yates.

WAGES

Per hour: 07/01/2019

Plumber	\$ 35.60
Steamfitter	\$ 35.60

Note - Add 10% (ten-percent) to wage when HAZMAT training is required or when OSHA compliant respirator protection is required.

SUPPLEMENTAL BENEFITS

Per hour:

\$ 25.86

Note - \$3.40 of this amount must be paid at the same premium as the wage.

OVERTIME PAY

See (*B, **E, Q) on OVERTIME PAGE

* Double time after 11 hours per day on Weekdays.

** Double time after 10 hours per day on Saturday.

HOLIDAY

Paid: See (1) on HOLIDAY PAGE

Overtime: See (5, 6, 16) on HOLIDAY PAGE

REGISTERED APPRENTICES

Wages per hour:

One year terms at the following percentage of Journeyman's wage:

1st	2nd	3rd	4th	5th
45%	55%	65%	75%	90%

Note - Add 10% (ten-percent) to wage when HAZMAT training is required or when OSHA compliant respirator protection is required.

Supplemental benefits per hour:

\$ 21.30

Note - \$3.40 of this amount must be paid at the same premium as the wage.

3-22-Buffalo, Niagara

Plumber**11/01/2019**

JOB DESCRIPTION Plumber

DISTRICT 3

ENTIRE COUNTIES

PARTIAL COUNTIES

Allegany: Only the Townships of Alma, Amity, Bolivar, Clarksville, Cuba, Friendship, Genesee, Wirt and that portion of Scio which lies west of Rt. 19.

Cattaraugus: Only the Townships of Allegany, Carrollton, Conewango, Cold Spring, Great Valley, Hinsdale, Humphrey, Ischua, Little Valley, Napoli, Olean, Portville, Randolph, Red House, Salamanca, South Valley, the City of Olean, the City of Salamanca, and the Allegany Indian Reservation.

Chautauqua: Only the Townships of Busti, Carroll, Chautauqua, Clymer, Ellery, Ellicott, Ellington, French Creek, Gerry, Harmony, Kiantone, Mina, North Harmony, Poland, Sherman, and the City of Jamestown.

WAGES

Per hour: 07/01/2019

Plumber \$ 34.03
Steamfitter \$ 34.03

Note - Add 10% (ten-percent) to wage when HAZMAT training is required or when OSHA compliant respirator protection is required.

SUPPLEMENTAL BENEFITS

Per hour: \$ 25.86

Note - \$3.40 of this amount must be paid at the same premium as the wage.

OVERTIME PAY

See (*B, **E, Q) on OVERTIME PAGE

* Double time after 11 hours per day on Weekdays.

** Double time after 10 hours per day on Saturday.

HOLIDAY

Paid: See (1) on HOLIDAY PAGE

Overtime: See (5, 6, 16) on HOLIDAY PAGE

REGISTERED APPRENTICES

Wages per hour:

One year terms at the following percentage of Journeyman's wage:

1st	2nd	3rd	4th	5th
45%	55%	65%	75%	90%

Note - Add 10% (ten-percent) to wage when HAZMAT training is required or when OSHA compliant respirator protection is required.

Supplemental benefits per hour:

\$ 21.30

Note - \$3.40 of this amount must be paid at the same premium as the wage.

3-22-Southern

Roofer **11/01/2019**

JOB DESCRIPTION Roofer

DISTRICT 3

ENTIRE COUNTIES

Allegany, Cattaraugus, Chautauqua

WAGES

Per hour: 07/01/2019

Roofer \$ 31.00
Waterproofing 31.00

Asbestos Removal with respirator or protective suit add \$1.00 per hour.

SUPPLEMENTAL BENEFITS

Per hour: \$ 13.95

OVERTIME PAY

See (B, E, E2, Q) on OVERTIME PAGE

HOLIDAY

Paid: See (1) on HOLIDAY PAGE

Overtime: See (5, 6) on HOLIDAY PAGE

REGISTERED APPRENTICES

Wages per hour:

750 hour terms at the following percentage of Journeyman's wage:

1st	2nd	3rd	4th	5th	6th
50%	50%	60%	70%	80%	90%

Supplemental benefits per hour:

1st & 2nd terms	\$ 0.58
All other terms	13.95

3-210

Sheetmetal Worker **11/01/2019**

JOB DESCRIPTION Sheetmetal Worker **DISTRICT 3**

ENTIRE COUNTIES
 Cattaraugus, Chautauqua

WAGES

Per hour:	07/01/2019	07/01/2020	07/01/2021
Sheet Metal Worker	\$ 27.75	\$0.75	\$0.75

Additional \$1.00 per hour for work performed at a height of fifty (50) feet or more on boatswains chair, swing (of any type), picks and plank.

The following premiums apply when shift work is mandated in the job specification or by the contracting agency:

- 15% when the majority of the hours are worked between the hours of 3:30PM - 1:00AM
- 20% when the majority of the hours are worked between the hours of 11:00PM - 9:00AM

SUPPLEMENTAL BENEFITS

Per hour:	\$ 23.53
-----------	----------

OVERTIME PAY

See (B, E, Q) on OVERTIME PAGE

HOLIDAY

Paid: See (1) on HOLIDAY PAGE
 Overtime: See (5, 6) on HOLIDAY PAGE

REGISTERED APPRENTICES

Wages per:

1000 hour year terms:

1st	2nd	3rd	4th	5th	6th	7th	8th
\$ 13.88	\$ 14.99	\$ 16.10	\$ 17.21	\$ 18.32	\$ 19.43	\$ 20.54	\$ 21.65

Supplemental Benefits

07/01/2019

1st term	\$ 13.29
2nd term	13.84
3rd term	16.04
4th term	16.70
5th term	17.36
6th term	18.02
7th term	18.68
8th term	19.33

3-112-Jamestown

Sprinkler Fitter **11/01/2019**

JOB DESCRIPTION Sprinkler Fitter **DISTRICT 1**

ENTIRE COUNTIES

Allegany, Broome, Cattaraugus, Cayuga, Chautauqua, Chemung, Chenango, Clinton, Columbia, Cortland, Delaware, Erie, Essex, Franklin, Fulton, Genesee, Greene, Hamilton, Herkimer, Jefferson, Lewis, Livingston, Madison, Monroe, Montgomery, Niagara, Oneida, Onondaga, Ontario, Orleans, Oswego, Otsego, Schoharie, Schuyler, Seneca, St. Lawrence, Steuben, Tioga, Tompkins, Washington, Wayne, Wyoming, Yates

WAGES

Per hour	07/01/2019
Sprinkler Fitter	\$ 34.91

SUPPLEMENTAL BENEFITS

Per hour

Journeyman \$ 24.93

OVERTIME PAY

See (B, E, Q) on OVERTIME PAGE

HOLIDAY

Paid: See (1) on HOLIDAY PAGE

Overtime: See (5, 6) on HOLIDAY PAGE

Note: When a holiday falls on Sunday, the following Monday shall be considered a holiday and all work performed on either day shall be at the double time rate. When a holiday falls on Saturday, the preceding Friday shall be considered a holiday and all work performed on either day shall be at the double time rate.

REGISTERED APPRENTICES

Wages per hour

For Apprentices HIRED ON OR AFTER 04/01/2010:

One Half Year terms at the following percentage of journeyman's wage.

1st	2nd	3rd	4th	5th	6th	7th	8th	9th	10th
45%	50%	55%	60%	65%	70%	75%	80%	85%	90%

Supplemental Benefits per hour worked

1st	2nd	3rd	4th	5th	6th	7th	8th	9th	10th
\$ 9.18	\$ 9.22	\$ 17.89	\$ 17.93	\$ 18.48	\$ 18.52	\$ 18.57	\$ 18.61	\$ 18.66	\$ 18.70

For Apprentices HIRED ON OR AFTER 04/01/2013:

One Half Year terms at the following percentage of journeyman's wage.

1st	2nd	3rd	4th	5th	6th	7th	8th	9th	10th
45%	50%	55%	60%	65%	70%	75%	80%	85%	90%

Supplemental Benefits per hour worked

1st	2nd	3rd	4th	5th	6th	7th	8th	9th	10th
\$ 8.27	\$ 8.27	\$ 18.04	\$ 18.04	\$ 18.29	\$ 18.29	\$ 18.29	\$ 18.29	\$ 18.29	\$ 18.29

1-669

Teamster - Building / Heavy&Highway **11/01/2019**

JOB DESCRIPTION Teamster - Building / Heavy&Highway

DISTRICT 3

ENTIRE COUNTIES

Cattaraugus, Chautauqua

PARTIAL COUNTIES

Allegany: Entire county except the Townships of Alfred, Almond, Burns and West Almond.

WAGES

GROUP 1: Warehousemen, Yardmen, Truck Helpers, Panel Trucks, Flatboy Material Trucks (straight jobs), Single Axle Dump Trucks, Dumpsters, Material Checkers and Receivers, Greasers, Truck Tiremen, Mechanics Helpers and Parts Chasers, Tandems and Batch Trucks, Mechanics, Dispatcher, Semi-Trailers, Low-boy Trucks, Asphalt Distributor Trucks, and Agitator, Mixer Trucks and Dumpcrete type vehicles, Truck Mechanic, Fuel Trucks.

GROUP 2: Specialized Earth Moving Equipment, Euclid type, or similar off-highway where not self-loading and self-contained concrete mobile unit, Off-highway Tandem Back-Dump, Twin Engine Equipment and Double-Hitched Equipment where not self-loading, Water Tanks, Sprinkler Trucks and Winch Trucks.

Per hour: 07/01/2019

GROUP 1 \$ 38.31

GROUP 2 38.31

Add \$ 2.00 when required to use personal protection when performing hazardous waste removal work.

Add \$ 2.00 while operating articulating truck.

SUPPLEMENTAL BENEFITS

Per hour: \$ 14.78

OVERTIME PAY
See (B, E, Q) on OVERTIME PAGE

HOLIDAY
Paid: See (5, 20) on HOLIDAY PAGE
Overtime: See (5, 6) on HOLIDAY PAGE

3-264

Welder **11/01/2019**

JOB DESCRIPTION Welder **DISTRICT 1**

ENTIRE COUNTIES
Albany, Allegany, Bronx, Broome, Cattaraugus, Cayuga, Chautauqua, Chemung, Chenango, Clinton, Columbia, Cortland, Delaware, Dutchess, Erie, Essex, Franklin, Fulton, Genesee, Greene, Hamilton, Herkimer, Jefferson, Kings, Lewis, Livingston, Madison, Monroe, Montgomery, Nassau, New York, Niagara, Oneida, Onondaga, Ontario, Orange, Orleans, Oswego, Otsego, Putnam, Queens, Rensselaer, Richmond, Rockland, Saratoga, Schenectady, Schoharie, Schuylar, Seneca, St. Lawrence, Steuben, Suffolk, Sullivan, Tioga, Tompkins, Ulster, Warren, Washington, Wayne, Westchester, Wyoming, Yates

WAGES
Per hour 07/01/2019

Welder: To be paid the same rate of the mechanic performing the work.*

*EXCEPTION: If a specific welder certification is required, then the 'Certified Welder' rate in that trade tag will be paid.

OVERTIME PAY

HOLIDAY

1-As Per Trade

Overtime Codes

Following is an explanation of the code(s) listed in the OVERTIME section of each classification contained in the attached schedule. Additional requirements may also be listed in the HOLIDAY section.

NOTE: Supplemental Benefits are 'Per hour worked' (for each hour worked) unless otherwise noted

- (AA) Time and one half of the hourly rate after 7 and one half hours per day
- (A) Time and one half of the hourly rate after 7 hours per day
- (B) Time and one half of the hourly rate after 8 hours per day
- (B1) Time and one half of the hourly rate for the 9th & 10th hours week days and the 1st 8 hours on Saturday.
Double the hourly rate for all additional hours
- (B2) Time and one half of the hourly rate after 40 hours per week
- (C) Double the hourly rate after 7 hours per day
- (C1) Double the hourly rate after 7 and one half hours per day
- (D) Double the hourly rate after 8 hours per day
- (D1) Double the hourly rate after 9 hours per day
- (E) Time and one half of the hourly rate on Saturday
- (E1) Time and one half 1st 4 hours on Saturday; Double the hourly rate all additional Saturday hours
- (E2) Saturday may be used as a make-up day at straight time when a day is lost during that week due to inclement weather
- (E3) Between November 1st and March 3rd Saturday may be used as a make-up day at straight time when a day is lost during that week due to inclement weather, provided a given employee has worked between 16 and 32 hours that week
- (E4) Saturday and Sunday may be used as a make-up day at straight time when a day is lost during that week due to inclement weather
- (E5) Double time after 8 hours on Saturdays
- (F) Time and one half of the hourly rate on Saturday and Sunday
- (G) Time and one half of the hourly rate on Saturday and Holidays
- (H) Time and one half of the hourly rate on Saturday, Sunday, and Holidays
- (I) Time and one half of the hourly rate on Sunday
- (J) Time and one half of the hourly rate on Sunday and Holidays
- (K) Time and one half of the hourly rate on Holidays
- (L) Double the hourly rate on Saturday
- (M) Double the hourly rate on Saturday and Sunday
- (N) Double the hourly rate on Saturday and Holidays
- (O) Double the hourly rate on Saturday, Sunday, and Holidays
- (P) Double the hourly rate on Sunday
- (Q) Double the hourly rate on Sunday and Holidays
- (R) Double the hourly rate on Holidays
- (S) Two and one half times the hourly rate for Holidays

- (S1) Two and one half times the hourly rate the first 8 hours on Sunday or Holidays One and one half times the hourly rate all additional hours.
- (T) Triple the hourly rate for Holidays
- (U) Four times the hourly rate for Holidays
- (V) Including benefits at SAME PREMIUM as shown for overtime
- (W) Time and one half for benefits on all overtime hours.
- (X) Benefits payable on Paid Holiday at straight time. If worked, additional benefit amount will be required for worked hours. (Refer to other codes listed.)

Holiday Codes

PAID Holidays:

Paid Holidays are days for which an eligible employee receives a regular day's pay, but is not required to perform work. If an employee works on a day listed as a paid holiday, this remuneration is in addition to payment of the required prevailing rate for the work actually performed.

OVERTIME Holiday Pay:

Overtime holiday pay is the premium pay that is required for work performed on specified holidays. It is only required where the employee actually performs work on such holidays. The applicable holidays are listed under HOLIDAYS: OVERTIME. The required rate of pay for these covered holidays can be found in the OVERTIME PAY section listings for each classification.

Following is an explanation of the code(s) listed in the HOLIDAY section of each classification contained in the attached schedule. The Holidays as listed below are to be paid at the wage rates at which the employee is normally classified.

- (1) None
- (2) Labor Day
- (3) Memorial Day and Labor Day
- (4) Memorial Day and July 4th
- (5) Memorial Day, July 4th, and Labor Day
- (6) New Year's, Thanksgiving, and Christmas
- (7) Lincoln's Birthday, Washington's Birthday, and Veterans Day
- (8) Good Friday
- (9) Lincoln's Birthday
- (10) Washington's Birthday
- (11) Columbus Day
- (12) Election Day
- (13) Presidential Election Day
- (14) 1/2 Day on Presidential Election Day
- (15) Veterans Day
- (16) Day after Thanksgiving
- (17) July 4th
- (18) 1/2 Day before Christmas
- (19) 1/2 Day before New Years
- (20) Thanksgiving
- (21) New Year's Day
- (22) Christmas
- (23) Day before Christmas
- (24) Day before New Year's
- (25) Presidents' Day
- (26) Martin Luther King, Jr. Day
- (27) Memorial Day
- (28) Easter Sunday



**New York State Department of Labor - Bureau of Public Work
State Office Building Campus
Building 12 - Room 130
Albany, New York 12240**

REQUEST FOR WAGE AND SUPPLEMENT INFORMATION

As Required by Articles 8 and 9 of the NYS Labor Law

Fax (518) 485-1870 or mail this form for new schedules or for determination for additional occupations.

This Form Must Be Typed

Submitted By:

(Check Only One)

Contracting Agency

Architect or Engineering Firm

Public Work District Office

Date:

A. Public Work Contract to be let by: (Enter Data Pertaining to Contracting/Public Agency)

1. Name and complete address (Check if new or change)

Telephone: ()

Fax: ()

E-Mail:

2. NY State Units (see Item 5)

01 DOT

02 OGS

03 Dormitory Authority

04 State University
Construction Fund

05 Mental Hygiene
Facilities Corp.

06 OTHER N.Y. STATE UNIT

07 City

08 Local School District

09 Special Local District, i.e.,
Fire, Sewer, Water District

10 Village

11 Town

12 County

13 Other Non-N.Y. State
(Describe)

3. SEND REPLY TO check if new or change)
Name and complete address:

Telephone:()

Fax: ()

E-Mail:

4. SERVICE REQUIRED. Check appropriate box and provide project information.

New Schedule of Wages and Supplements.

APPROXIMATE BID DATE :

Additional Occupation and/or Redetermination

PRC NUMBER ISSUED PREVIOUSLY FOR
THIS PROJECT :

OFFICE USE ONLY

B. PROJECT PARTICULARS

5. Project Title _____

Description of Work _____

Contract Identification Number _____

Note: For NYS units, the OSC Contract No. _____

6. Location of Project:
Location on Site _____

Route No/Street Address _____

Village or City _____

Town _____

County _____

7. Nature of Project - Check One:

- 1. New Building
- 2. Addition to Existing Structure
- 3. Heavy and Highway Construction (New and Repair)
- 4. New Sewer or Waterline
- 5. Other New Construction (Explain)
- 6. Other Reconstruction, Maintenance, Repair or Alteration
- 7. Demolition
- 8. Building Service Contract

8. OCCUPATION FOR PROJECT :

- Construction (Building, Heavy Highway/Sewer/Water)
- Tunnel
- Residential
- Landscape Maintenance
- Elevator maintenance
- Exterminators, Fumigators
- Fire Safety Director, NYC Only
- Guards, Watchmen
- Janitors, Porters, Cleaners, Elevator Operators
- Moving furniture and equipment
- Trash and refuse removal
- Window cleaners
- Other (Describe)

9. Has this project been reviewed for compliance with the Wicks Law involving separate bidding? YES NO

10. Name and Title of Requester

Signature



NEW YORK STATE DEPARTMENT OF LABOR
Bureau of Public Work - Debarment List

**LIST OF EMPLOYERS INELIGIBLE TO BID ON OR BE
AWARDED ANY PUBLIC WORK CONTRACT**

Under Article 8 and Article 9 of the NYS Labor Law, a contractor, sub-contractor and/or its successor shall be debarred and ineligible to submit a bid on or be awarded any public work or public building service contract/sub-contract with the state, any municipal corporation or public body for a period of five (5) years from the date of debarment when:

- Two (2) final determinations have been rendered within any consecutive six-year (6) period determining that such contractor, sub-contractor and/or its successor has WILLFULLY failed to pay the prevailing wage and/or supplements;
- One (1) final determination involves falsification of payroll records or the kickback of wages and/or supplements.

The agency issuing the determination and providing the information, is denoted under the heading 'Fiscal Officer'. DOL = New York State Department of Labor; NYC = New York City Comptroller's Office; AG = New York State Attorney General's Office; DA = County District Attorney's Office.

Debarment Database: To search for contractors, sub-contractors and/or their successors debarred from bidding or being awarded any public work contract or subcontract under NYS Labor Law Articles 8 and 9, or under NYS Workers' Compensation Law Section 141-b, access the database at this link: <https://applications.labor.ny.gov/EDList/searchPage.do>

For inquiries where WCB is listed as the "Agency", please call 1-866-546-9322

NYS DOL Bureau of Public Work Debarment List 08/29/2019

Article 8

AGENCY	Fiscal Officer	FEIN	EMPLOYER NAME	EMPLOYER DBA NAME	ADDRESS	DEBARMENT START DATE	DEBARMENT END DATE
DOL	DOL	****0996	A-1 CONSTRUCTION & RENOVATION INC		1973 81ST ST - SUITE A-5 BROOKLYN NY 11214	01/08/2015	01/08/2020
DOL	NYC		ABDUL KARIM		C/O NORTH AMERICAN IRON W 1560 DECATUR STREETRIDGWOOD NY 11385	05/15/2015	05/15/2020
DOL	DOL	****4539	ACCOMPLISHED WALL SYSTEMS INC		112 OSCAWANNA HEIGHTS RD PUTNAM VALLEY NY 10542	03/13/2015	03/12/2020
DOL	DOL	****3344	ACT INC		6409 LAND O LAKES BLVD LAND O LAKES FL 34638	11/10/2015	11/10/2020
DOL	DOL	****4018	ADIRONDACK BUILDING RESTORATION INC.		4156 WILSON ROAD EAST TABERG NY 13471	03/26/2019	03/26/2024
DOL	DOL	****1687	ADVANCED SAFETY SPRINKLER INC		261 MILL ROAD P.O BOX 296EAST AURORA NY 14052	07/29/2015	07/29/2020
DOL	DOL	****1687	ADVANCED SAFETY SPRINKLER INC		261 MILL ROAD P.O BOX 296EAST AURORA NY 14052	05/29/2019	05/29/2024
DOL	NYC	****6775	ADVENTURE MASONRY CORP.		1535 RICHMOND AVENUE STATEN ISLAND NY 10314	12/13/2017	12/13/2022
DOL	DOL		AJ TORCHIA		10153 ROBERTS RD SAUQUOIT NY 13456	08/09/2016	08/09/2021
DOL	DOL	****3344	ALL CATASTROPHE CONSTRUCTION TEAM INC	ACT INC	6409 LAND O LAKES BLVD LAND O LAKES FL 34638	11/10/2015	11/10/2020
DOL	DOL	****8740	ALLSTATE ENVIRONMENTAL CORP		C/O JOSE MONTAS 27 BUTLER PLACEYONKERS NY 10710	03/18/2011	03/19/2020
DOL	DOL		AMADEO J TORCHIA	TORCHIA'S HOME IMPROVEMENT	10153 ROBERTS RD SAUQUOIT NY 13456	08/09/2016	08/09/2021
DOL	DOL		ANGELO F COKER			12/04/2018	12/04/2023
DOL	NYC		ANISUL ISLAM		C/O RELIANCE GENERAL CONS 644 OCEAN PARKWAYBROOKLYN NY 11230	09/02/2015	09/02/2020
DOL	DOL		ANITA SALERNO		158 SOLAR ST SYRACUSE NY 13204	01/07/2019	01/07/2024
DOL	DA		ANTHONY CARDINALE		58-48 59TH STREET MASPETH NY 11378	05/16/2012	05/08/2020
DOL	DOL		ANTHONY J MINGARELLI JR		C/O T & T CONCRETE INC 2560 HAMBURG TURNPIKELACKAWANNA NY 14218	07/08/2015	07/08/2020
DOL	DOL		ANTHONY PERGOLA		3 WEST MAIN ST/SUITE 208 ELMSFORD NY 10323	01/23/2017	01/23/2022
DOL	DOL		ANTONIO ESTIVEZ		442 ARMONK RD MOUNT KISCO NY 10549	06/12/2018	06/12/2023
DOL	DOL	****3020	APCO CONTRACTING CORP		24 SOUTH MARYLAND AVENUE PORT WASHINGTON NY 11050	09/24/2012	09/02/2020
DOL	NYC	****9232	ARKAY CONSTRUCTION INC		102-104 GREYLOCK AVENUE BELLEVILLE NJ 07109	07/15/2015	07/15/2020
DOL	NYC	****4779	ASTORIA GENERAL CONTRACTING CORP		35-34 31ST STREET LONG ISLAND CITY NY 11106	09/02/2015	09/02/2020
DOL	NYC	****7217	ASTRO COMMUNICATIONS OF NY CORP		79 ALEXANDER AVE- STE 36A BRONX NY 10454	10/30/2015	10/30/2020
DOL	NYC	****6046	ATLANTIC SUN CONSTRUCTION CORP		58-46 59TH AVENUE MASPETH NY 11378	05/08/2015	05/08/2020
DOL	NYC	****6683	ATLAS RESTORATION CORP.		35-12 19TH AVENUE ASTORIA NY 11105	08/02/2017	08/02/2022
DOL	NYC		AUDLEY O'BRIEN		1273 NORTH AVENUE/#1 CP NEW ROCHELLE NY 10804	04/07/2015	04/07/2020
DOL	NYC	****2591	AVI 212 INC.		260 CROPSEY AVENUE APT 11GBROOKLYN NY 11214	10/30/2018	10/30/2023
DOL	DOL		AVIS R HILL		3510 HICKORY WALK LANE ELLENWOOD GA 32094	01/22/2015	01/22/2020
DOL	AG		AVTAR SINGH		116-24 127TH STREET SOUTH OZONE PARK NY 11420	12/22/2015	12/22/2020
DOL	AG		BALDEV SINGH		116-24 127TH STREET SOUTH OZONE PARK NY 11420	12/22/2015	12/22/2020

NYS DOL Bureau of Public Work Debarment List 08/29/2019

Article 8

DOL	NYC		BALWINDER SINGH		421 HUDSON ST SUITE C5NEW YORK NY 10014	02/20/2019	02/20/2024
DOL	DOL		BARBARA CASSIDY		7 BLENIS PLACE VALHALLA NY 10595	04/02/2015	04/02/2020
DOL	DOL		BARRY KINNEY		6409 LAND O LAKES BLVD LAND O LAKES FL 34638	11/10/2015	11/10/2020
DOL	NYC	****3915	BEACON RESTORATION INC		SUITE B-8 782 PELHAM PARKWAY SOUTHBRONX NY 10462	04/21/2016	04/21/2021
DOL	NYC	****8416	BEAM CONSTRUCTION, INC.		50 MAIN ST WHITE PLAINS NY 10606	01/04/2019	01/04/2024
DOL	DOL		BIAGIO CANTISANI			06/12/2018	06/12/2023
DOL	DOL	****4512	BOB BRUNO EXCAVATING, INC		5 MORNINGSIDE DR AUBURN NY 13021	05/28/2019	05/28/2024
DOL	DOL		BOGDAN MARKOVSKI		370 W. PLEASANTVIEW AVE SUITE 2.329HACKENSACK NJ 07601	02/11/2019	02/11/2024
DOL	DOL	****8551	BRANDY'S MASONRY		216 WESTBROOK STREET P O BOX 304SAYRE PA 18840	08/09/2016	08/09/2021
DOL	NYC	****6555	BROOKLYN WELDING CORP		1273 NORTH AVENUE/ #1 CP NEW ROCHELLE NY 10804	04/07/2015	04/07/2020
DOL	DOL	****1449	BRRESTORATION NY INC		140 ARCADIA AVENUE OSWEGO NY 13126	09/12/2016	09/12/2021
DOL	DOL		BRUCE MORSEY		C/O KENT HOLLOW SIDING LL 29A BRIDGE STREETNEW MILFORD CT 06776	01/15/2016	01/15/2021
DOL	DOL		BRUCE P. NASH JR.		5841 BUTTERNUT ROAD EAST SYRACUSE NY 13057	09/12/2018	09/12/2023
DOL	DOL	****8809	C.B.E. CONTRACTING CORPORATION		310 MCGUINNESS BLVD GREENPOINT NY 11222	03/07/2017	03/07/2022
DOL	DOL	****9383	C.C. PAVING AND EXCAVATING, INC.		2610 SOUTH SALINA ST SUITE 12SYRACUSE NY 13205	12/04/2018	12/04/2023
DOL	DOL		CANTISANI & ASSOCIATES LTD		442 ARMONK RD MOUNT KISCO NY 10549	06/12/2018	06/12/2023
DOL	DOL		CANTISANI HOLDING LLC			06/12/2018	06/12/2023
DOL	DOL		CARIBBEAN POOLS		C/O DOUGLAS L MALARKEY 64 VICTORIA DRIVEBINGHAMTON NY 13904	02/04/2016	02/04/2021
DOL	DOL	****3812	CARMODY "2" INC			06/12/2018	06/12/2023
DOL	DOL	****1143	CARMODY BUILDING CORP	CARMODY CONTRACTIN G AND CARMODY CONTRACTIN G CORP.	442 ARMONK RD MOUNT KISCO NY 10549	06/12/2018	06/12/2023
DOL	DOL		CARMODY CONCRETE CORPORATION			06/12/2018	06/12/2023
DOL	DOL		CARMODY ENTERPRISES, LTD.		442 ARMONK RD MOUNT KISCO NY 10549	06/12/2018	06/12/2023
DOL	DOL		CARMODY INC		442 ARMONK RD MOUNT KISCO NY 10549	06/12/2018	06/12/2023
DOL	DOL	****3812	CARMODY INDUSTRIES INC			06/12/2018	06/12/2023
DOL	DOL		CARMODY MAINTENANCE CORPORATION		442 ARMONK RD MOUNT KISCO NY 10549	06/12/2018	06/12/2023
DOL	DOL		CARMODY MASONRY CORP		442 ARMONK RD MOUNT KISCO NY 10549	06/12/2018	06/12/2023
DOL	NYC	****9172	CASSIDY EXCAVATING INC		14 RAILROAD AVENUE VALHALLA NY 10595	05/15/2014	04/02/2020
DOL	DOL	****8809	CBE CONTRACTING CORP		142 EAST MARKET STREET LONG BEACH NY 11561	03/07/2017	03/07/2022
DOL	AG		CESAR J. AGUDELO		81-06 34TH AVENUE APT. 6EJACKSON HEIGHTS NY 11372	02/07/2018	02/07/2023
DOL	DOL	****7655	CHAMPION CONSTRUCTION SERVICES CORP		2131 SCHENECTADY AVENUE BROOKLYN NY 11234	11/18/2015	11/18/2020
DOL	NYC		CHARLES CASSIDY JR		14 RAILROAD AVENUE VALHALLA NY 10595	05/15/2014	04/02/2020
DOL	DOL		CHARLES ZIMMER JR		216 WESTBROOK STREET P O BOX 304SAYRE PA 18840	08/09/2016	08/09/2021
DOL	DOL		CHRISTINE J HEARNE		C/O CJ-HEARNE CONSTRUCTIO 131 PONCE DE LEON AVE NEATLANTA GA 30308	12/01/2015	12/01/2020

NYS DOL Bureau of Public Work Debarment List 08/29/2019

Article 8

DOL	DOL		CHRISTOPHER J MAINI		19 CAITLIN AVE JAMESTOWN NY 14701	09/17/2018	09/17/2023
DOL	DOL		CHRISTOPHER PAPASTEFANO A/K/A CHRIS PAPASTEFANO		1445 COMMERCE AVE BRONX NY 10461	05/30/2019	05/30/2024
DOL	DOL	****0671	CJ-HEARNE CONSTRUCTION CO		SUITE 204 131 PONCE DE LEON AVENUE ATLANTA GA 30308	12/01/2015	12/01/2020
DOL	DOL	****1927	CONSTRUCTION PARTS WAREHOUSE, INC.	CPW	5841 BUTTERNUT ROAD EAST SYRACUSE NY 13057	09/12/2018	09/12/2023
DOL	NYC	****2164	CREATIVE TRUCKING INC		58-83 54TH STREET MASPETH NY 11378	02/26/2016	02/26/2021
DOL	DOL	****2524	CSI ELECTRICAL & MECHANICAL INC		42-32 235TH ST DOUGLSTON NY 11363	01/14/2019	01/14/2024
DOL	DOL	****7761	D L MALARKEY CONSTRUCTION		64 VICTORIA DRIVE BINGHAMTON NY 13904	02/04/2016	02/04/2021
DOL	DOL	****7888	D L MALARKEY CONSTRUCTION INC		64 VICTORIA DRIVE BINGHAMTON NY 13904	02/04/2016	02/04/2021
DOL	DOL	****5629	DAKA PLUMBING AND HEATING LLC		2561 ROUTE 55 POUGHQUAG NY 12570	02/19/2016	02/19/2021
DOL	DOL		DANICA IVANOSKI		61 WILLET ST. PASSAIC NJ 07503	10/26/2016	10/26/2021
DOL	DOL		DARIAN L COKER		2610 SOUTH SALINA ST SUITE 2C SYRACUSE NY 13205	12/04/2018	12/04/2023
DOL	DOL		DARYL T RIEKS		C/O RIEKS CONTRACTING LLC 4804 GAHWILER ROAD AUBURN NY 13021	05/01/2015	05/01/2020
DOL	NYC	****7707	DASSLE CONTRACTING INC		213-37 39TH AVE/SUITE 120 BAYSIDE NY 11360	05/08/2015	05/08/2020
DOL	DOL		DAVID MARTINEZ		C/O EMPIRE TILE INC 6 TREMONT COURT HUNTINGTON STATION NY 11746	03/08/2016	03/08/2021
DOL	DOL		DEBBIE STURDEVANT		29 MAPLEWOOD DRIVE BINGHAMTON NY 13901	02/21/2017	02/21/2022
DOL	AG		DEBRA MARTINEZ		31 BAY ST BROOKLYN NY 11231	03/28/2018	03/28/2023
DOL	DOL		DEDA GAZIVODAN		C/O DAKA PLUMBING AND H 2561 ROUTE 55 POUGHQUAG NY 12570	02/19/2016	02/19/2021
DOL	DOL		DELPHI PAINTING & DECORATING CO INC		1445 COMMERCE AVE BRONX NY 10461	05/30/2019	05/30/2024
DOL	DOL		DENNIS SCHWANDTNER		C/O YES SERVICE AND REPAIR 145 LODGE AVE HUNTINGTON STATION NY 11476	08/09/2016	08/09/2021
DOL	DOL		DF CONTRACTORS OF ROCHESTER, INC.		1835 DAANSEN RD. PALMYRA NY 14522	05/16/2017	05/16/2022
DOL	DOL		DF CONTRACTORS, INC.		1835 DAANSEN RD. PALMYRA NY 14522	05/16/2017	05/16/2022
DOL	NYC		DIMITRIOS KOUTSOUKOS		C/O ASTORIA GENERAL CONTR 35-34 31ST STREET LONG ISLAND CITY NY 11106	09/02/2015	09/02/2020
DOL	NYC		DIMITRIOS TSOUMAS		35-12 19TH AVENUE ASTORIA NY 11105	08/02/2017	08/02/2022
DOL	DOL	****3242	DONALD R. FORSAY	DF LAWN SERVICE	1835 DAANSEN RD. PALMYRA NY 14522	05/16/2017	05/16/2022
DOL	DOL		DONALD R. FORSAY		1835 DAANSEN RD. PALMYRA NY 14522	05/16/2017	05/16/2022
DOL	DOL		DORIS SKODA		C/O APCO CONTRACTING CORP 24 SOUTH MARYLAND AVENUE PORT WASHINGTON NY 11050	09/24/2012	09/02/2020
DOL	NYC	****7404	DOSANJH CONSTRUCTION CORP		9439 212TH STREET QUEENS VILLAGE NY 11428	02/25/2016	02/25/2021
DOL	DOL		DOUGLAS L MALARKEY	MALARKEY CONSTRUCTION	64 VICTORIA DRIVE BINGHAMTON NY 13904	02/04/2016	02/04/2021
DOL	DOL		E C WEBB		6409 LAND O LAKES BLVD LAND O LAKES FL 34638	11/10/2015	11/10/2020
DOL	DOL		EARL L WILSON	WILSON BROTHER DRYWALL CONTRACTORS	36 ABERSOLD STREET ROCHESTER NY 14621	08/31/2015	08/31/2020
DOL	DOL		EAST COAST PAVING		2238 BAKER RD GILLET PA 16923	03/12/2018	03/12/2023
DOL	DOL	****0780	EMES HEATING & PLUMBING CONTR		5 EMES LANE MONSEY NY 10952	01/20/2002	01/20/3002

NYS DOL Bureau of Public Work Debarment List 08/29/2019

Article 8

DOL	DOL	****3270	EMPIRE TILE INC		6 TREMONT COURT HUNTINGTON STATION NY 11746	03/08/2016	03/08/2021
DOL	DOL	****7403	F & B PAINTING CONTRACTING INC		2 PARKVIEW AVENUE HARRISON NY 10604	09/26/2016	09/26/2021
DOL	DOL		FAIGY LOWINGER		11 MOUNTAIN RD 28 VAN BUREN DRMONROE NY 10950	03/20/2019	03/20/2024
DOL	DOL		FAY MATTHEW		C/O CHAMPION CONSTRUCTION 2131 SCHENECTADY AVENUEBROOKLYN NY 11234	11/18/2015	11/18/2020
DOL	DOL		FAZIA GINA ALI-MOHAMMED	C/O CHAMPION CONSTRUCTI ON	2131 SCHENECTADY AVENUE BROOKLYN NY 11234	11/18/2015	11/18/2020
DOL	DOL		FRANK BENEDETTO		19 CATLIN AVE JAMESTOWN NY 14701	09/17/2018	09/17/2023
DOL	DOL		FRANK BENEDETTO		C/O F & B PAINTING CONTRA 2 PARKVIEW AVENUEHARRISON NY 10604	09/26/2016	09/26/2021
DOL	DOL	****4722	FRANK BENEDETTO AND CHRISTOPHER J MAINI	B & M CONCRETE	19 CAITLIN AVE JAMESTOWN NY 14701	09/17/2018	09/17/2023
DOL	DOL		GABRIEL FRASSETTI			04/10/2019	04/10/2024
DOL	DOL		GALINDA ROTENBERG		C/O GMDV TRANS INC 67-48 182ND STREETFRESH MEADOWS NY 11365	06/24/2016	06/24/2021
DOL	DOL		GEOFF CORLETT		415 FLAGGER AVE #302STUART FL 34994	10/31/2018	10/31/2023
DOL	DA		GEORGE LUCEY		150 KINGS STREET BROOKLYN NY 11231	01/19/1998	01/19/2998
DOL	DOL		GIGI SCHNECKENBURGER		261 MILL RD EAST AURORA NY 14052	05/29/2019	05/29/2024
DOL	DOL	****5674	GMDV TRANS INC		67-48 182ND STREET FRESH MEADOWS NY 11365	06/24/2016	06/24/2021
DOL	NYC		GREAT ESTATE CONSTRUCTION, INC.		327 STAGG ST BROOKLYN NY 11206	10/10/2017	10/10/2022
DOL	DOL		GREGORY S. OLSON		P O BOX 100 200 LATTA BROOK PARKHORSEHEADS NY 14845	03/08/2018	03/08/2023
DOL	NYC		HARMEL SINGH		15 CLINTON LANE HICKSVILLE NY 11801	02/25/2016	02/25/2021
DOL	NYC		HAROLD KUEMMELE		58-83 54TH STREET MASPETH NY 11378	02/26/2016	02/26/2021
DOL	DOL		HENRY VAN DALRYMPLE		2663 LANTERN LANE ATLANTA GA 30349	12/01/2015	12/01/2020
DOL	DOL	****6370	HILLIANO CONSTRUCTION & ELECTRICAL INC		354 MAGNOLIA STREET ROCHESTER NY 14611	01/22/2015	01/22/2020
DOL	DOL	****8282	IDEMA DEVELOPMENT INC		91 COLLEGE AVENUE POUGHKEEPSIE NY 12603	12/04/2015	12/04/2020
DOL	DOL	****8282	IDEMA GENERAL CONTRACTORS INC		91 COLLEGE AVENUE POUGHKEEPSIE NY 12603	12/04/2015	12/04/2020
DOL	DOL	****7001	INTEGRATED CONSTRUCTION & POWER SYSTEMS INC		SUITE 100 2105 W GENESEE STREETS YRACUSE NY 13219	01/06/2016	01/06/2021
DOL	DOL	****5131	INTEGRITY MASONRY, INC.	M&R CONCRETE	722 8TH AVE WATERVLIET NY 12189	06/05/2018	06/05/2023
DOL	DOL		IRENE KASELIS		32 PENNINGTON AVE WALDWICK NJ 07463	05/30/2019	05/30/2024
DOL	AG		J A M CONSTRUCTION CORP		SUITE 125 265 SUNRISE HIGHWAYROCKVILLE CENTRE NY 10457	04/07/2016	04/07/2021
DOL	DOL	****4910	J V MAGIC TOUCH CORPORATION		94-25 57TH AVENUE, APT 5G ELMHURST NY 11373	01/12/2015	01/12/2020
DOL	DOL		J.A. HIRES CADWALLADER		P.O BOX 100 200 LATTA BROOK PARKHORSEHEADS NY 14845	03/08/2018	03/08/2023
DOL	DOL		JAMES B RHYNDERS		91 COLLEGE AVENUE POUGHKEEPSIE NY 12603	12/04/2015	12/04/2020
DOL	DOL		JAMES C. DELGIACCO		722 8TH AVE WATERVLIET NY 12189	06/05/2018	06/05/2023
DOL	DOL		JAMES E RHYNDERS		91 COLLEGE AVENUE POUGHKEEPSIE NY 12603	12/04/2015	12/04/2020
DOL	AG		JAMES FALCONE		SUITE 125 265 SUNRISE HIGHWAYROCKVILLE CENTRE NY 10457	04/07/2016	04/07/2021

NYS DOL Bureau of Public Work Debarment List 08/29/2019

Article 8

DOL	DOL		JAMES LIACONE		9365 WASHINGTON ST LOCKPORT IL 60441	07/23/2018	07/23/2023
DOL	DOL		JAMES RACHEL		9365 WASHINGTON ST LOCKPORT IL 60441	07/23/2018	07/23/2023
DOL	DOL		JAMES RHYNDERS SR		91 COLLEGE AVENUE POUGHKEEPSIE NY 12603	12/04/2015	12/04/2020
DOL	DOL		JAMES SICKAU		3090 SHIRLEY ROAD NORTH COLLINS NY 14111	04/19/2011	07/08/2020
DOL	DOL		JASON W MILLIMAN		C/O ROCHESTER ACOUSTICAL P O BOX 799HILTON NY 14468	02/19/2016	02/19/2021
DOL	DOL	****5368	JCH MASONRY & LANDSCAPING INC.		35 CLINTON AVE OSSINING NY 10562	09/12/2018	09/12/2023
DOL	NYC		JEFFREY CASSIDY		14 RAILROAD AVENUE VALHALLA NY 10595	05/15/2014	04/02/2020
DOL	DOL		JESSICA WHITESIDE		C/O BRRESTORATION NY INC 140 ARCADIA AVENUEOSWEGO NY 13126	09/12/2016	09/12/2021
DOL	AG		JOHN ANTHONY MASSINO		36-49 204TH STREET BAYSIDE NY 11372	02/07/2018	02/07/2023
DOL	DOL		JOHN F. CADWALLADER		200 LATTA BROOK PARK HORSEHEADS NY 14845	03/08/2018	03/08/2023
DOL	DOL	****4612	JOHN F. CADWALLADER, INC.	THE GLASS COMPANY	P O BOX 100 200 LATTA BROOK PARKHORSEHEADS NY 14845	03/08/2018	03/08/2023
DOL	AG	****0600	JOHNCO CONTRACTING, INC.		36-49 204TH STREET BAYSIDE NY 11372	02/07/2018	02/07/2023
DOL	DOL		JON E DEYOUNG		261 MILL RD P.O BOX 296EAST AURORA NY 14052	07/29/2015	07/29/2020
DOL	DOL		JON E DEYOUNG		261 MILL RD P.O BOX 296EAST AURORA NY 14052	05/29/2019	05/29/2024
DOL	DOL		JORGE VILLALOBOS		94-25 57TH AVENUE - APT 5 ELMHURST NY 11373	01/12/2015	01/12/2020
DOL	DOL		JORI PEDERSEN		415 FLAGER AVE #302STUART FL 34994	10/31/2018	10/31/2023
DOL	DOL		JOSE CHUCHUCA		35 CLINTON AVE OSSINING NY 10562	09/12/2018	09/12/2023
DOL	DOL		JOSE MONTAS		27 BUTLER PLACE YONKERS NY 10710	03/18/2011	03/19/2020
DOL	AG		JOSEPH FALCONE		SUITE 125 265 SUNRISE HIGHWAYROCKVILLE CENTRE NY 10457	04/07/2016	04/07/2021
DOL	DOL	****9273	JOSEPH M LOVETRO		P O BOX 812 BUFFALO NY 14220	08/09/2016	08/09/2021
DOL	NYC		JOSEPH MARTINO		1535 RICHMOND AVENUE STATEN ISLAND NY 10314	12/13/2017	12/13/2022
DOL	DOL		JOSEPH MARTONE		112 OSCAWANA HEIGHTS RD PUTNAM VALLEY NY 10542	03/13/2015	03/13/2020
DOL	DOL		JUANA MARTINEZ		C/O LEAD CONSTRUCTION 27 BUTLER PLACEYONKERS NY 10710	03/19/2015	03/19/2020
DOL	DOL		JULIUS AND GITA BEHREND		5 EMES LANE MONSEY NY 10952	11/20/2002	11/20/3002
DOL	DOL	****5062	K R F SITE DEVELOPMENT INC		375 LAKE SHORE DRIVE PUTNAM VALLEY NY 10579	01/23/2017	01/23/2022
DOL	DOL		KATIE BURDICK		2238 BAKER RD GILLET PA 16923	03/12/2018	03/12/2023
DOL	DOL		KENNETH FIORENTINO		375 LAKE SHORE DRIVE PUTNAM VALLEY NY 10579	01/23/2017	01/23/2022
DOL	DOL	****9732	KENT HOLLOW SIDING LLC		29A BRIDGE STREET NEW MILFORD CT 06776	01/15/2016	01/15/2021
DOL	DOL		KIM SOROCENSKI		C/O SOLUTION MATTERS INC 198 NORWOOD ROADPORT JEFFERSON NY 11776	11/19/2015	11/19/2020
DOL	DOL	****3490	L & M CONSTRUCTION/DRYWALL INC.		1079 YONKERS AVE YONKERS NY 10704	08/07/2018	08/07/2023
DOL	DA	****8816	LAKE CONSTRUCTION AND DEVELOPMENT CORPORATION		150 KINGS STREET BROOKLYN NY 11231	08/19/1998	08/19/2998
DOL	DOL	****6224	LAKESIDE FIRE SPRINKLERS LLC		125 CHAUTAUQUA AVENUE LAKEWOOD NY 14750	06/24/2015	06/24/2020
DOL	AG	****4643	LALO DRYWALL, INC.		221 OLD FORD ROAD NEW PLATZ NY 12561	05/20/2016	05/20/2021

NYS DOL Bureau of Public Work Debarment List 08/29/2019

Article 8

DOL	DOL	****4505	LARAPINTA ASSOCIATES INC		29 MAPLEWOOD DRIVE BINGHAMTON NY 13901	02/21/2017	02/21/2022
DOL	DOL		LAURI MARTONE		112 OSCAWANA HEIGHTS RD PUTNAM VALLEY NY 10542	03/13/2015	03/13/2020
DOL	DOL		LAVERN GLAVE		161 ROBYN RD MONROE NY 10950	09/15/2014	09/15/2019
DOL	DOL		LAVERN GLAVE		161 ROBYN RD MONROE NY 10950	01/30/2018	01/30/2023
DOL	DOL	****1364	LEAD CONSTRUCTION SERVICES INC		3 ALAN B SHEPARD PLACE YONKERS NY 10705	03/19/2015	03/19/2020
DOL	DOL	****4388	LEN.J CONSTRUCTION, LLC		PO BOX 10007 ALBANY NY 12201	06/24/2016	09/19/2022
DOL	DOL	****4388	LEN.J CONSTRUCTION, LLC		PO BOX 10007 ALBANY NY 12201	06/24/2016	09/19/2022
DOL	DOL	****4388	LEN.J CONSTRUCTION, LLC		PO BOX 10007 ALBANY NY 12201	09/19/2017	09/19/2022
DOL	DOL	****4388	LEN.J CONSTRUCTION, LLC		PO BOX 10007 ALBANY NY 12201	09/19/2017	09/19/2022
DOL	DOL	****4388	LEN.J CONSTRUCTION, LLC		PO BOX 10007 ALBANY NY 12201	01/17/2017	09/19/2022
DOL	DOL	****4388	LEN.J CONSTRUCTION, LLC		PO BOX 10007 ALBANY NY 12201	09/19/2017	09/19/2022
DOL	DOL	****4388	LEN.J CONSTRUCTION, LLC		PO BOX 10007 ALBANY NY 12201	09/19/2017	09/19/2022
DOL	DOL	****4388	LEN.J CONSTRUCTION, LLC		PO BOX 10007 ALBANY NY 12201	08/14/2017	09/19/2022
DOL	DOL		LEROY NELSON JR		PO BOX 10007 ALBANY NY 12201	09/19/2017	09/19/2022
DOL	DOL		LEROY NELSON JR		PO BOX 10007 ALBANY NY 12201	09/19/2017	09/19/2022
DOL	DOL		LEROY NELSON JR		PO BOX 10007 ALBANY NY 12201	09/19/2017	09/19/2022
DOL	DOL		LEROY NELSON JR		PO BOX 10007 ALBANY NY 12201	09/19/2017	09/19/2022
DOL	DOL		LEROY NELSON JR		PO BOX 10007 ALBANY NY 12201	08/14/2017	08/14/2022
DOL	DOL		LEROY NELSON JR		PO BOX 10007 ALBANY NY 12201	01/17/2017	09/19/2022
DOL	DOL		LINDSEY R CRILL		143 FILLMORE AVENUE BUFFALO NY 14210	01/08/2015	01/08/2020
DOL	DA	****4460	LONG ISLAND GLASS & STOREFRONTS, LLC		4 MANHASSET TRL RIDGE NY 11961	09/06/2018	09/06/2023
DOL	AG	****4216	LOTUS-C CORP.		81-06 34TH AVENUE APT. 6EJACKSON HEIGHTS NY 11372	02/07/2018	02/07/2023
DOL	AG		LUIS MARTINEZ	LALO DRYWALL	211 MAIN ST. NEW PALTZ NY 12561	05/20/2016	05/20/2021
DOL	DOL		M ANVER BEIG		142 EAST MARKET STREET LONG BEACH NY 11561	03/07/2017	03/07/2022
DOL	AG	****6957	M B DIN CONSTRUCTION INC		8831 20TH AVENUE/SUITE 6E BROOKLYN NY 11214	11/17/2015	11/17/2020
DOL	NYC	****6317	M S QUALITY CONSTRUCTION LLC		27 MAPLEWOOD AVENUE COLONIA NJ 07067	02/04/2015	02/04/2020
DOL	DOL		M. ANVER BEIG		142 EAST MARKET STREET LONG BEACH NY 11561	03/07/2017	03/07/2022
DOL	NYC		MACIEJ SONTOWSKI		27 MAPLEWOOD AVENUE COLONIA NJ 07067	02/04/2015	02/04/2020
DOL	NYC	****9590	MACK GLASSNAUTH IRON WORKS INC		137 LIBERTY AVENUE BROOKLYN NY 11212	12/21/2015	12/21/2020
DOL	DOL	****1784	MADISON AVE CONSTRUCTION CORP		39 PENNY STREET WEST ISLIP NY 11795	11/02/2016	11/02/2021
DOL	DOL		MALARKEY'S BAR & GRILL LLC		64 VICTORIA DRIVE BINGHAMTON NY 13904	02/04/2016	02/04/2021
DOL	DOL	****0705	MALARKEY'S PUB & GRUB LLC		64 VICTORIA DRIVE BINGHAMTON NY 13904	02/04/2016	02/04/2021
DOL	DA		MANUEL P TOBIO		150 KINGS STREET BROOKLYN NY 14444	08/19/1998	08/19/2998
DOL	DA		MANUEL TOBIO		150 KINGS STREET BROOKLYN NY 11231	08/19/1998	08/19/2998
DOL	NYC		MAREK FABIJANOWSKI		50 MAIN ST WHITE PLAINS NY 10606	01/04/2019	01/04/2024
DOL	DOL		MARIACHI'S PIZZERIA		C/O DOUGLAS L MALARKEY 64 VICTORIA DRIVEBINGHAMTON NY 13904	02/04/2016	02/04/2021
DOL	DOL		MARK MIONIS		6409 LAND O LAKES BLVD LAND O LAKES FL 34638	11/10/2015	11/10/2020

NYS DOL Bureau of Public Work Debarment List 08/29/2019

Article 8

DOL	DOL		MARVIN A STURDEVANT		29 MAPLEWOOD DRIVE BINGHAMTON NY 13901	02/21/2017	02/21/2022
DOL	DOL		MASONRY CONSTRUCTION, INC.		442 ARMONK RD MOUNT KISCO NY 10549	06/12/2018	06/12/2023
DOL	DOL	****3333	MASONRY INDUSTRIES, INC.		442 ARMONK RD MOUNT KISCO NY 10549	06/12/2018	06/12/2023
DOL	DOL		MATTHEW IDEMA GENERAL CONTRACTORS INC		91 COLLEGE AVENUE POUGHKEEPSIE NY 12603	12/04/2015	12/04/2020
DOL	DOL		MATTHEW P. KILGORE		4156 WILSON ROAD EAST TABERG NY 13471	03/26/2019	03/26/2024
DOL	DOL		MAURICE GAWENO		442 ARMONK RD MOUNT KISCO NY 10549	06/12/2018	06/12/2023
DOL	DOL	****6416	MCCALL MASONRY		P O BOX 304 SAYRE PA 18840	08/09/2016	08/09/2021
DOL	DOL		MCLEAN "MIKKI BEANE"		1229 JAMES STREET SYRACUSE NY 13203	05/02/2017	05/02/2022
DOL	DOL		MCLEAN "MIKKI" DRAKE		1229 JAMES STREET SYRACUSE NY 13203	05/02/2017	05/02/2022
DOL	DOL		MCLEAN M DRAKE-BEANE		1229 JAMES STREET SYRACUSE NY 13203	05/02/2017	05/02/2022
DOL	DOL	****9445	MCLEAN M WALSH	ELITE PROFESSION AL PAINTING OF CNY	1229 JAMES STREET SYRACUSE NY 13203	05/02/2017	05/02/2022
DOL	DOL	****9445	MCLEAN M WALSH	ELITE PROFESSION AL PAINTING OF CNY	1229 JAMES STREET SYRACUSE NY 13203	05/02/2017	05/02/2022
DOL	NYC	****5330	METRO DUCT SYSTEMS INC		1219 ASTORIA BOULEVARD LONG ISLAND CITY NY 11102	04/16/2014	11/19/2020
DOL	DOL	****3368	MICEK CONSTRUCTION CO INC		20 CROSS STREET FALCONER NY 14733	12/02/2014	12/02/2019
DOL	DOL		MICHAEL A PASCARELLA		SUITE 100 2105 WEST GENESEE STREET SYRACUSE NY 13219	01/06/2016	01/06/2021
DOL	NYC		MICHAEL HIRSCH		C/O MZM CORP 163 S MAIN STREET NEW CITY NY 10956	01/28/2016	01/28/2021
DOL	DOL		MICHAEL LENIHAN		1079 YONKERS AVE UNIT 4 YONKERS NY 10704	08/07/2018	08/07/2023
DOL	AG		MICHAEL RIGLIETTI		31 BAY ST BROOKLYN NY 11231	03/28/2018	03/28/2023
DOL	DOL		MICHAEL WILSON	WILSON BROTHER DRYWALL CONTRACTOR S	36 ABERSOLD STREET ROCHESTER NY 14621	08/31/2015	08/31/2020
DOL	NYC		MILANCE HADZIC		22 CALIFORNIA AVE - STE 1 PATERSON NJ 07503	03/11/2015	03/11/2020
DOL	DOL	****4829	MILESTONE ENVIRONMENTAL CORPORATION		704 GINESI DRIVE SUITE 29 MORGANVILLE NJ 07751	04/10/2019	04/10/2024
DOL	AG		MOHAMMED N CHATHA		8831 20TH AVENUE/SUITE 6E BROOKLYN NY 11214	11/17/2015	11/17/2020
DOL	DOL	****2737	MOUNTAIN'S AIR INC		2471 OCEAN AVENUE- STE 7A BROOKLYN NY 11229	09/24/2012	09/18/2020
DOL	AG		MSR ELECTRICAL CONSTRUCTION CORP.		31 BAY ST BROOKLYN NY 11231	03/28/2018	03/28/2023
DOL	DOL		MUHAMMAD BEIG		142 EAST MARKET STREET LONG BEACH NY 11561	03/07/2017	03/07/2022
DOL	DOL		MUHAMMAD BEIG		142 EAST MARKET STREET LONG BEACH NY 11561	03/07/2017	03/07/2022
DOL	DOL		MUHAMMAD PERVAIZ		C/O CHAMPION CONSTRUCTION 2131 SCHENECTADY AVENUE BROOKLYN NY 11234	11/18/2015	11/18/2020
DOL	NYC	****3613	MZM CORP		163 S MAIN STREET NEW CITY NY 10956	01/28/2016	01/28/2021
DOL	DA	****9786	NATIONAL INSULATION & GC CORP		180 MILLER PLACE HICKSVILLE NY 11801	12/12/2018	12/12/2023
DOL	NYC	****1284	NEW AMERICAN RESTORATION INC		22 CALIFORNIA AVE - STE 1 PATERSON NJ 07503	03/11/2015	03/11/2020
DOL	DA	****6988	NEW YORK INSULATION INC		58-48 59TH STREET MASPETH NY 11378	05/16/2012	05/08/2020
DOL	NYC	****4839	NEW YORK RIGGING CORP		58-83 54TH STREET MASPETH NY 11378	02/26/2016	02/26/2021
DOL	NYC	****1968	NORTH AMERICAN IRON WORKS INC		1560 DECATUR STREET RIDGEMOUNT NY 11385	05/15/2015	05/15/2020

NYS DOL Bureau of Public Work Debarment List 08/29/2019

Article 8

DOL	DOL	****6966	NORTH COUNTRY DRYWALL AND PAINT		23167 COUNTY ROUTE 59 DEXTER NY 13634	10/24/2016	10/24/2021
DOL	DOL	****0065	NORTHEAST LANDSCAPE AND MASONRY ASSOC		3 WEST MAIN ST/SUITE 208 ELMSFORD NY 10523	01/23/2017	01/23/2022
DOL	DOL	****1845	OC ERECTERS, LLC A/K/A OC ERECTERS OF NY INC.		1207 SW 48TH TERRACE DEERFIELD BEACH FL 33442	01/16/2018	01/16/2023
DOL	NYC		ORSON ARROYO		C/O METRO DUCT SYSTEMS 12-19 ASTORIA BOULEVARDLONG ISLAND CITY NY 11102	04/16/2014	11/19/2020
DOL	NYC	****9422	PELIUM CONSTRUCTION, INC.		22-33 35TH ST. ASTORIA NY 11105	12/30/2016	12/30/2021
DOL	DOL		PETER M PERGOLA		3 WEST MAIN ST/SUITE 208 ELMSFORD NY 10523	01/23/2017	01/23/2022
DOL	DOL		PIERRE LAPORT		224 COUNTY HIGHWAY 138 BROADALBIN NY 12025	03/07/2017	03/07/2022
DOL	DOL	****1543	PJ LAPORT FLOORING INC		224 COUNTY HIGHWAY 138 BROADALBIN NY 12025	03/07/2017	03/07/2022
DOL	DOL	****6895	PROLINE CONCRETE OF WNY INC		3090 SHIRLEY ROAD NORTH COLLINS NY 14111	04/19/2011	07/08/2020
DOL	DA	****6817	QUADRANT METAL BUILDINGS LLC		2740 SW MARTIN DOWNS BLVD PALM CITY FL 34990	08/25/2016	08/25/2021
DOL	NYC		RAMESHWAR ASU		137 LIBERTY AVENUE BROOKLYN NY 11212	12/21/2015	12/21/2020
DOL	DOL		RANA A KAHN		1973 81ST ST - SUITE A-5 BROOKLYN NY 11214	01/08/2015	01/08/2020
DOL	NYC		RANTIK PARIKH		13 LORIANN ROAD WARREN NJ 07059	07/15/2015	07/15/2020
DOL	DOL	****2633	RAW POWER ELECTRIC CORP		3 PARK CIRCLE MIDDLETOWN NY 10940	09/16/2013	09/15/2019
DOL	DOL	****2633	RAW POWER ELECTRIC CORP		3 PARK CIRCLE MIDDLETOWN NY 10940	01/30/2018	01/30/2023
DOL	AG	****7015	RCM PAINTING INC.		69-06 GRAND AVENUE 2ND FLOORMASPETH NY 11378	02/07/2018	02/07/2023
DOL	DOL		REGINALD WARREN		161 ROBYN RD MONROE NY 10950	09/15/2014	09/15/2019
DOL	DOL		REGINALD WARREN		161 ROBYN RD MONROE NY 10950	01/30/2018	01/30/2023
DOL	NYC	****3461	RELIANCE GENERAL CONSTRUCTION INC		644 OCEAN PARKWAY BROOKLYN NY 11230	09/02/2015	09/02/2020
DOL	DA		RIANN MULLER		2740 SW MARTIN DOWNS BLVD PALM CITY FL 34990	08/25/2016	08/25/2021
DOL	DOL	****9148	RICH T CONSTRUCTION		107 WILLOW WOOD LANE CAMILLUS NY 13031	11/13/2018	11/13/2023
DOL	DOL		RICHARD MACONE		8617 THIRD AVE BROOKLYN NY 11209	09/17/2018	09/17/2023
DOL	DOL	****9148	RICHARD TIMIAN	RICH T CONSTRUCTI ON	108 LAMONT AVE SYRACUSE NY 13209	10/16/2018	10/16/2023
DOL	DOL		RICHARD TIMIAN JR.		108 LAMONT AVE SYRACUSE NY 13209	10/16/2018	10/16/2023
DOL	DOL		RICHARD TIMIAN JR.		108 LAMONT AVE SYRACUSE NY 13209	11/13/2018	11/13/2023
DOL	DOL	****8618	RIEKS CONTRACTING LLC		4804 GAHWILER ROAD AUBURN NY 13021	05/01/2015	05/01/2020
DOL	DOL		ROBBYE BISSEAR		89-51 SPRINGFIELD BLVD QUEENS VILLAGE NY 11427	01/11/2003	01/11/3003
DOL	DOL		ROBERT A. VALERINO		3841 LANYARD COURT NEW PORT RICHEY FL 34652	07/09/2019	07/09/2024
DOL	DOL		ROBERT BRUNO		3 GAYLORD ST AUBURN NY 13021	11/15/2016	11/15/2021
DOL	DOL		ROBERT BRUNO		5 MORNINGSIDE DRIVE AUBURN NY 13021	05/28/2019	05/28/2024
DOL	DOL		ROBERT TORDELLA		125 CHAUTAUQUA AVENUE LAKEWOOD NY 14750	06/24/2015	06/24/2020
DOL	DOL	****3859	ROCHESTER ACOUSTICAL CORP		P O BOX 799 HILTON NY 14468	02/19/2016	02/19/2021
DOL	DOL		RODERICK PUGH		404 OAK ST SUITE 101SYRACUSE NY 13203	07/23/2018	07/23/2023
DOL	DOL	****4880	RODERICK PUGH CONSTRUCTION INC.		404 OAK ST SUITE 101SYRACUSE NY 13203	07/23/2018	07/23/2023
DOL	NYC		RODNEY SCOTT		201 HEMPSTEAD AVENUE WEST HEMPSTEAD NY 11552	10/30/2015	10/30/2020

NYSDOL Bureau of Public Work Debarment List 08/29/2019

Article 8

DOL	DOL		ROMEO WARREN		161 ROBYN RD MONROE NY 10950	09/16/2013	09/15/2019
DOL	DOL		ROMEO WARREN		161 ROBYN RD MONROE NY 10950	01/30/2018	01/30/2023
DOL	DOL		ROSEANNE CANTISANI			06/12/2018	06/12/2023
DOL	DOL		RYAN ALBIE		21 S HOWELLS POINT ROAD BELLPORT NY 11713	02/21/2017	02/21/2022
DOL	DOL	****3347	RYAN ALBIE CONTRACTING INC		21 S HOWELLS POINT ROAD BELLPORT NY 11713	02/21/2017	02/21/2022
DOL	DOL	****1365	S & L PAINTING, INC.		11 MOUNTAIN ROAD P.O BOX 408MONROE NY 10950	03/20/2019	03/20/2024
DOL	NYC		SABIR MUHAMMED		SUITE B-8 782 PELHAM PARKWAY SOUTHBRONX NY 10462	04/21/2016	04/21/2021
DOL	DOL	****9874	SALFREE ENTERPRISES INC		2821 GARDNER ROAD POMPEY NY 13138	08/26/2016	08/26/2021
DOL	DOL		SALVATORE A FRESINA			08/26/2016	08/26/2021
DOL	DOL		SAM FRESINA			08/26/2016	08/26/2021
DOL	NYC	****2117	SCOTT ELECTRICAL LLC		201 HEMPSTEAD AVENUE WEST HEMPSTEAD NY 11552	10/30/2015	10/30/2020
DOL	DOL	****9751	SCW CONSTRUCTION		544 OLD ROUTE 23 ACRE NY 12405	02/14/2017	02/14/2022
DOL	AG		SERGIO RAYMUNDO		109 DUBOIS RD. NEW PALTZ NY 12561	05/20/2016	05/20/2021
DOL	NYC	****6597	SHAIRA CONSTRUCTION CORP.		421 HUDSON STREET SUITE C5NEW YORK NY 10014	02/20/2019	02/20/2024
DOL	DOL	****1961	SHANE BURDICK	CENTRAL TRAFFIC CONTROL, LLC.	2238 BAKER ROAD GILLETT PA 16923	03/12/2018	03/12/2023
DOL	DOL		SHANE BURDICK		2238 BAKER ROAD GILLETT PA 16923	03/12/2018	03/12/2023
DOL	DOL		SHANE NOLAN		9365 WASHINGTON ST LOCKPORT IL 60441	07/23/2018	07/23/2023
DOL	DOL		SHULEM LOWINGER		11 MOUNTAIN ROAD 28 VAN BUREN DRMONROE NY 10950	03/20/2019	03/20/2024
DOL	DOL	****0816	SOLAR ARRAY SOLUTIONS, LLC		9365 WASHINGTON ST LOCKPORT IL 60441	07/23/2018	07/23/2023
DOL	DOL	****4025	SOLUTION MATTERS INC		198 NORWOOD ROAD PORT JEFFERSON NY 11776	11/19/2015	11/19/2020
DOL	DOL	****3496	STAR INTERNATIONAL INC		89-51 SPRINGFIELD BLVD QUEENS VILLAGE NY 11427	08/11/2003	08/11/3003
DOL	DOL	****9933	STEED GENERAL CONTRACTORS, INC.		1445 COMMERCE AVE BRONX NY 10461	05/30/2019	05/30/2024
DOL	DOL		STEFANOS PAPASTEFANOU, JR. A/K/A STEVE PAPASTEFANOU, JR.		256 WEST SADDLE RIVER RD UPPER SADDLE RIVER NJ 07458	05/30/2019	05/30/2024
DOL	DOL	****9751	STEPHEN C WAGAR		544 OLD ROUTE 23 ACRE NY 12405	02/14/2017	02/14/2022
DOL	DOL		STEVE TATE		415 FLAGER AVE #302STUART FL 34994	10/31/2018	10/31/2023
DOL	DOL		STEVEN P SUCATO		15-68 208TH STREET BAYSIDE NY 11360	06/23/2016	06/23/2021
DOL	DOL		STEVEN TESTA		50 SALEM STREET - BLDG B LYNNFIELD MA 01940	01/23/2017	01/23/2022
DOL	NYC	****9432	SUBLINK LTD		346 THIRD AVENUE PELHAM NY 10803	11/19/2015	11/19/2020
DOL	DOL	****1060	SUNN ENTERPRISES GROUP, LLC		370 W. PLEASANTVIEW AVE SUITE 2.329HACKENSACK NJ 07601	02/11/2019	02/11/2024
DOL	DOL	****8209	SYRACUSE SCALES, INC.		158 SOLAR ST SYRACUSE NY 13204	01/07/2019	01/07/2024
DOL	DOL	****7441	T & T CONCRETE INC		2560 HAMBURG TURNPIKE P O BOX 367LACKAWANNA NY 14218	07/08/2015	07/08/2020
DOL	DOL		TALAILA OCAMPA		1207 SW 48TH TERRACE DEERFIELD BEACH FL 33442	01/16/2018	01/16/2023
DOL	DOL	****9852	TAP STEEL INC		ROUTE 26 3101 P O BOX 457CONSTABLEVILLE NY 13325	01/28/2016	01/28/2021
DOL	DOL	****5570	TESTA CORP		50 SALEM STREET - BLDG B LYNNFIELD MA 01940	01/23/2017	01/23/2022

NYS DOL Bureau of Public Work Debarment List 08/29/2019

Article 8

DOL	DOL	****0887	THE BRINSON PAINTING CORPORATION		72 TAUNTON PLACE BUFFALO NY 14216	04/14/2015	04/14/2020
DOL	DOL	****5766	THE COKER CORPORATION	COKER CORPORATION	2610 SOUTH SALINA ST SUITE 14SYRACUSE NY 13205	12/04/2018	12/04/2023
DOL	DOL	****8174	THE DALRYMPLE CORPORATION		UNIT 278 541 10TH STREET NWLANTA GA 30318	12/01/2015	12/01/2020
DOL	DOL	****8174	THE DALRYMPLE GROUP LLC		289 JONESBORO RD/ STE 216 MCDONOUGH GA 30253	12/01/2015	12/01/2020
DOL	DOL		TIMOTHY A PALUCK		C/O TAP STEEL INC RTE 26 3101/ P O BOX 457CONSTABLEVILLE NY 13325	01/28/2016	01/28/2021
DOL	DOL	****0600	TOMSON ALLOYS RECYCLING INC		143 FILLMORE AVENUE BUFFALO NY 14210	01/08/2015	01/08/2020
DOL	DOL	****3453	TORCHIA'S HOME IMPROVEMENT		10153 ROBERTS RD SAUQUOIT NY 13456	08/09/2016	08/09/2021
DOL	DOL	****8311	TRIPLE B FABRICATING, INC.		61 WILLETT ST. PASSAIC NJ 07503	10/26/2016	10/26/2021
DOL	DOL	****9407	TURBO GROUP INC		15-68 208TH STREET BAYSIDE NY 11360	06/23/2016	06/23/2021
DOL	DOL	****6392	V.M.K CORP.		8617 THIRD AVE BROOKLYN NY 11209	09/17/2018	09/17/2023
DOL	NYC		VALERIE VISCONTI		346 THIRD AVENUE PELHAM NY 10803	11/19/2015	11/19/2020
DOL	DOL		VICTOR ALICANTI		42-32 235TH ST DOUGLSTON NY 11363	01/14/2019	01/14/2024
DOL	DOL		VICTOR ROTENBERG		C/O GMDV TRANS INC 67048 182ND STREETFRESH MEADOWS NY 11365	06/24/2016	06/24/2021
DOL	NYC		VIKTAR PATONICH		2630 CROPSEY AVE BROOKLYN NY 11214	10/30/2018	10/30/2023
DOL	NYC		VITO GARGANO		1535 RICHMOND AVE STATEN ISLAND NY 10314	12/13/2017	12/13/2022
DOL	DOL		WAYNE LIVINGSTON JR	NORTH COUNTRY DRYWALL AND PAINT	23167 COUNTY ROUTE 59 DEXTER NY 13634	10/24/2016	10/24/2021
DOL	DOL	****3296	WESTERN NEW YORK CONTRACTORS, INC.		3841 LAYNARD COURT NEW PORT RICHEY FL 34652	07/09/2019	07/09/2024
DOL	DOL		WHITE PLAINS CARPENTRY CORP		442 ARMONK RD	06/12/2018	06/12/2023
DOL	DOL		WILLIAM C WATKINS		1229 JAMES STREET SYRACUSE NY 13203	05/02/2017	05/02/2022
DOL	DOL		WILLIAM DEAK		C/O MADISON AVE CONSTR CO 39 PENNY STREETWEST ISLIP NY 11795	11/02/2016	11/02/2021
DOL	DOL		WILLIE BRINSON		72 TAUNTON PLACE BUFFALO NY 14216	04/14/2015	04/14/2020
DOL	DOL	****6195	WILSON BROTHER DRYWALL CONTRACTORS		36 ABERSOLD STREET ROCHESTER NY 14621	08/31/2015	08/31/2020
DOL	DOL	****4043	WINDSHIELD INSTALLATION NETWORK, INC.		200 LATTA BROOK PARK HORSEHEADS NY 14845	03/08/2018	03/08/2023
DOL	DOL	****4730	XGD SYSTEMS, LLC	TDI GOLF	415 GLAGE AVE #302STUART FL 34994	10/31/2018	10/31/2023
DOL	DOL	****7345	YES SERVICE AND REPAIRS CORPORATION		145 LODGE AVE HUNTINGTON STATION NY 11476	08/09/2016	08/09/2021
DOL	DOL		YURIY IVANIN		C/O MOUNTAIN'S AIR INC 2471 OCEAN AVENUE-STE 7ABROOKLYN NY 11229	09/24/2012	09/18/2020
DOL	NYC		ZAKIR NASEEM		30 MEADOW ST BROOKLYN NY 11206	10/10/2017	10/10/2022
DOL	NYC	****8277	ZHN CONTRACTING CORP		30 MEADOW ST BROOKLYN NY 11206	10/10/2017	10/10/2022

"General Decision Number: NY20190008 11/22/2019

Superseded General Decision Number: NY20180008

State: New York

Construction Types: Heavy and Highway

Counties: Cattaraugus, Chautauqua and Erie Counties in New York.

HEAVY CONSTRUCTION PROJECTS: CHAUTAUQUA AND ERIE COUNTIES; AND
HIGHWAY CONSTRUCTION PROJECTS: CATTARAUGUS, CHAUTAUQUA AND
ERIE COUNTIES

Note: Under Executive Order (EO) 13658, an hourly minimum wage of \$10.60 for calendar year 2019 applies to all contracts subject to the Davis-Bacon Act for which the contract is awarded (and any solicitation was issued) on or after January 1, 2015. If this contract is covered by the EO, the contractor must pay all workers in any classification listed on this wage determination at least \$10.60 per hour (or the applicable wage rate listed on this wage determination, if it is higher) for all hours spent performing on the contract in calendar year 2019. If this contract is covered by the EO and a classification considered necessary for performance of work on the contract does not appear on this wage determination, the contractor must pay workers in that classification at least the wage rate determined through the conformance process set forth in 29 CFR 5.5(a)(1)(ii) (or the EO minimum wage rate, if it is higher than the conformed wage rate). The EO minimum wage rate will be adjusted annually. Please note that this EO applies to the above-mentioned types of contracts entered into by the federal government that are subject to the Davis-Bacon Act itself, but it does not apply to contracts subject only to the Davis-Bacon Related Acts, including those set forth at 29 CFR 5.1(a)(2)-(60). Additional information on contractor requirements and worker protections under the EO is available at www.dol.gov/whd/govcontracts.

Modification Number	Publication Date
0	01/04/2019
1	01/18/2019
2	03/01/2019
3	04/05/2019
4	06/14/2019
5	06/21/2019
6	08/09/2019
7	08/16/2019
8	09/27/2019
9	11/22/2019

ASBE0004-001 05/01/2019

	Rates	Fringes
ASBESTOS WORKER/HEAT & FROST INSULATOR (include application of all materials, protective coverings, coatings, and finishings to all types of mechanical systems).....	\$ 33.70	23.84
HAZARDOUS MATERIAL HANDLER.....	\$ 33.70	23.84

BOIL0007-001 01/01/2017

	Rates	Fringes
BOILERMAKER.....	\$ 33.00	28.15

BRNY0008-004 07/01/2018

CHATAUQUA COUNTY AND CATTARAUGUS COUNTY (EXCLUDING TWNSP OF
PERRYSBURG)

	Rates	Fringes
CEMENT MASON/CONCRETE FINISHER...	\$ 30.91	20.62

BRNY0045-001 07/01/2018

ERIE, CATTARAUGUS (Towns of Perrysburg & Gowanda)

	Rates	Fringes
Bricklayer, Stonemason.....	\$ 31.32	25.58
Cement mason.....	\$ 31.32	25.58
MARBLE SETTER.....	\$ 31.21	20.54
TERRAZZO FINISHER.....	\$ 29.13	15.12
TILE FINISHER.....	\$ 29.13	15.12
Tilesetter & Terrazzo Worker.....	\$ 31.21	20.54

 CARP0276-002 07/01/2019

CHAUTAUQUA; CATTARAUGUS (Remainder of County).

	Rates	Fringes
Carpenters:.....	\$ 31.23	22.75+a

FOOTNOTES:

a. Paid Holidays: Independence Day and Labor Day, provided the employee works his scheduled day before and after the holiday and is on the payroll week in which the holiday falls.

 CARP0276-013 07/01/2019

CATTARAUGUS (Townships of Persia and Perrysburg) ERIE (Grand Island)

	Rates	Fringes
CARPENTER		
Heavy & Highway.....	\$ 34.60	28.76

FOOTNOTES:

a. PAID HOLIDAYS: Independence Day, Labor Day, provided the employee works his scheduled day before and after the holiday and is on the payroll in the payroll week in which the holiday falls.

CARP0276-021 07/01/2019

CATTARAUGUS (Townships of Persia and Perrysburg)

	Rates	Fringes
CARPENTER		
Heavy & Highway.....	\$ 31.23	22.75

FOOTNOTES:

- a. PAID HOLIDAYS: Independence Day, Labor Day, provided the employee works his scheduled day before and after the holiday and is on the payroll in the payroll week in which the holiday falls.

ELEC0041-007 05/27/2019

ERIE, CATTARAUGUS (Ashford, East Otto, Ellicottville, Farmersville, Freedom, Franklinville, Lyndon, Machias, Mansfield, New Albion, Otto, Perrysburg, Persia and Yorkshire Townships)

	Rates	Fringes
CABLE SPLICER.....	\$ 36.73	3%+22.29
ELECTRICIAN.....	\$ 35.64	29.16

ELEC0041-008 05/27/2019

ERIE, CATTARAUGUS (Ashford, East Otto, Ellicottville, Farmersville, Freedom, Franklinville, Lyndon, Machias, Mansfield, New Albion, Otto, Perrysburg, Persia and Yorkshire Townships)

	Rates	Fringes
Communications System		
CABLER.....	\$ 11.10	11.97+a
INSTALLER.....	\$ 18.35	18.44+a
MASTER TECHNICIAN.....	\$ 28.05	18.73+a

SOUND WIREMAN.....\$ 25.50 18.66+a

Work covers low voltage construction, installation, maintenance, and removal of teledata facilities (voice, data and video) including outside plant, telephone and data inside wire, interconnect, terminal equipment, central offices, PABX fiber optic cable and equipment, railroad communications, micro waves, V-Sat, bypass, CATV, WAN (wide area networks); LAN (local area networks) and ISDN (integrated systems digital network). Also, installation of sound systems, nurses call systems, intercom systems, staff registry/locating/signaling systems, antenna systems and associated devices; installation of security systems and apparatus, and cabling from VDT's to computers. This work does not apply to new construction, or to the installation of raceway systems and boxes for the above work.

FOOTNOTE:

a. Paid Holidays: New Year's Day, Memorial Day, Independence Day, Labor Day, Thanksgiving Day, the day after Thanksgiving Day, Christmas Day.

 ELEC0106-002 01/01/2019

CHAUTAUQUA, CATTARAUGUS (Remainder of County)

	Rates	Fringes
CABLE SPLICER.....	\$ 35.75	20.68
ELECTRICIAN.....	\$ 36.51	23.4353

 ELEC1249-003 05/06/2019

	Rates	Fringes
ELECTRICIAN (LINE CONSTRUCTION: LIGHTING AND TRAFFIC SIGNAL Including any and all Fiber Optic Cable necessary for Traffic Signal Systems, Traffic Monitoring systems and Road Weather		

information systems)

Flagman.....	\$ 27.00	6.75%+24.15
Groundman (Truck Driver)....	\$ 36.00	6.75%+24.15
Groundman Truck Driver (tractor trailer unit).....	\$ 36.00	6.75%+24.15
Lineman & Technician.....	\$ 45.00	6.75%+24.15
Mechanic.....	\$ 36.00	6.75%+24.15

FOOTNOTE:

a. New Year's Day, Memorial Day, Independence Day, Labor Day, Thanksgiving Day, Christmas Day, plus President's Day, Good Friday, Decoration Day, Election Day for the President of the United States and Election Day for the Governor of the State of New York, provided the employee works the day before or the day after the holiday.

 ELEC1249-004 05/06/2019

Rates Fringes

ELECTRICIAN (Line Construction)

Overhead and underground distribution and maintenance work and all overhead and underground transmission line work including any and all fiber optic ground wire, fiber optic shield wire or any other like product by any other name manufactured for the dual purpose of ground fault protection and fiber optic capabilities :

Flagman.....	\$ 31.23	6.75%+24.15
Groundman digging machine operator.....	\$ 46.85	6.75%+24.15
Groundman truck driver (tractor trailer unit)....	\$ 41.64	6.75%+24.15
Groundman Truck driver....	\$ 41.64	6.75%+24.15
Lineman and Technician....	\$ 52.05	6.75%+24.15

Mechanic.....	\$ 41.64	6.75%+24.15
Substation:		
Cable Splicer.....	\$ 57.26	6.75%+24.15
Flagman.....	\$ 31.23	6.75%+24.15
Ground man truck driver....	\$ 41.64	6.75%+24.15
Groundman digging machine operator.....	\$ 46.85	6.75%+24.15
Groundman truck driver (tractor trailer unit)....	\$ 41.64	6.75%+24.15
Lineman & Technician.....	\$ 52.05	6.75%+24.15
Mechanic.....	\$ 41.64	6.75%+24.15
Switching structures; railroad catenary installation and maintenance, third rail type underground fluid or gas filled transmission conduit and cable installations (including any and all fiber optic ground product by any other name manufactured for the dual purpose of ground fault protection and fiber optic capabilities), pipetype cable installation and maintenance jobs or projects, and maintenance bonding of rails; Pipetype cable installation		
Cable Splicer.....	\$ 58.71	6.75%+24.15
Flagman.....	\$ 32.02	6.75%+24.15
Groundman Digging Machine Operator.....	\$ 48.03	6.75%+24.15
Groundman Truck Driver (tractor-trailer unit)....	\$ 42.70	6.75%+24.15
Groundman Truck Driver....	\$ 42.70	6.75%+24.15
Lineman & Technician.....	\$ 53.37	6.75%+24.15
Mechanic.....	\$ 42.70	6.75%+24.15

FOOTNOTE:

- a. PAID HOLIDAYS: New Year's Day, Presidents' Day, Memorial Day, Good Friday, Independence Day, Labor Day, Thanksgiving

Day, Christmas Day, and Election Day for the President of the United States and Election Day for the Governor of New York State, provided the employee works two days before or two days after the holiday.

 ELEC1249-008 01/01/2019

	Rates	Fringes
ELECTRICIAN (Line Construction)		
TELEPHONE, CATV FIBEROPTICS CABLE AND EQUIPMENT		
Cable splicer.....	\$ 32.78	3%+4.93
Groundman.....	\$ 16.49	3%+4.93
Installer Repairman-Teledata Lineman/Technician-Equipment Operator.....	\$ 31.12	3%+4.93
Tree Trimmer.....	\$ 25.79	3%+9.98+a

a. New Year's Day, President's Day, Good Friday, Decoration Day, Independence Day, Labor Day, Veteran's Day, Thanksgiving Day, Day after Thanksgiving, Christmas Day.

 ELEV0014-001 01/01/2019

	Rates	Fringes
ELEVATOR MECHANIC.....	\$ 49.81	33.705+a+b

FOOTNOTE:

- a. Vacation: 6%/under 5 years based on regular hourly rate for all hours worked. 8%/over 5 years based on regular hourly rate for all hours worked.
- b. PAID HOLIDAYS: New Year's Day; Memorial Day; Independence Day; Labor Day; Veterans' Day; Thanksgiving Day; the Friday after Thanksgiving Day; and Christmas Day.

 ENGI0017-012 07/01/2018

	Rates	Fringes
Power equipment operators:		
GROUP 1.....	\$ 38.73	29.84+a
GROUP 2.....	\$ 34.23	29.84+a
GROUP 3.....	\$ 39.48	29.84+a
GROUP 4.....	\$ 39.73	29.84+a
GROUP 5.....	\$ 40.23	29.84+a
GROUP 6.....	\$ 39.80	29.84+a

NOTE: HAZARDOUS WASTE PREMIUM \$2.50
TUNNEL WORK \$1.00

FOOTNOTES:

a. PAID HOLIDAYS: A-New Year's Day; B-Memorial Day;
C-Independence Day; D-Labor Day; Thanksgiving Day;
F-Christmas Day, provided the employee has worked the day
before and the day after the holiday.

POWER EQUIPMENT OPERATORS CLASSIFICATIONS

GROUP 1: Air hoist, all boom type equipment (100 ft. or less), all pan and carry-alls, archer hoist, asphalt roller asphalt spreader or paver, automatic fine grade machine (CMI and similar type), archer hoist, backhoe and pull hoe (tractor mounted and rubber mounted), back filling machine, belt place (CMI and similar), bending machine (pipe), bituminous spreader and mixer, black top plant (automated), black top plant (non-automated), blast or rotary drill (truck or track mounted), blower for burning brush, boiler (when used for power), boom trucks, boring machine, bulldozer, cableway cage hoist, caisson auger, central mix plant (and all concrete batching plants), cherry picker (over 5 tons), cherry picker (under 5 tons), chipping machine and chip spreader, concrete curb and gutter machines, concrete curing machine, concrete mixer (over 1/2 cu. yd.) concrete pavement spreaders and finishers, concrete paver, concrete pump, concrete saw (self-propelled), conveyor, core drill, crane, crusher, derrick operator, dragline, dredge, drill rig (tractor mounted), dual drum paver, electric pump used in conjunction with well point systems, elevating grader self-propelled or towed), elevator excavator (all purpose, hydraulically operated) farm tractor with accessories, fine

grade machine, forklift, front end loader, generator (10 outlets or more), gradall, grader, grout or gunite machine, head tower, hoist-one drum, hoisting engine, hydraulic boom, hydraulic hammer, (self propelled), hydraulic pipe jack machine (or similar type machine), hydraulic system pumps, hydro crane, hydro hammer (or similar type), industrial tractor, jersey spreader, kolman plant loader (and similar type loaders), locomotive, lubrication truck, maintenance engineer, maintenance lubrication unit or truck, mine hoist, mixer for stabilized base (self-propelled), monorail, motorized hydraulic pin puller, motorized hydraulic seeder mucking machine, mulching machine, multiple drum hoist (more than 1 drum in use), overhead crane, peine crane (or similar type), pile driver, plant engineer, pneumatic mixer, post hole digger, power boom, pumpcrete, push or snatch cat, quarry master or equivalent road widener, rock bit sharpener (all types), roller (all), rolling machine (pipe), rotomill, scoopmobile, shovel, side boom, skimmer, slip form paver (CMI and similar type, first and second operator), snorkel, strato-tower, stump chipping machine, tire truck and repair, towed roller, tractor drawn belt type grader/loader, tractor shovel, tractor with towed accessories, tractors (when using winch power), tractors, trencher, truck crane, tunnel shovel, tube finisher (CMI and similar type), vibratory compactor, vibro tamp, well drilling machine, well point, winch, winch truck with "A" frame.

GROUP 2: Aggregate bin, CMI and similar type concrete spreads, cement bin, chipping machine and chip spreader, compressors (4 or less), compressors: (any size, but subject to other provisions for compressors, dust collectors, generators, mechanical heaters, pumps, welding machines (four of any type or combination), concrete mixer (1/2 cu. yd. and under), fireman, form tamper, fuel truck, heating boiler (used for temporary heat), jeep trencher, power heaterman, power plant in excess of 10 K.W., pump (4" or over), reviniis widener, stem cleaner, stump chipping machine, welding machine (1 machine over 300 amps or 2 or 3 machines regardless of amps).

GROUP 3: Crane with boom over 100 feet

GROUP 4: Crane with boom over 200 feet

GROUP 5: Crane with boom over 300 feet

GROUP 6: Master mechanic

IRON0006-003 07/01/2019

ERIE COUNTY (Excluding Grand Island Township), CATTARAUGUS AND
CHAUTAUQUA

	Rates	Fringes
Ironworker		
Fence Erectors.....	\$ 29.67	26.01
Structural, Ornamental, Reinforcing Steel,		
Welders, Riggers and Rodman.	\$ 31.10	27.51
Window Erectors.....	\$ 28.75	27.51

IRON0006-015 07/01/2019

ERIE (Township of Grand Island)

	Rates	Fringes
IRONWORKER		
Ironworker.....	\$ 31.10	27.51
Sheeter.....	\$ 31.10	27.51

LAB00210-003 07/01/2017

	Rates	Fringes
LABORER		
ERIE COUNTY HEAVY & HIGHWAY		
GROUP 1.....	\$ 29.61	24.35
GROUP 2.....	\$ 29.81	24.35
GROUP 3.....	\$ 30.01	24.35
GROUP 4.....	\$ 30.21	24.35
ERIE COUNTY SEWER/WATER		
GROUP 1.....	\$ 29.61	24.35
GROUP 2.....	\$ 29.71	24.35
GROUP 3.....	\$ 29.76	24.35

GROUP 4.....	\$ 29.86	24.35
GROUP 5.....	\$ 30.21	24.35
GROUP 6.....	\$ 30.61	24.35
ERIE COUNTY TUNNEL		
GROUP 1.....	\$ 31.11	24.35
GROUP 2.....	\$ 31.26	24.35
GROUP 3.....	\$ 31.36	24.35
GROUP 4.....	\$ 31.86	24.35
GROUP 5.....	\$ 31.96	24.35
GROUP 6.....	\$ 32.36	24.35
GROUP 7.....	\$ 32.61	24.35

HEAVY & HIGHWAY CLASSIFICATIONS

GROUP 1: Laborers; flagmen; outboard and hand boats; demolition worker; IBC barriers (except on structures); guard rails; road markers

GROUP 2: Bull float; chain saw; concrete aggregate bin; concrete bootman; gin buggy; hand or machine vibrator; jackhammer; mason tender mortar mixer; pavement breaker; handlers of all steel mesh; small generators for laborers' tools; installation of bridge drainage pipe; pipelayers; vibrator type rollers; tamper; drill doctor; tail or screw operator on asphalt paver; water pump (2" and single diaphragm); nozzle (asphalt, gunnite, seeding and sandblasting); laborers on chain link fence erection; rock splitter and power unit; pusher type concrete saw and all other gas, electric, oil and air tool operators; wrecking laborers; laser man

GROUP 3: All rock or drilling machine operators (except quarry master and similar type); acetylene torch operator; asphalt raker; powderman; welder

GROUP 4: Blasters; curb & flat work form setters (except on structures); stone or granite curb setters

SEWER/WATER CLASSIFICATIONS

GROUP 1: General; flagman; top man; wreckers

GROUP 2: Foundation; rod carriers; plaster tender; scaffold bootman; pneumatic, gas, electric tool operator;

jackhammer; chipping guns

GROUP 3: Mortar mixer over 8 feet in depth

GROUP 4: Pavement formsetter; steelburner; caisson; wagon
drill operator; pipelayer; swing scaffold

GROUP 5: Utility pave driver; laser operator

GROUP 6: Blaster

TUNNEL CLASSIFICATIONS

GROUP 1: Mole nipper; powder handler; top laborer

GROUP 2: Air spade; jackhammer; pavement breaker

GROUP 3: Top bell

GROUP 4: Bottom bell; side or roofbelt driller; burners;
trackmen; nippers; derailmen; hosemen; groutmen; gravelmen;
form workers; movers & shaftmen; conveyormen

GROUP 5: Powder monkey

GROUP 6: Blasters; ironmen; welder; heading driller

GROUP 7: Piledriver; rigger

FOR HEAVY/HIGHWAY & TUNNEL: Additional \$1.00 added to base
rate for all deleader & asbestos work. Additional \$2.00
added to base rate for all hazardous waste work.

LAB00621-001 07/01/2019

CATTARAUGUS COUNTY and Twnships of French Creek, Clymer,
Harmony, Busti, Kiantone, Carroll, Mina, Sherman, Ellicott,
Poland, Jamestown, North Harmony, Gerry, Chautauqua, Ellington,
Ellery, and Stockton in CHAUTAUQUA COUNTY

Rates

Fringes

Laborers:

HEAVY AND HIGHWAY

(ZONE I)

GROUP 1.....	\$ 27.84	21.85
GROUP 2.....	\$ 28.24	21.85

LABORER CLASSIFICATIONS (HEAVY & HIGHWAY)

GROUP 1: Flagman; outboard and hand boats; Bull float; Chain Saw; Concrete aggregate bin; Concrete boot; Gin Buggy; Hand or machine vibrator jack hammer; Mason tender; Mortar mixer; pavement breaker; Handler of all steel mesh; Small generator for laborer tools, installation of bridge drainage pipe; Pipe layers; Vibrator type rollers; Tamper drill doctor; Water pump operator (1-1/2" and single diaphragm); Nozzle (asphalt, gunite, seeding and sandblasting); Laborers on chain link fence erection; rock splitter and power unit; Pusher type concrete saw and all other gas, electric, oil and air tool operators; wrecking laborers.

GROUP 2: Blasters; Form setter; stone or granite curb setters; Designated asphalt rakers (not to include cold patch); tail or screw operator on asphalt paver. All rock or drilling machine operators (except quarry master and similar type); acetylene torch operators; powdermen.

LAB00621-002 07/01/2019

CHAUTAUQUA COUNTY (Townships of Ripley, Westfield, Portland, Pomfret, Dunkirk, Sheridan, Hanover, Villenova, Arkwright, Cherry Creek and Charlotte)

Rates Fringes

Laborers:

CATTARAUGUS COUNTY AND
CHAUTAUQUA COUNTY
(Remaining Townships)
HEAVY AND HIGHWAY

GROUP 1.....	\$ 27.84	21.85
--------------	----------	-------

GROUP 2.....	\$ 28.24	21.85
CHAUTAQUA COUNTY		
(Townships of Ripley, Westfield, Portland, Pomfret, Dunkirk, Sheridan, Hanover, Villanova, Arkwright, Cherry Creek and Charlotte) HEAVY AND HIGHWAY CONSTRUCTION		
GROUP 1.....	\$ 28.79	21.85
GROUP 2.....	\$ 29.19	21.85

For HEAVY & HIGHWAY CLASSIFICATIONS

GROUP 1: Flagmen, Outboard and Hand Boats, Demolition Worker, Nurseryman, IBC Barriers except on Structures, Guard Rail and Road Markers, Bull Float, Chain Saw, Concrete Aggregate Bin, Concrete Bootman, Gin Buggy, Hand or Machine Vibrator, Jack Hammer, Mason Tender, Mortar Mixer, Pavement Breaker, Handlers of All Steel Mesh, Small Generators for Laborers' tools, Installation of Bridge Drainage Pipe, Pipe Layers, Vibrator Type Rollers, Tamper, Drill Doctor, Tail or Screw Operator on Asphalt Paver, Waterpump Operators (1 1/2" and single diaphragm), Nozzle (asphalt gunite, seeding and sand blasting), Laborers on Chain Link Fence Erection, Rock Splitter and Power Unit, Pusher Type Concrete Saw and all other gas, electric, oil and air tool operators, Wrecking Laborer, Laser Man.

GROUP 2: All Rock or Drilling Machine Operators (except quarry master and similar type), Acetylene Torch Operators and Asphalt Raker, Powderman, Blaster, Curb and Flat Work Form Setter not on structures, Stone or Granite curb setters, Stone Cutter.

For HEAVY & HIGHWAY CLASSIFICATIONS in CHAUTAQUA COUNTY
(Remaining Townships)

GROUP 1: Flagman, Outboard and hand boats, Bull float, Chain Saw, Concrete aggregate bin, Concrete boot, Gin buggy, Hand or machine vibrator jack hammer, Mason tender, Mortar mixer, pavement breaker, handler of all steel mesh, Small generator for laborers' tools, installation of bridge

drainage pipe; Pipe layers, Vibrator type rollers, Tamper drill doctor, Water pump operator (1 1/2" and single diaphragm), Nozzle (asphalt, gunite, seeding and sandblasting) Laborers on chain link fence erection, rock splitter and power unit, Pusher type concrete saw and all other gas, electric, oil and air tool operators, wrecking laborers.

GROUP 2: Blasters, Form setters, stone or granite curb setters; Designated asphalt rakers (not to include cold patch), tail or screw operator on asphalt paver. All rock or drilling machine operators (except quarry master and similar type), acetylene torch operators, powderman.

 PAIN004-001 05/01/2019

CHAUTAUQUA COUNTY (Townships of Awkwright, Dunkirk, Hanover, Pomfret, Portland, Sheridan, Villenova); CATTARAUGUS COUNTY (Townships of Ashford, Dayton, East Otto, Machias, Otto, Perrysburg, Persia, Yorkshire); ERIE COUNTY (Entire county, excluding area North of Whitehaven Road, Grand Island)

	Rates	Fringes
Painters: (BUILDING CONSTRUCTION)		
ERIE COUNTY		
BRUSH AND ROLLER.....	\$ 26.45	24.94
DRYWALL/TAPING.....	\$ 26.95	24.94
WALLCOVERING.....	\$ 26.45	24.94
Painters: (HEAVY & HIGHWAY CONSTRUCTION)		
CATTARAUGUS, CHAUTAUQUA & ERIE COUNTIES.....	\$ 38.50	28.40

 PAIN004-004 05/01/2019

ERIE COUNTY, (AREA NORTH OF WHITEHAVEN ROAD, GRAND ISLAND, NEW YORK)

	Rates	Fringes
--	-------	---------

Painters:

BUILDING CONSTRUCTION

Lead Abatement.....	\$ 25.43	19.51
Painters.....	\$ 24.68	19.51
Spraying, Paperhangers, Sand-Blasting, Swinging scaffold.....	\$ 24.93	19.51
Tapers.....	\$ 25.18	19.51

HEAVY & HIGHWAY
CONSTRUCTION

Bridge Painter.....	\$ 38.50	28.40
---------------------	----------	-------

PAIN0004-007 05/01/2019

Rates Fringes

GLAZIER.....	\$ 27.12	22.25
--------------	----------	-------

PAIN0004-008 05/01/2019

CATTARAUGUS COUNTY - Townships of Leon, Conewango, Randolph,
South Valley, Napoli and New Albion;

CHAUTAUQUA COUNTY - Townships of French Creek, Mina, Ripley,
Westfield, Sherman, Clymer, Chautauqua, North Harmony, Harmony,
Busti, Ellery, Stockton, Charlotte, Gerry, Ellicott, Jamestown,
Kiantone, Carroll, Poland, Ellington and Cherry Creek.

Rates Fringes

Painters: (HEAVY & HIGHWAY
CONSTRUCTION)

Bridges.....	\$ 38.50	28.40
--------------	----------	-------

PAIN0004-017 05/01/2019

CATTARAUGUS COUNTY (Townships of Cold Spring, Elko, Mansfield,
Little Valley, Salamanca Indian Reservation, Red House,
Ellicottville, Great Valley, Carrolton, Franklinville,
Humphrey, Allegany, Freedom, Farmersville, Lyndon, Ishua,
Hinsdale, Olean and Portville)

Rates Fringes

Painters: (HEAVY & HIGHWAY
CONSTRUCTION)

Bridges.....	\$ 38.50	28.40
--------------	----------	-------

PLAS0009-001 04/01/2019

	Rates	Fringes
--	-------	---------

PLASTERER.....	\$ 30.15	20.49
----------------	----------	-------

PLAS0111-001 07/01/2018

	Rates	Fringes
--	-------	---------

CEMENT FINISHER.....	\$ 30.00	30.62
----------------------	----------	-------

PLUM0022-001 04/29/2019

CATTARAUGUS- Townships of Perryburg, Dayton, Persia, Otto,
Leon, and New Albion;

CHATAUQUA- Townships of Hanover, Sheridan, Dunkirk, Pomfret,
Arkwright, Villanova, Portland, Stockton, Charlotte, Ripley and
Westfield;

ERIE- All Townships in the County.

	Rates	Fringes
--	-------	---------

PLUMBER/PIPEFITTER

ZONE 1.....	\$ 36.45	25.75
-------------	----------	-------

Steamfitter

ZONE 1.....	\$ 36.45	25.75
-------------	----------	-------

PLUM0022-004 04/29/2019

ZONE 2

CATTARAUGUS- Townships of Conewango, Napoli, East Otto,
Mansfield, Little Valley, Randolph, South Valley, Colesprings,
Salemanca, Ashford, Ellicottville, Great Valley, Carrollton,
Yorkshire, Freedom, Farmersville Station, Machias, Lyndon,
Franklinville, Humphrey, Ischua, Allegany, Hinsdale, Olean,
Portville;

ZONE 1

CHAUTAUQUA - Townships of Cherry Creek, Ellington, Polland, Carroll, Gerry, Ellicott, Kiantone, Ellery, Busti, Harmony, North Harmony, Chautauqua, Sherman, Mina, French Creek, Clymer.

	Rates	Fringes
PLUMBER/PIPEFITTER		
ZONE 1.....	\$ 36.45	25.75
ZONE 2.....	\$ 34.88	25.75

ROOF0074-001 06/01/2019

ERIE COUNTY

	Rates	Fringes
Roofers:		
Composition.....	\$ 29.00	22.39
Slate & Tile.....	\$ 29.15	22.39

ROOF0210-005 06/01/2010

	Rates	Fringes
ROOFER.....	\$ 23.65	11.99

SFNY0669-001 04/01/2019

	Rates	Fringes
SPRINKLER FITTER.....	\$ 36.70	24.94

* SHEE0071-001 05/27/2019

ERIE COUNTY:

	Rates	Fringes
Sheet metal worker.....	\$ 34.38	25.04

SHEE0112-001 07/01/2016

CATTARAUGUS AND CHAUTAUQUA COUNTIES:

	Rates	Fringes
SHEET METAL WORKER.....	\$ 26.48	22.22

 TEAM0264-001 04/01/2019

CATTARAUGUS AND CHAUTAUQUA COUNTIES

	Rates	Fringes
Truck drivers:		
GROUP 1.....	\$ 38.31	14.78+a
GROUP 2.....	\$ 38.31	14.78+a

FOOTNOTE:

- a. PAID HOLIDAYS: Memorial Day, Independence Day, Labor Day, Thanksgiving Day and Christmas Day, provided employee has worked the day before and the day after the holiday.

TRUCK DRIVER CLASSIFICATIONS

GROUP 1: Pickups, panel trucks, flatboy material trucks (straight jobs), single-axle dump trucks, dumpsters, Tandems, batch trucks, mechanics semi trailers, low-boy trucks, asphalt distributor trucks, agitator, mixer trucks and dumpcrete type vehicles, truck mechanics, fuel trucks.

GROUP 2: Specialized earth moving equipment-euclid type or similar off-highway equipment, where not self-loaded, straddle (ross) carrier, self-contained concrete unit, off-highway tandem back-dump, twin engine equipent and double-hitched equipment where not self-loaded.

 TEAM0449-002 07/01/2018

ERIE COUNTY

	Rates	Fringes
Truck drivers: (Includes Single Axle Dump and Off-Highway Dump Trucks).....	\$ 38.15	5.00+a+b

Work on a hazardous waste site then additional \$2.00 per hour.

FOOTNOTE: a. Pension \$56.20 per day

b. Paid Holidays: New Years Day, Memorial Day, Independence Day, Labor Day, Thanksgiving Day, Christmas Day provided the employee has worked the working day before and after the holiday

TEAM0449-005 06/01/2018

ERIE COUNTY

	Rates	Fringes
Truck drivers: (Dump Truck Only, Excludes Single Axle Dump and Off-Highway Dump Trucks).....	\$ 21.25	3.46+a

FOOTNOTE: a. Paid Holidays: New Years Day, Memorial Day, Independence Day, Labor Day, Thanksgiving Day, Christmas Day provided the employee has worked the working day before and after the holiday

WELDERS - Receive rate prescribed for craft performing operation to which welding is incidental.

=====

Note: Executive Order (EO) 13706, Establishing Paid Sick Leave for Federal Contractors applies to all contracts subject to the Davis-Bacon Act for which the contract is awarded (and any solicitation was issued) on or after January 1, 2017. If this contract is covered by the EO, the contractor must provide employees with 1 hour of paid sick leave for every 30 hours they work, up to 56 hours of paid sick leave each year. Employees must be permitted to use paid sick leave for their own illness, injury or other health-related needs, including preventive care; to assist a family member (or person who is

like family to the employee) who is ill, injured, or has other health-related needs, including preventive care; or for reasons resulting from, or to assist a family member (or person who is like family to the employee) who is a victim of, domestic violence, sexual assault, or stalking. Additional information on contractor requirements and worker protections under the EO is available at www.dol.gov/whd/govcontracts.

Unlisted classifications needed for work not included within the scope of the classifications listed may be added after award only as provided in the labor standards contract clauses (29CFR 5.5 (a) (1) (ii)).

The body of each wage determination lists the classification and wage rates that have been found to be prevailing for the cited type(s) of construction in the area covered by the wage determination. The classifications are listed in alphabetical order of ""identifiers"" that indicate whether the particular rate is a union rate (current union negotiated rate for local), a survey rate (weighted average rate) or a union average rate (weighted union average rate).

Union Rate Identifiers

A four letter classification abbreviation identifier enclosed in dotted lines beginning with characters other than ""SU"" or ""UAVG"" denotes that the union classification and rate were prevailing for that classification in the survey. Example: PLUM0198-005 07/01/2014. PLUM is an abbreviation identifier of the union which prevailed in the survey for this classification, which in this example would be Plumbers. 0198 indicates the local union number or district council number where applicable, i.e., Plumbers Local 0198. The next number, 005 in the example, is an internal number used in processing the wage determination. 07/01/2014 is the effective date of the most current negotiated rate, which in this example is July 1, 2014.

Union prevailing wage rates are updated to reflect all rate changes in the collective bargaining agreement (CBA) governing this classification and rate.

Survey Rate Identifiers

Classifications listed under the "SU" identifier indicate that no one rate prevailed for this classification in the survey and the published rate is derived by computing a weighted average rate based on all the rates reported in the survey for that classification. As this weighted average rate includes all rates reported in the survey, it may include both union and non-union rates. Example: SULA2012-007 5/13/2014. SU indicates the rates are survey rates based on a weighted average calculation of rates and are not majority rates. LA indicates the State of Louisiana. 2012 is the year of survey on which these classifications and rates are based. The next number, 007 in the example, is an internal number used in producing the wage determination. 5/13/2014 indicates the survey completion date for the classifications and rates under that identifier.

Survey wage rates are not updated and remain in effect until a new survey is conducted.

Union Average Rate Identifiers

Classification(s) listed under the UAVG identifier indicate that no single majority rate prevailed for those classifications; however, 100% of the data reported for the classifications was union data. EXAMPLE: UAVG-OH-0010 08/29/2014. UAVG indicates that the rate is a weighted union average rate. OH indicates the state. The next number, 0010 in the example, is an internal number used in producing the wage determination. 08/29/2014 indicates the survey completion date for the classifications and rates under that identifier.

A UAVG rate will be updated once a year, usually in January of each year, to reflect a weighted average of the current negotiated/CBA rate of the union locals from which the rate is based.

WAGE DETERMINATION APPEALS PROCESS

1.) Has there been an initial decision in the matter? This can

be:

- * an existing published wage determination
- * a survey underlying a wage determination
- * a Wage and Hour Division letter setting forth a position on a wage determination matter
- * a conformance (additional classification and rate) ruling

On survey related matters, initial contact, including requests for summaries of surveys, should be with the Wage and Hour Regional Office for the area in which the survey was conducted because those Regional Offices have responsibility for the Davis-Bacon survey program. If the response from this initial contact is not satisfactory, then the process described in 2.) and 3.) should be followed.

With regard to any other matter not yet ripe for the formal process described here, initial contact should be with the Branch of Construction Wage Determinations. Write to:

Branch of Construction Wage Determinations
Wage and Hour Division
U.S. Department of Labor
200 Constitution Avenue, N.W.
Washington, DC 20210

2.) If the answer to the question in 1.) is yes, then an interested party (those affected by the action) can request review and reconsideration from the Wage and Hour Administrator (See 29 CFR Part 1.8 and 29 CFR Part 7). Write to:

Wage and Hour Administrator
U.S. Department of Labor
200 Constitution Avenue, N.W.
Washington, DC 20210

The request should be accompanied by a full statement of the interested party's position and by any information (wage payment data, project description, area practice material, etc.) that the requestor considers relevant to the issue.

3.) If the decision of the Administrator is not favorable, an interested party may appeal directly to the Administrative Review Board (formerly the Wage Appeals Board). Write to:

Administrative Review Board
U.S. Department of Labor
200 Constitution Avenue, N.W.
Washington, DC 20210

4.) All decisions by the Administrative Review Board are final.

=====

END OF GENERAL DECISION"

SECTION J

Location Maps, Bridge Structure Information & Existing Conditions Photographs And Analytical Laboratory Results

SUPPLEMENTAL INFORMATION AVAILABLE TO BIDDERS

The following information is available at the Office having jurisdiction for this project, as identified in the advertisement for bids, for inspection and review prior to the letting date. It is mutually understood that this data is independent information the County has assembled and the bidder shall assume the risk of its accuracy and that the information is not prepared or used as part of the contract plans and that Article 3 of the NYSDOT Standard Specifications will apply as to the site conditions. This information is not to be considered as a substitution or revision of that section of the Standard Specifications defining specifications and contract agreements.

By his signature on this proposal the bidder certifies that he has made himself aware of the availability, for his inspection and review prior to the letting date, of the information indicated below:

PIN 5761.98

AVAILABLE	NOT AVAILABLE	INFORMATION
	X	Utility Estimate Sheets with Names of Utility Officials
	X	Right of Way Plan
	X	Earthwork Cross Section Sheets
	X	Earthwork Sheets
	X	Drainage Estimate Sheets
	X	Sign Face Layouts
	X	Logs of Subsurface Exploration
	X	Tabulated Results of Probing
	X	Tabulated Depth to Bed Rock
	X	Logs Showing Laboratory Description of Soil Samples
	X	Laboratory Test Data from Soil Samples
	X	Rock Outcrop Maps
	X	Granular Materials Resources Survey Reports
	X	Terrain Reconnaissance Reports
	X	Subsurface Data Obtained from Sources Outside the Department
	X	Rock Cores (available for inspection)
	X	Record Plans
X		Special Reports or Other Information (Identify Below & Attached) <ul style="list-style-type: none"> ➤ Supplemental Information Available to Bidder ➤ Location Maps & Structure Data Sheets ➤ Lead Testing Results

FREEDOM BRIDGE NO. 1

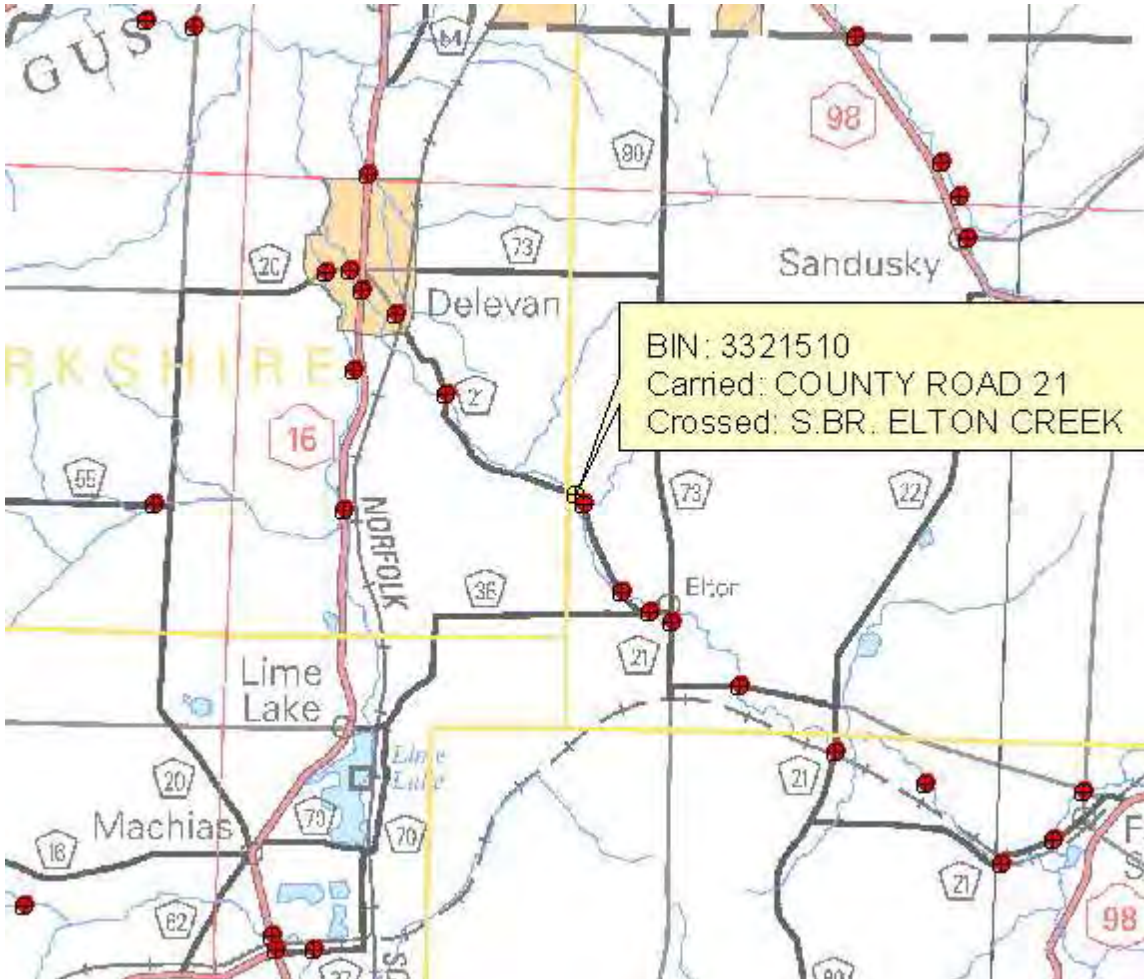

Cattaraugus County, 2020 Bridge Painting Candidates

FREEDOM BRIDGE NO. 1

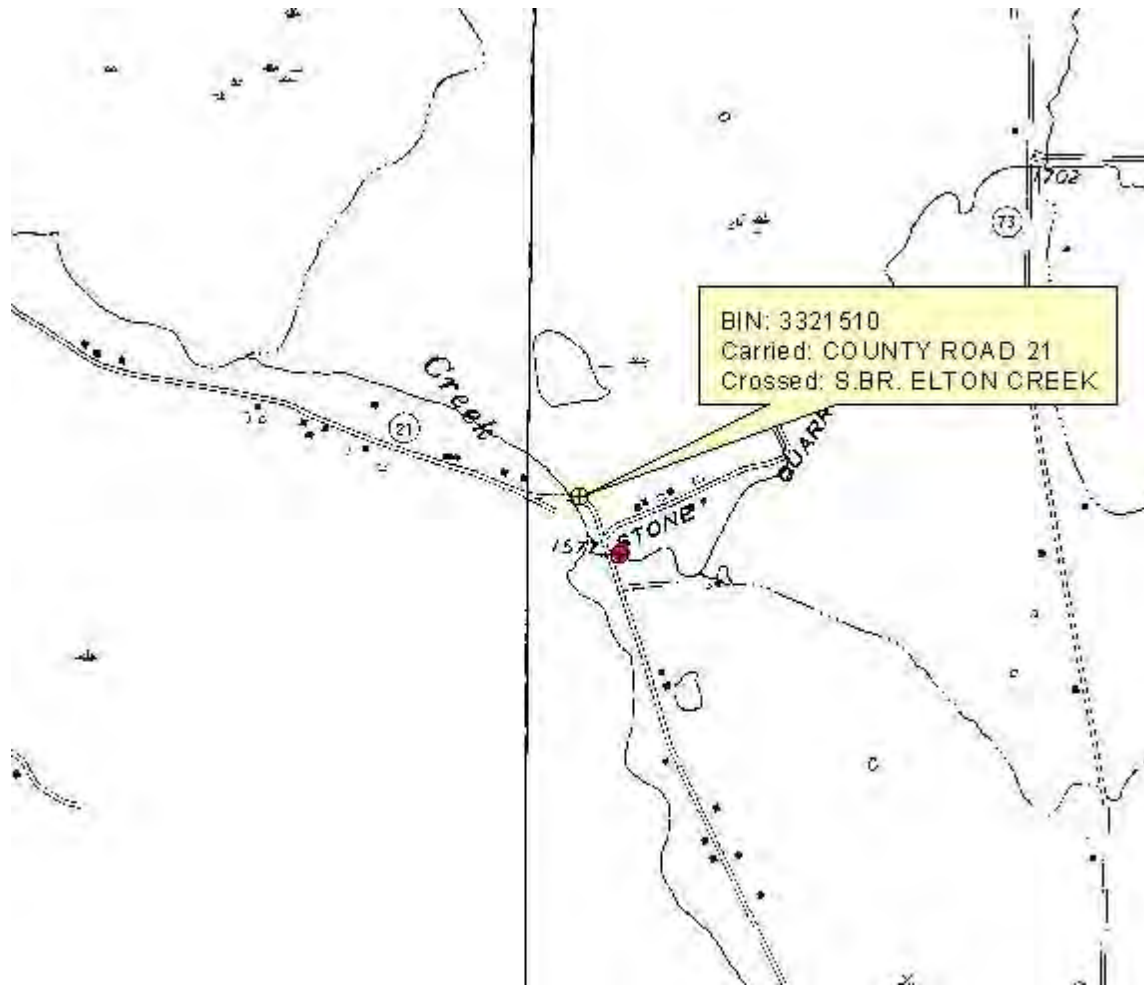

Freedom Bridge No. 1, CR 21 Delevan-Elton Road over South Branch Elton Creek
(BIN 3320970)



Cattaraugus County Bridge and Culvert Structure Information

BIN: 3321510
Name: Freedom Bridge No. 1
Inspection Agency: 13 - Consultant
Type of Inspection: 1 - BIENNIAL
GTMS: 03 -- Steel – stringer/multi-beam or girder
POSTINGS: No Posting
Further Investigation Needed: None
State Highway Number: N/A
Mile point: N/A
AADT/Yr: Not Available
Orientation: 8 - Northwest
Political Unit: Town of Freedom
Year Built: 1973
Total Spans: 1
Ramp Bridge Attached To Span: NA
General Recommendation: 6

FREEDOM BRIDGE NO. 1



FREEDOM BRIDGE NO. 1



EAST OTTO BRIDGE NO. 27

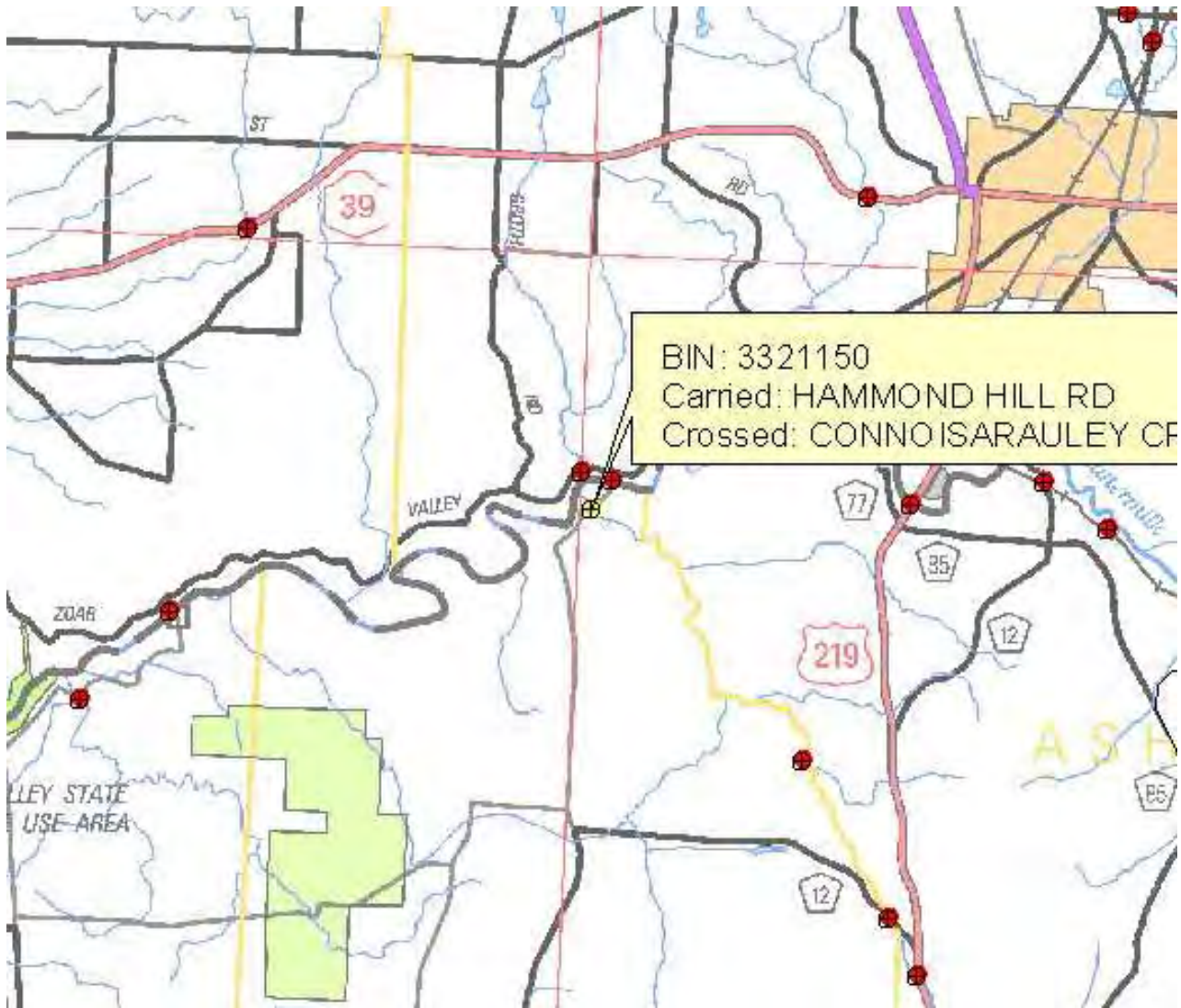

Cattaraugus County, 2020 Bridge Painting Candidates

EAST OTTO BRIDGE NO. 27

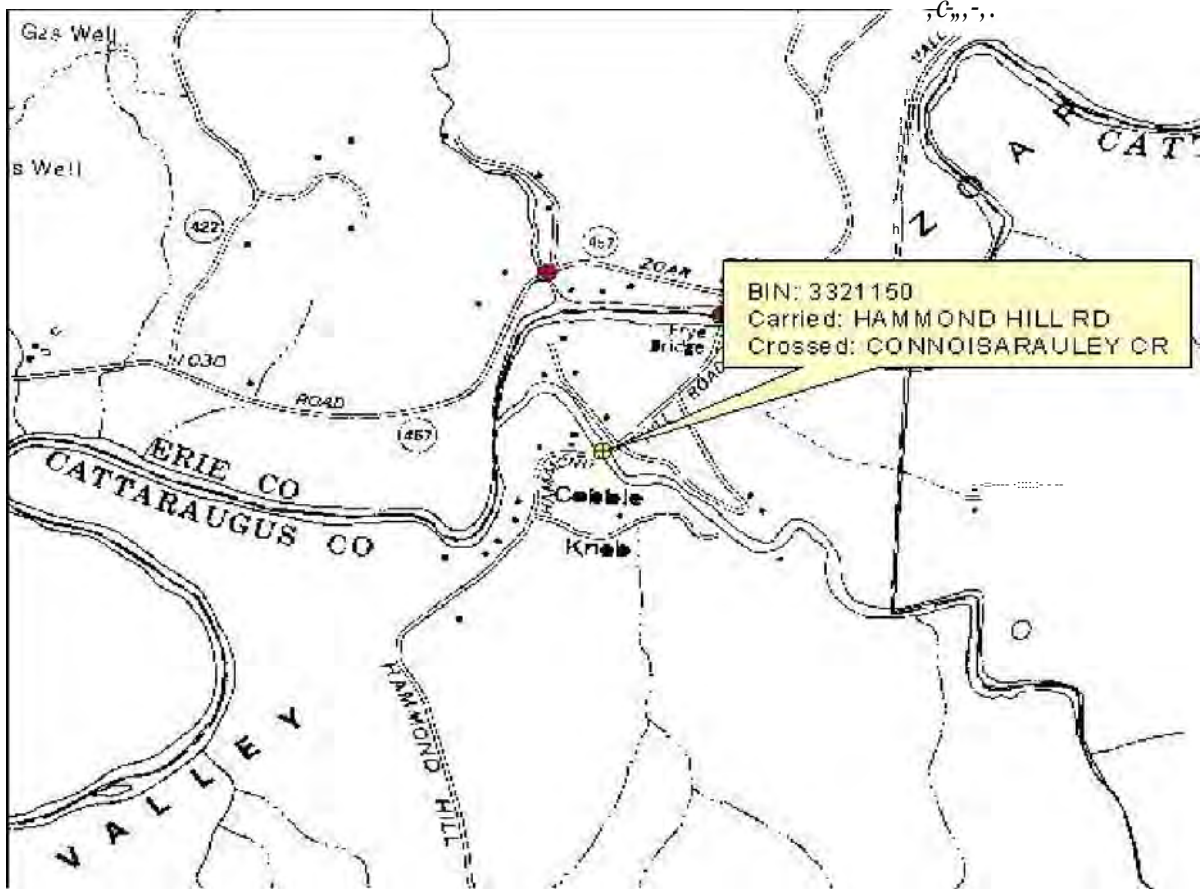

East Otto Bridge No 27, Hammond Hill Road over Connoisarauley Creek (BIN 3321150)



Cattaraugus County Bridge and Culvert Structure Information

BIN: 3321150
Name: East Otto Bridge No. 27
Inspection Agency: 13 - Consultant
Type of Inspection: 1 - BIENNIAL
GTMS: 03 -- Steel – Girder and Floor beam System
POSTINGS: No Posting
Further Investigation Needed: No
State Highway Number: N/A
Mile point: N/A
AADT/Yr: Not Available
Orientation: 2 - northeast
Political Unit: Town of East Otto
Year Built: 1972
Total Spans: 1
Ramp Bridge Attached To Span: NA
General Recommendation: 5

EAST OTTO BRIDGE NO. 27



EAST OTTO BRIDGE NO. 27



SOUTH VALLEY BRIDGE NO. 4

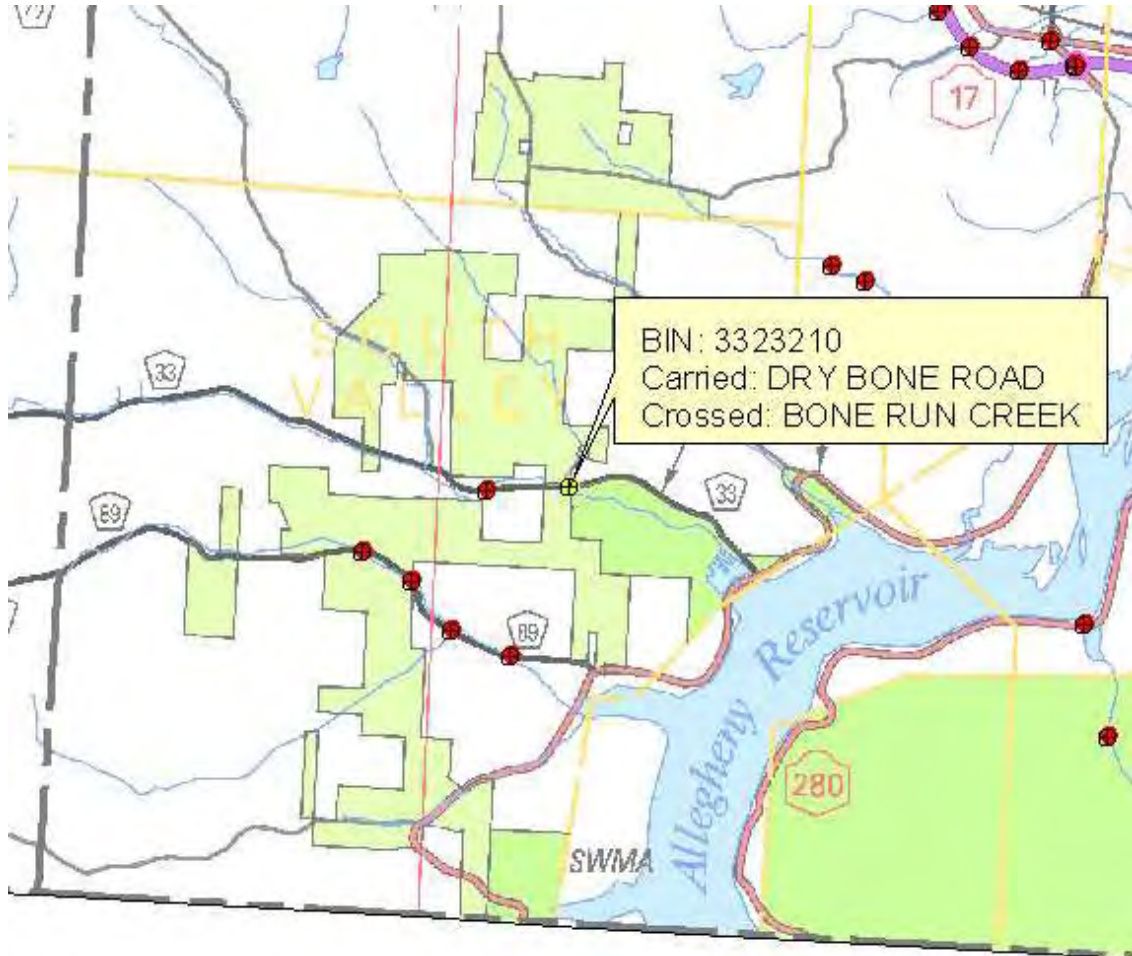

Cattaraugus County, 2020 Bridge Painting Candidates

SOUTH VALLEY BRIDGE NO. 4



South Valley Bridge No. 4, County Road 33 over Bone Run (BIN 3323210)



Cattaraugus County Bridge and Culvert Structure Information

BIN: 3323210
Name: South Valley Bridge No.4
Inspection Agency: 13 - Consultant
Type of Inspection: 1 - BIENNIAL
GTMS: 03 -- Steel --Stringer/Multi-Beam or Girder
POSTINGS: No Posting
Further Investigation Needed: No
State Highway Number: N/A
Milepoint: N/A
AADT/Yr: N/A
Orientation: 3 – East
Political Unit: Town of South Valley
Year Built: 1982
Total Spans: 1
Ramp Bridge Attached To Span: NA
General Recommendation: 6

SOUTH VALLEY BRIDGE NO. 4



SOUTH VALLEY BRIDGE NO. 4



ANALYTICAL LABORATORY REPORT

Wednesday, March 6, 2019

Page 1 of 6

CUSTOMER: Greenman-Pedersen, Inc.
4950 Genesee St. Suite 165
Buffalo, New York 14225

DATE RECEIVED: Friday, March 1, 2019
PO/PROJECT #: BUF-2019009.00
SUBMITTAL #: 2019-03-01-004

LAB NUMBER: AC74503

Sampled By: Scott W. Schmelzinger
Job Location: Cattaraugus County
Sample Identification: 1: South Valley Bridge No. 4 (Beam)

Date Sampled: February 20, 2019
Sample Description: Paint Chips

Preparation Method: EPA 3050B-P-M (Acid Digestion for Paints)
Analysis Method: EPA 6010C-M (ICP-AES Method for Determination of Metals)
Date Analyzed: Monday, March 4, 2019

ELEMENT	RESULT (by dry weight)	REPORTING LIMIT (RL)
Cadmium	< RL	0.00075 %
Chromium	0.0016 %	0.0013 %
Lead	< RL	0.0025 %

LAB NUMBER: AC74504

Sampled By: Scott W. Schmelzinger
Job Location: Cattaraugus County
Sample Identification: 2: South Valley Bridge No. 4 (Wing Wall)

Date Sampled: February 20, 2019
Sample Description: Paint Chips

Preparation Method: EPA 3050B-P-M (Acid Digestion for Paints)
Analysis Method: EPA 6010C-M (ICP-AES Method for Determination of Metals)
Date Analyzed: Monday, March 4, 2019

ELEMENT	RESULT (by dry weight)	REPORTING LIMIT (RL)
Cadmium	< RL	0.00075 %
Chromium	0.0050 %	0.0013 %
Lead	0.0035 %	0.0025 %

ANALYTICAL LABORATORY REPORT

Wednesday, March 6, 2019

Page 4 of 6

CUSTOMER: Greenman-Pedersen, Inc.
4950 Genesee St. Suite 165
Buffalo, New York 14225

DATE RECEIVED: Friday, March 1, 2019
PO/PROJECT #: BUF-2019009.00
SUBMITTAL #: 2019-03-01-004

LAB NUMBER: AC74512

Sampled By: Scott W. Schmelzinger
Job Location: Cattaraugus County
Sample Identification: 10: East Otto Bridge No. 27 (Wing Wall)

Date Sampled: February 21, 2019
Sample Description: Paint Chips

Preparation Method: EPA 3050B-P-M (Acid Digestion for Paints)
Analysis Method: EPA 6010C-M (ICP-AES Method for Determination of Metals)
Date Analyzed: Monday, March 4, 2019

ELEMENT	RESULT (by dry weight)	REPORTING LIMIT (RL)
Cadmium	< RL	0.00075 %
Chromium	0.0074 %	0.0013 %
Lead	< RL	0.0025 %

LAB NUMBER: AC74513

Sampled By: Scott W. Schmelzinger
Job Location: Cattaraugus County
Sample Identification: 11: East Otto Bridge No. 27 (Beam)

Date Sampled: February 21, 2019
Sample Description: Paint Chips

Preparation Method: EPA 3050B-P-M (Acid Digestion for Paints)
Analysis Method: EPA 6010C-M (ICP-AES Method for Determination of Metals)
Date Analyzed: Monday, March 4, 2019

ELEMENT	RESULT (by dry weight)	REPORTING LIMIT (RL)
Cadmium	< RL	0.00075 %
Chromium	0.0066 %	0.0013 %
Lead	< RL	0.0025 %

LAB NUMBER: AC74514

Sampled By: Scott W. Schmelzinger
Job Location: Cattaraugus County
Sample Identification: 12: Freedom Bridge No. 1 (Wing Wall)

Date Sampled: February 21, 2019
Sample Description: Paint Chips

Preparation Method: EPA 3050B-P-M (Acid Digestion for Paints)
Analysis Method: EPA 6010C-M (ICP-AES Method for Determination of Metals)
Date Analyzed: Monday, March 4, 2019

ELEMENT	RESULT (by dry weight)	REPORTING LIMIT (RL)
Cadmium	< RL	0.00075 %
Chromium	< RL	0.0013 %
Lead	< RL	0.0025 %

GPI Laboratories, Inc. has obtained accreditation under the programs detailed on the final page of the laboratory report. The accreditations pertain only to the testing performed for the elements, and in accordance with the test methods, listed in the scope of accreditation table. Testing which is performed by GPI Laboratories, Inc. according to other test methods, or for elements which are not included in the table fall outside of the current scope of laboratory accreditation.

This report shall not be reproduced except in full, without written approval of GPI Laboratories, Inc.

ANALYTICAL LABORATORY REPORT

Wednesday, March 6, 2019

Page 5 of 6

CUSTOMER: Greenman-Pedersen, Inc.
4950 Genesee St. Suite 165
Buffalo, New York 14225

DATE RECEIVED: Friday, March 1, 2019
PO/PROJECT #: BUF-2019009.00
SUBMITTAL #: 2019-03-01-004

LAB NUMBER: AC74515

Sampled By: Scott W. Schmelzinger

Date Sampled: February 21, 2019

Job Location: Cattaraugus County

Sample Description: Paint Chips

Sample Identification: 13: Freedom Bridge No. 1 (Beam)

Preparation Method: EPA 3050B-P-M (Acid Digestion for Paints)

Analysis Method: EPA 6010C-M (ICP-AES Method for Determination of Metals)

Date Analyzed: Monday, March 4, 2019

<u>ELEMENT</u>	<u>RESULT (by dry weight)</u>	<u>REPORTING LIMIT (RL)</u>
Cadmium	< RL	0.00075 %
Chromium	0.0016 %	0.0013 %
Lead	< RL	0.0025 %

GPI Laboratories, Inc. has obtained accreditation under the programs detailed on the final page of the laboratory report. The accreditations pertain only to the testing performed for the elements, and in accordance with the test methods, listed in the scope of accreditation table. Testing which is performed by GPI Laboratories, Inc. according to other test methods, or for elements which are not included in the table fall outside of the current scope of laboratory accreditation.

This report shall not be reproduced except in full, without written approval of GPI Laboratories, Inc..

CATTARAUGUS COUNTY, NEW YORK

2020 Bridge Painting Program CONTRACT DRAWINGS

GPI JOB. NO. 2019030
P.I.N. 5762.92

Cattaraugus County Department of Public Works

KATHLEEN M. ELLIS MARK C. BURR, P.E.
COMMISSIONER DIRECTOR OF ENGINEERING

8810 N.Y.S. RTE. 242,
LITTLE VALLEY, NEW YORK 14755

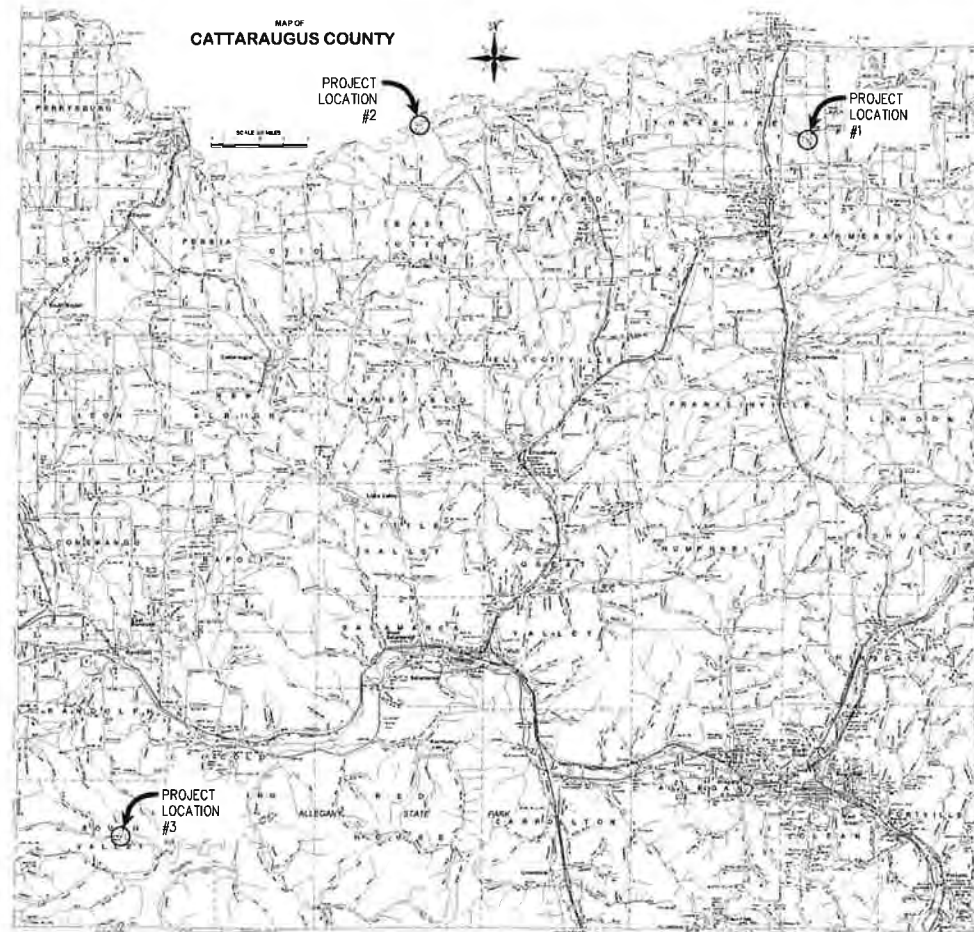

PROJECT LOCATION #1 (B.I.N. 3321510)
FREEDOM BRIDGE NO. 1, DELEVAN-ELTON (C.R. 21) ROAD OVER SOUTH BRANCH ELTON CREEK

PROJECT LOCATION #2 (B.I.N. 3321150)
EAST OTTO BRIDGE NO. 27, HAMMOND HILL ROAD OVER CONNOSARAULEY CREEK

PROJECT LOCATION #3 (B.I.N. 3323210)
SOUTH VALLEY BRIDGE NO.4, COUNTY ROAD OVER BONE RUN

Greenman-Pedersen, Inc.

Consulting Engineers

4950 Genesee Street, Suite 100, Buffalo, New York 14225

403 Main Street, Suite 330, Buffalo, New York 14203

400 Andrews Street, Suite 610, Rochester, New York 14604

200 Harrison Street, Suite H-2, Jamestown, New York 14701

Thomas J. Bender
THOMAS J. BENDER, P.E.

2/21/2020
date

DRAWING INDEX		
SHEET NO.	DRAWING DESCRIPTION	PROJECT LOCATION
COV-1	COVER SHEET	-
GN-1	GENERAL NOTES	-
PL-1	PAINT CONTRACT DRAWING	FREEDOM BRIDGE NO. 1, DELEVAN-ELTON ROAD OVER S. BRANCH ELTON CREEK
PL-2	PAINT CONTRACT DRAWING	EAST OTTO BRIDGE NO. 27, HAMMOND HILL ROAD OVER CONNOSARAULEY CREEK
PL-3	PAINT CONTRACT DRAWING	SOUTH VALLEY BRIDGE NO. 4, COUNTY ROAD 33 OVER BONE RUN
WZTC-1	TRAFFIC CONTROL	-
WZTC-2	TRAFFIC CONTROL	-

Greenman-Pedersen, Inc.
Engineering and Construction Services
Buffalo (716) 633-4844
Rochester (585) 486-4859
Jamestown (716) 488-2803

GPI



SCALE: NONE	DRAWN BY: SID	CHECKED BY: GEB	DATE: AUG 2019	JOB NO.: BUF-2019030.00	BY: _____	DATE: _____
DWG NO.: 1	REVISIONS:		NO.	1		

COVER SHEET
CATTARAUGUS DEPARTMENT OF PUBLIC WORKS
2020 BRIDGE PAINTING PROJECT
VARIOUS LOCATIONS IN CATTARAUGUS COUNTY

SHEET NO.
COV-1

WARNING: A VIOLATION OF THIS REGULATION IS CONSIDERED TO BE A VIOLATION OF SECTION 2209, SUBSECTION 2, STATE ELECTION LAW AND PENALTIES

GENERAL NOTES

1. ON MEMBERS THAT REQUIRE TOTAL PAINT REMOVAL, THE CONTRACTOR SHALL CLEAN THE EXISTING STEEL TO THE LEVEL WHICH MEETS SSPC-SP10 (NEAR - WHITE BLAST CLEANING) REQUIREMENTS.
2. THE ONLY PAINT SYSTEMS APPROVED FOR THIS PROJECT ARE THOSE WHICH ARE ON THE NYSDOT APPROVED LIST FOR SECTION 780-01 STRUCTURAL STEEL PAINTS - CLASS 1.
3. THE CONTRACTOR SHALL PROVIDE THE OWNER WITH A SIGNED PROPERTY RELEASE FROM THE LAND OWNER OF THE STAGING AREA PRIOR TO BEGINNING ANY WORK.
4. THE CONTRACTOR SHALL REMOVE THE EXISTING CORRUGATED BEAM GUIDE RAIL TO CLEAN, PRIME, AND PAINT THE POSTS AND BACKUP CHANNEL. AFTER PAINTING, THE CORRUGATED RAIL SHALL BE REINSTALLED IN PLACE. AT NO TIME SHALL THE STRUCTURE BE OPEN TO TRAFFIC WITHOUT HAVING THE GUIDE RAIL IN PLACE. PAYMENT FOR REMOVAL AND REINSTALLING THE RAIL SHALL BE INCLUDED IN ITEM 573.01 (STRUCTURAL STEEL PAINTING FIELD APPLIED - TOTAL REMOVAL).
5. THE CONTRACTOR SHALL MAINTAIN TRAFFIC ON THE EXISTING STRUCTURE AT ALL TIMES. THE CONTRACTOR SHALL HAVE A SUFFICIENT NUMBER OF FLAGGERS AT EACH SITE TO MAINTAIN TRAFFIC. SEGREGATED WORK AREAS MAY BE REQUIRED TO MAINTAIN TRAFFIC.
6. THE CONTRACTOR SHALL PROTECT THE PUBLIC (TRAFFIC) FROM THE ABRASIVE BLASTING OPERATIONS AT ALL TIMES AND SPECIAL CARE IS TO BE TAKEN WITH THE STRUCTURES HAVING OPEN GRATE STEEL DECKS.
7. THE SOLID WASTE MATERIAL GENERATED BY THE PRESSURE WASHING OPERATION MAY CONTAIN MORE THAN 2% BY WEIGHT OF ORGANIC MATERIAL. THE CONTRACTOR IS ALERTED TO THE NEED TO CAREFULLY INSPECT THE STRUCTURE PRIOR TO BIDDING FOR THE EXISTENCE OF ORGANIC MATTER SUCH AS SAND, PAPER, BIRD NESTS, ANIMAL DROPPINGS, OTHER TRASH AND DEBRIS, AND LOOSE RUST AND PAINT. WHILE TREATMENT AND DISPOSAL OF THIS WASTE IS COVERED UNDER ITEM 571.03 - DISPOSAL OF HAZARDOUS SOLID PAINT WASTE, THE MATERIAL MUST BE STORED IN SEPARATE CONTAINERS FROM THE PAINT WASTE AND MARKED AS "BRIDGE WASHING WASTE" REQUIREMENTS ARE PROVIDED IN SECTION 571 OF THE STANDARD SPECIFICATIONS. AS REVISED IN THIS CONTRACT.
8. THE CONTRACTOR IS RESPONSIBLE FOR REMOVING BRUSH AND ANY OTHER DEBRIS WHICH WOULD IMPEDE PAINTING.
9. THE CONTRACTOR SHALL NOTE WHAT TYPE OF ABRASIVE MEDIA IS ALLOWED FOR EACH OF THE STRUCTURES ON THE TABLE BELOW.
10. STEEL ABUTMENTS ARE TO BE PAINTED TO NEAR WATER LINE AS DETERMINED IN FIELD.

SPECIAL PROCEDURES

1. SURFACE PREPARATION (WITH THE EXCEPTION OF ABUTMENTS/LOCKSHEET PILING). SHALL BE SSPC-SP10 / NACE 2 NEAR - WHITE BLAST CLEANING. WHEN VIEWED WITHOUT MAGNIFICATION SHALL BE FREE OF ALL VISIBLE OIL, GREASE, DUST, DIRT, MILL SCALE, RUST, COATING, OXIDES, CORROSION PRODUCTS AND OTHER FOREIGN MATTER OF AT LEAST 95% OF EACH UNIT AREA. STAINING SHALL BE LIMITED TO NO MORE THAN 5 PERCENT OF EACH UNIT AREA, AND MAY CONSIST OF LIGHT SHADOWS, SLIGHT STREAKS, OR MINOR DISCOLORATIONS CAUSED BY STAINS OF RUST, STAINS OF MILL SCALE, OR STAINS OF PREVIOUSLY APPLIED COATINGS. UNIT AREA SHALL BE APPROXIMATELY 3 IN. X 3 IN. (9 SQ. IN.). SURFACE PREPARATION OF ABUTMENTS/LOCKSHEET PILING (ALL BRIDGES)/NACE 3 NEAR - COMMERCIAL BLAST CLEANING. WHEN VIEWED WITHOUT MAGNIFICATION, THE SURFACE SHALL BE FREE OF ALL VISIBLE OIL, GREASE, DUST, DIRT, MILL SCALE, RUST, COATING, OXIDES, CORROSION PRODUCTS AND OTHER FOREIGN MATTER OF AT LEAST 66-2/3% OF UNIT AREA. WHICH SHALL BE A SQUARE 3 IN. X 3 IN. (9 SQ. IN.). LIGHT SHADOWS, SLIGHT STREAKS, OR MINOR DISCOLORATIONS, CAUSED BY STAINS OF RUST, STAINS OF MILL SCALE, OR STAINS OF PREVIOUSLY APPLIED COATING IN LESS THAN 33-1/3% OF THE UNIT AREA IS ACCEPTABLE.
2. SHOULD THE CONTRACTOR CONDUCT ANY STORAGE, STAGING, SPOILING, OR OTHER PROJECT-RELATED ACTIVITIES ON PRIVATE PROPERTY, HE SHALL SUBMIT TO THE COUNTY A SIGNED PROPERTY RELEASE FOR EACH PROPERTY OWNER BEFORE BEGINNING WORK.
3. IF THE CONTRACTOR, HAVING BEEN ADVISED BY THE OWNER OR HIS REPRESENTATIVE THAT SUCH WORK REQUIRES INSPECTION OR TESTING, COVERS SUCH WORK BEFORE OBTAINING CONFIRMATION FROM OWNER THAT ALL REQUIRED INSPECTION OR TESTING HAS BEEN COMPLETED. THEN THE CONTRACTOR WILL BEAR ALL SUCH "EXPENSES."
4. THE CONTRACTOR SHALL PROVIDE TWO (2) WET/DRY BULB THERMOMETERS AND THE APPROPRIATE GRAPHS OR CHARTS FOR INTERPRETING BOTH THE RELATIVE HUMIDITY AND THE DEW POINT.
5. WHERE A BIN PLATE IS ATTACHED TO THE EXISTING STEEL ABUTMENTS, THE CONTRACTOR SHALL REMOVE, STORE, AND REMOUNT IT AFTER FINISHING PAINTING OPERATIONS, COST TO BE INCLUDED IN ITEM 573.01000X - STRUCTURAL STEEL PAINTING FIELD APPLIED TOTAL REMOVAL.
6. THE CONTRACTOR SHALL IMPLEMENT PROGRAMS AND PROCEDURES WHICH COMPLY WITH THE REQUIREMENTS OF THE SPECIFICATION AND ALL APPLICABLE FEDERAL, STATE, AND LOCAL OSHA AND EPA STANDARD REGULATIONS.
7. THE CONTRACTOR SHALL BE RESPONSIBLE FOR THE TREATMENT AND DISPOSAL OF WASTE.
8. THE CONTRACTOR SHALL BE RESPONSIBLE FOR THE COORDINATING OF ALL WORK WITH EXISTING UTILITIES IN THE PROPOSED WORK UNITS.
9. THE CONTRACTOR SHALL BE RESPONSIBLE FOR PROVIDING A TESTING SUBCONTRACTOR FOR LEAD MONITORING TESTING AS REQUIRED TO MEET THE INTENT OF THE SPECIFICATION. COST TO BE INCLUDED IN THE APPROPRIATE ITEMS OF WORK.
10. THE CONTRACTOR SHALL PERFORM ALL MAINTENANCE AND PROTECTION OF TRAFFIC FOR THE SITES BID. ALL OPERATIONS SHALL CONFORM TO THE NATIONAL MANUAL ON UNIFORM TRAFFIC CONTROL DEVICES FOR STREETS AND HIGHWAYS - 2009 EDITION (NATIONAL MUTCD) AND NEW YORK STATE SUPPLEMENT TO THE MUTCD. THE COST SHALL BE INCLUDED IN THE UNIT PRICE BID FOR ITEM 619.01nnn.

SPECIAL NOTE - RIGHT OF WAY

1. ALL WORK TO BE PERFORMED UNDER THIS CONTRACT WILL BE WITHIN THE PUBLIC RIGHT-OF-WAY (ROW) IN ACCORDANCE WITH SECTION 105-15 OF THE STANDARD SPECIFICATIONS. THE CONTRACTOR IS TO ASSURE HIMSELF THAT ALL WORK IS BEING PERFORMED WITHIN THE ROW, INCLUDING BUT NOT LIMITED TO VEHICLE ACCESS; STORAGE OF EQUIPMENT, MATERIALS, DEBRIS AND WASTE; LANDSCAPING; VEGETATION REMOVAL AND MANAGEMENT; GRADING, SEEDING AND THE INSTALLATION OF TURF; AND THE INSTALLATION OF ANY FENCES OR PROTECTIVE BARRIER.
2. IF CONTRACTOR IS UNABLE TO IDENTIFY THE LIMITS OF THE RIGHTS-OF-WAY WHEN THE CONTRACT CALLS FOR WORK IN THOSE VICINITIES, THE CONTRACTOR MUST CONTACT THE PROJECT ENGINEER FOR DEFINITIVE BOUNDARY DETERMINATIONS BEFORE ANY WORK MAY BE INITIATED AT THOSE LOCATIONS (STANDARD SPECIFICATIONS SECTIONS 105-10 AND 625).
3. IN ACCORDANCE WITH SECTION 105-15 OF THE STANDARD SPECIFICATIONS, RELEASES FOR ANY NON-ESSENTIAL CONTRACT WORK OUTSIDE OF THE EXISTING RIGHTS-OF-WAY, INCLUDING PLANTINGS, LANDSCAPING OR DRIVEWAY ENHANCEMENT, WILL BE PROVIDED BY THE PROJECT ENGINEER AND IN NO INSTANCE ARE TO BE SECURED BY THE CONTRACTOR. THE CONTRACTOR SHALL NOT INVADE UPON PRIVATE PROPERTIES, LANDS OR BUILDINGS OUTSIDE OF THE RIGHTS-OF-WAY FOR ANY REASON WITHOUT FIRST SECURING WRITTEN PERMISSION FROM THE PROPERTY OWNER (STANDARD SPECIFICATIONS SECTION 105-15).
4. THE CONTRACTOR WILL BE HELD LIABLE FOR ANY DAMAGES DONE. ANY SUCH INJURIES OR DAMAGES SHALL BE SATISFACTORILY REPAIRED OR ITEMS REPLACED AT THE CONTRACTOR'S EXPENSE (STANDARD SPECIFICATIONS SECTION 107-08).

SPECIAL NOTES

1. THE NORTHERN LONG EARED BAT (MYOTIS SEPTENTRIONALIS) IS LISTED AS A FEDERALLY THREATENED SPECIES STATEWIDE. THIS PROJECT IS NOT ANTICIPATED TO INVOLVE THE REMOVAL OF TREES GREATER THAN THREE (2) INCHES IN DIAMETER (DIAMETER BREST HEIGHT (DBH)). IF PROJECT CONDITIONS CHANGE AND TREE REMOVALS ARE NECESSARY, WHETHER UNDER CLEARING AND GRUBBING OR TREE REMOVALS, THE ENGINEER MUST BE NOTIFIED PRIOR TO THE START OF ANY TREE REMOVAL. TREE REMOVALS WILL BE ALLOWED ONLY AFTER COORDINATION AND APPROVAL BY THE ENGINEER IN CONSULTATION WITH THE CONSTRUCTION ENVIRONMENTAL COORDINATOR.
2. ALL BRIDGES HAVE THE POTENTIAL OF BEING SUMMER ROOSTING HABITAT FOR THE NORTHERN LONG-EARED BAT (NLEB). THE CONTRACTOR SHALL NOTIFY THE EIC AT LEAST 10 DAYS PRIOR TO THE START OF WORK AT EACH BRIDGE. A BRIDGE/BAT SURVEY WILL BE CONDUCTED BY THE COUNTY FOR THE PRESENCE OF THE BLEB FOR ANY BRIDGE WORK THAT WILL TAKE PLACE BETWEEN MARCH 31 AND OCTOBER 1 AND/OR INVOLVES ACCESS TO THE UNDERSIDE OF THE BRIDGE OR DRILLING DOWN TO THE UNDERSIDE OF THE BRIDGE, INCLUDING BRIDGE PAINTING AND WASHING. THE SURVEY WILL BE CONDUCTED AND RESULTS PROVIDED WITHIN SEVEN (7) DAYS OF THE CONTRACTOR'S NOTIFICATION. NO WORK ON THAT BRIDGE CAN COMMENCE UNTIL THE BRIDGE IS CLEARED THROUGH THE EIC.

DESCRIPTION	B.I.N.	AVERAGE VERTICAL CLEARANCE	STREAM DIRECTION	STREAM CLASS	ABRASIVE MEDIA ALLOWED
FREEDOM BRIDGE NO. 1, DELEVAN-ELTON (CR 21) ROAD OVER SOUTH BRANCH ELTON CREEK	B.I.N. 3321510	17 FT. ±	EAST	C(T)	F or S
EAST OTTO BRIDGE NO. 27, HAMMOND HILL ROAD OVER CONNOSARAULEY CREEK	B.I.N. 3321150	6 FT. ±	WEST	B(TS)	F
SOUTH VALLEY BRIDGE NO. 4, COUNTY ROAD 22 OVER BONE RUN	B.I.N. 3323210	8 FT±	NORTH	C(T)	F

- (S) SILICA, SAND OR OTHER TYPE OF NON-METALLIC ABRASIVE
(F) FERROUS METALLIC ABRASIVE (SSPC-A8-3)
(T) TROUT WATERS
(TS) TROUT SPAWNING

Greenman-Pedersen, Inc.
Engineering and Construction Services

In Western New York:
ROCHESTER (865) 466-4659 • **JAMESTOWN** (716) 469-2603
BUFFALO (716) 633-4644

GPI



SCALE: NONE	SID	DRAWN BY:	NO.
DATE: AUG 2019	GE8	CHECKED BY:	NO.
DWG NO.: 2	BUF-2019030.00	JOB NO.:	NO.
		BY	DATE

GENERAL NOTES

CATTARAUGUS DEPARTMENT OF PUBLIC WORKS
2020 BRIDGE PAINTING PROJECT
VARIOUS LOCATIONS IN CATTARAUGUS COUNTY

SHEET NO.

GN-1

WARNING: ALTERATIONS TO THIS DOCUMENT NOT CONFORMING TO SECTION 7208, SUBDIVISION 2, STATE EDUCATION LAW ARE PROHIBITED.

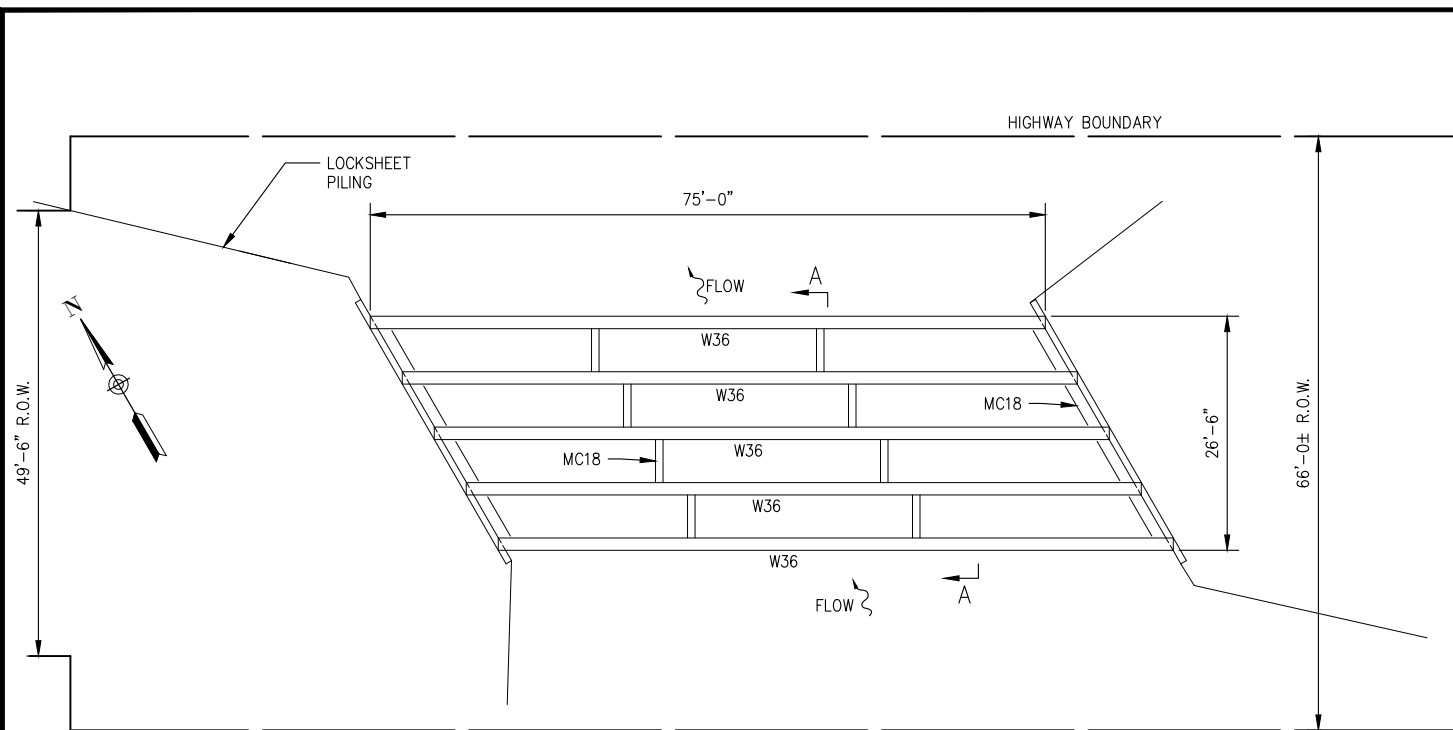

FRAMING PLAN
NOT TO SCALE

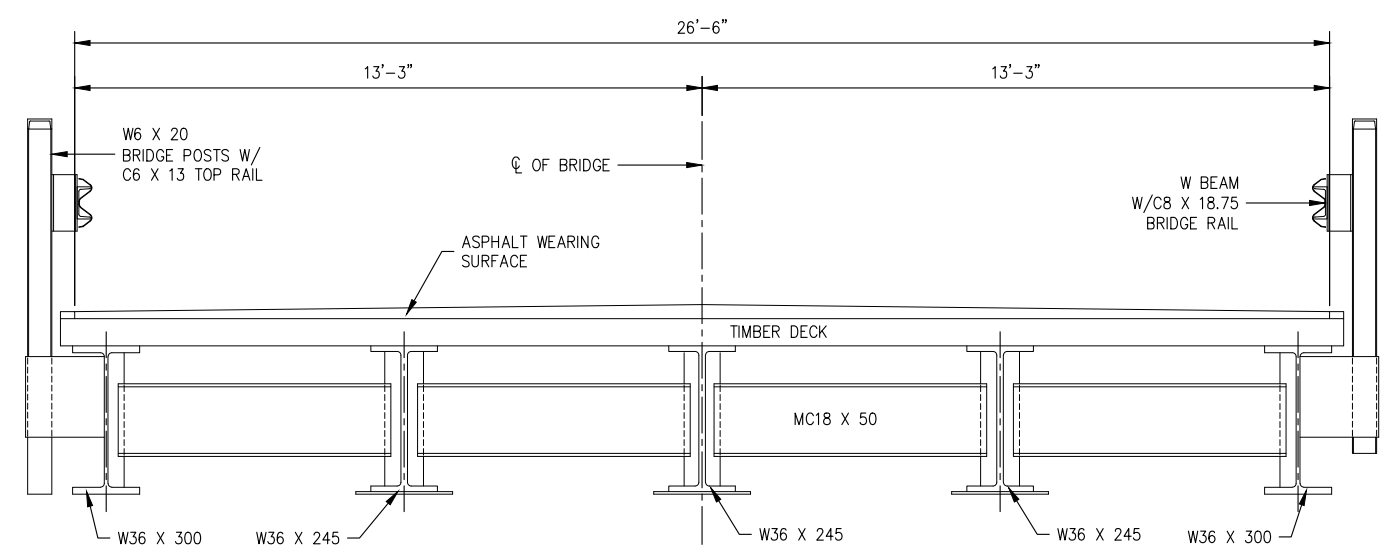

BRIDGE SECTION A-A
NOT TO SCALE

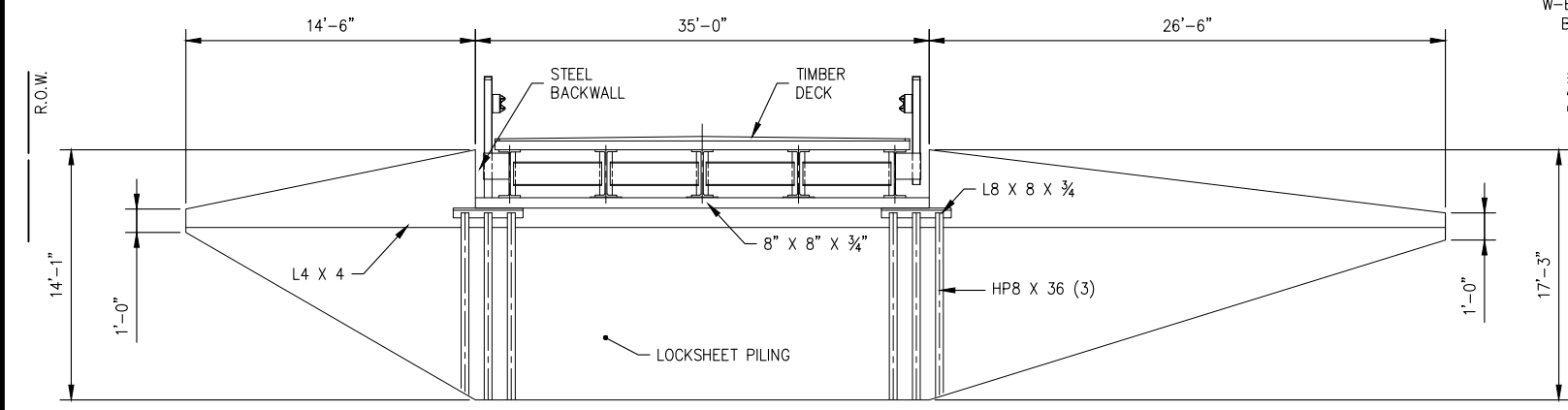

EAST TRANSVERSE ELEVATION
NOT TO SCALE

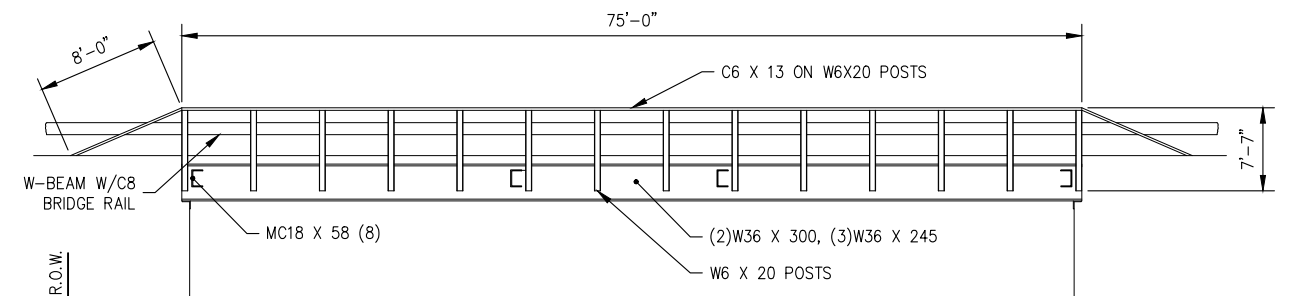

BRIDGE ELEVATION
NOT TO SCALE

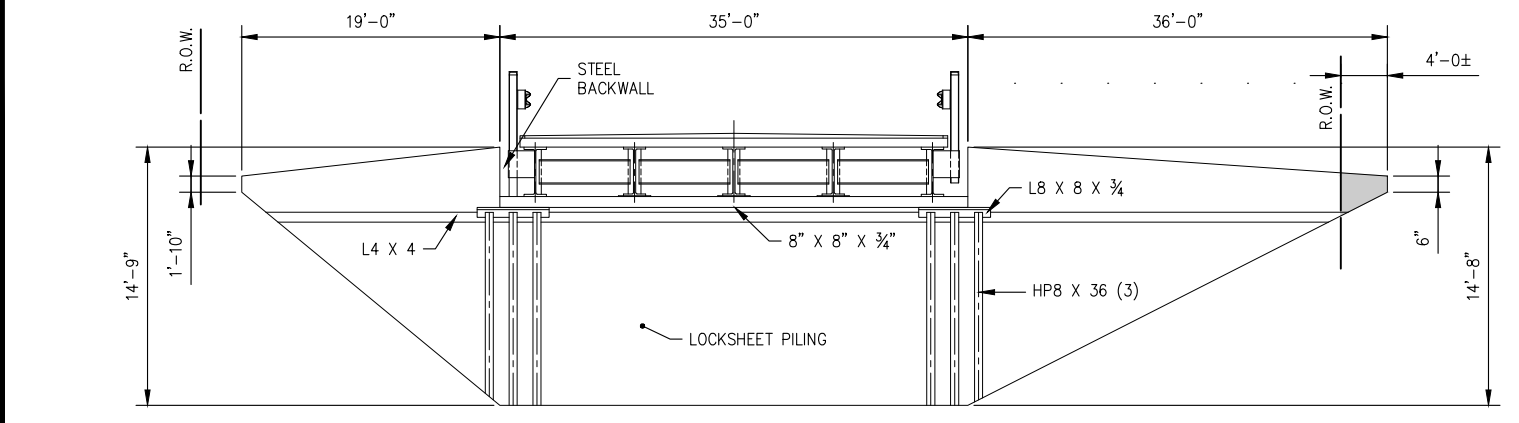

WEST TRANSVERSE ELEVATION

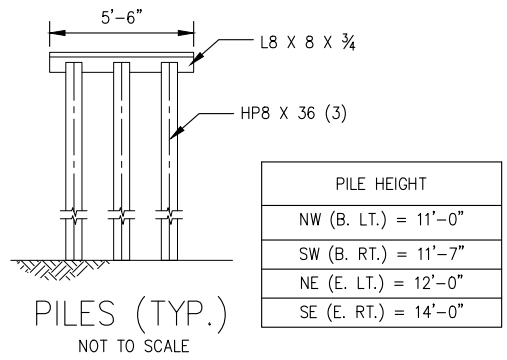

AREA NOT TO BE PAINTED

Greenman-Pedersen, Inc.
Engineering and Construction Services

In Western New York:
ROCHESTER (585) 486-4859
BUFFALO (716) 633-4844

JAMESTOWN (716) 488-2803

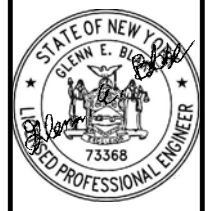

SCALE:	DATE:	DRAWN BY:	CHECKED BY:	JOB NO.:	DATE:
NONE	AUG 2019	CEB	CEB	BUF-2019030.00	
DWG NO.:	NO.	BY:	REVISIONS:		
5					

BIN 3321510
FREEDOM BRIDGE No. 1
DELEVAN-ELTON RD OVER
S. BRANCH ELTON CREEK

CATTARAUGUS DEPARTMENT OF PUBLIC WORKS
2020 BRIDGE PAINTING PROJECT
VARIOUS LOCATIONS IN CATTARAUGUS COUNTY

SHEET NO.
PL-1

WARNING: ALTERATIONS TO THIS DOCUMENT NOT CONFORMING TO SECTION 2001 SUBDIVISION 2 STATE EDUCATION LAW ARE PROHIBITED

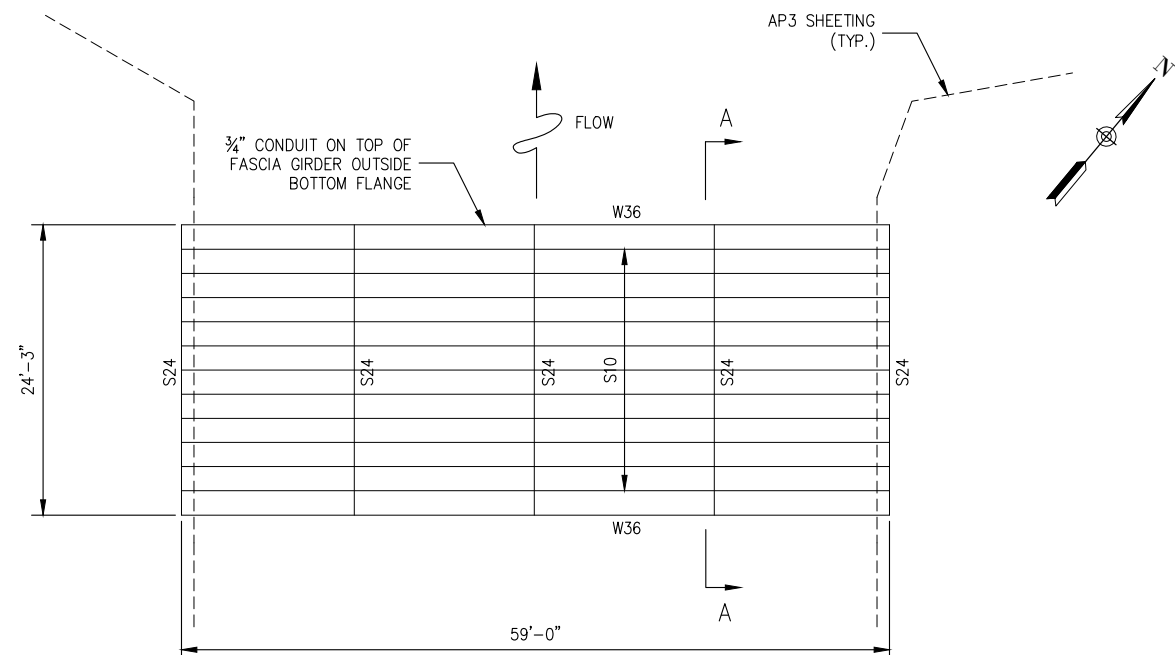

FRAMING PLAN
NOT TO SCALE

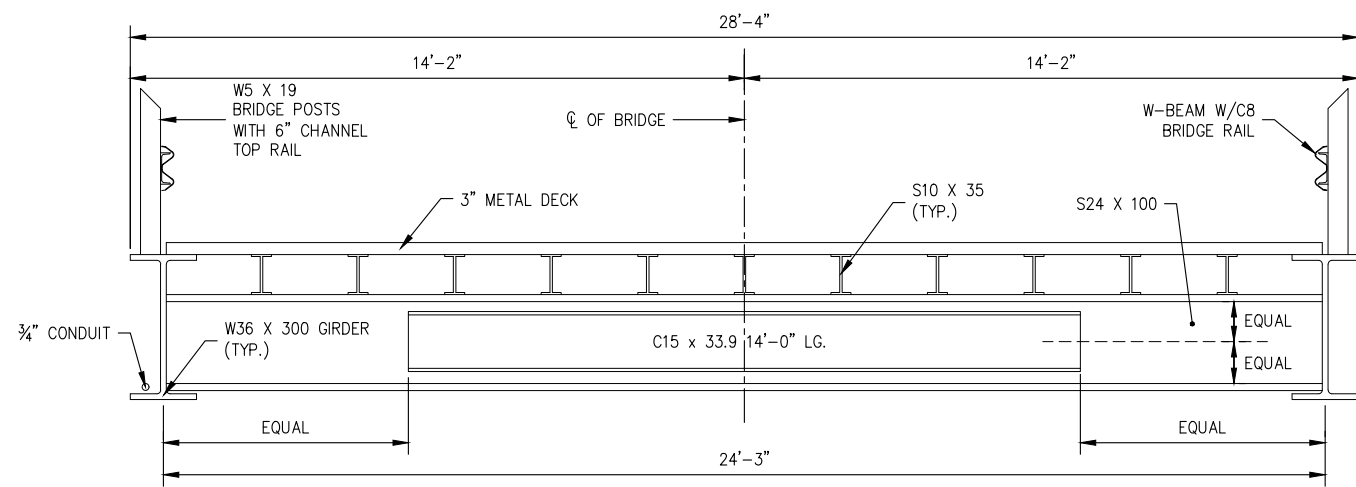

BRIDGE SECTION A-A
NOT TO SCALE

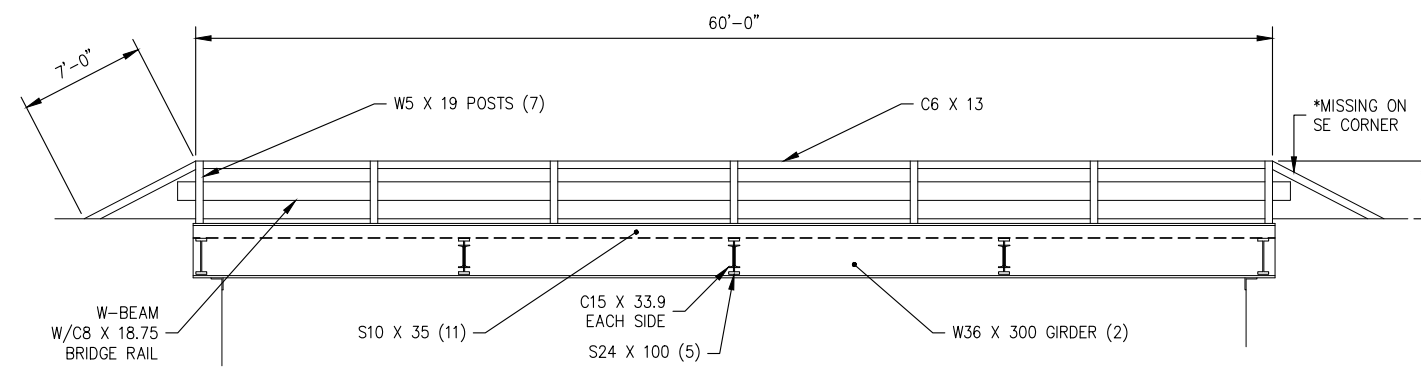

BRIDGE ELEVATION
NOT TO SCALE

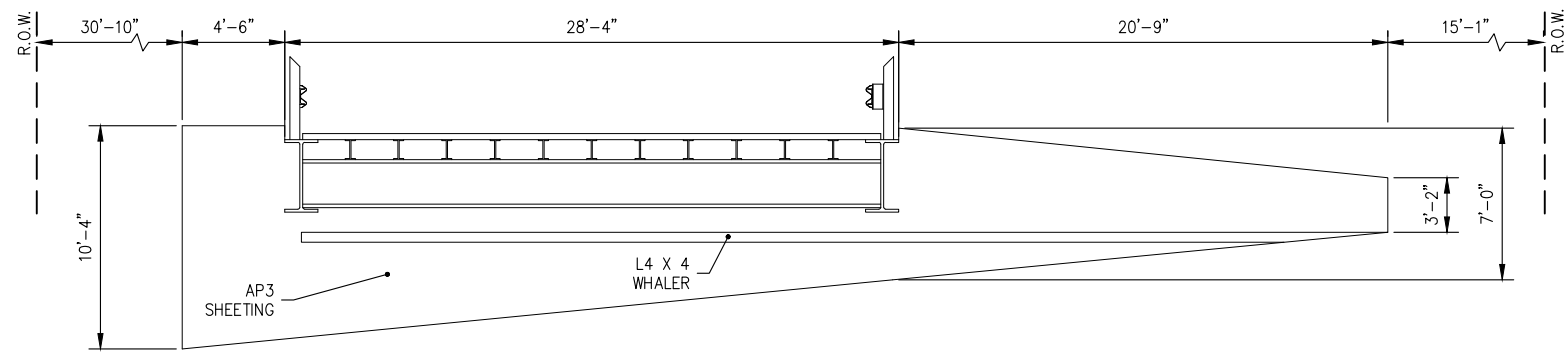

WEST TRANSVERSE ELEVATION
NOT TO SCALE

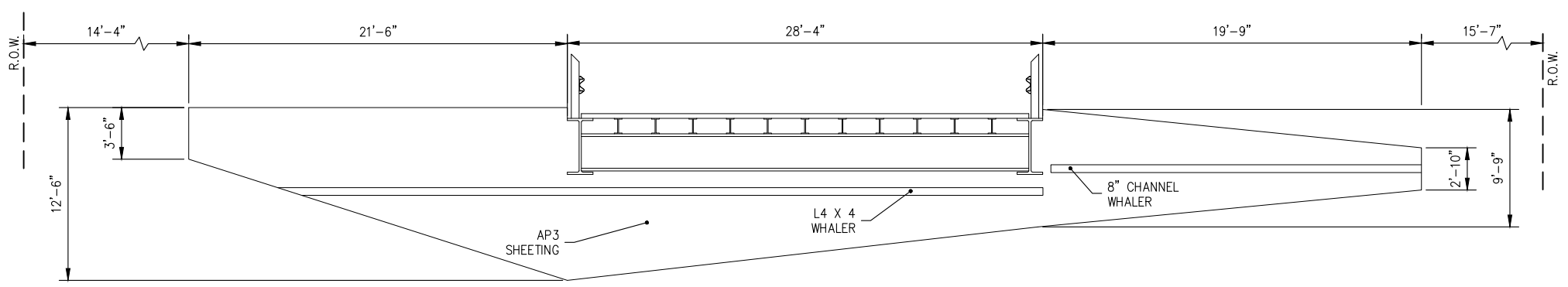

EAST TRANSVERSE ELEVATION
NOT TO SCALE

Greenman-Pedersen, Inc.
Engineering and Construction Services

In Western New York:
ROCHESTER (585) 486-4859
BUFFALO (716) 833-4844

JAMESTOWN (716) 488-2803



SCALE:	NONE	DRAWN BY:	SID
DATE:	AUG 2019	CHECKED BY:	GEB
DWG NO.:	3	JOB NO.:	BUF-2019030.00
NO.		BY:	
		DATE:	
REVISIONS:			

BIN 3321150
EAST OTTO BRIDGE No. 27
HAMMOND HILL ROAD OVER
CONNORSAULEY CREEK

CATTARAUGUS DEPARTMENT OF PUBLIC WORKS
2020 BRIDGE PAINTING PROJECT
VARIOUS LOCATIONS IN CATTARAUGUS COUNTY

SHEET NO.
PL-2

WARNING: ALTERATIONS TO THIS DOCUMENT NOT CONFORMING TO SECTION 205 SUBSECTION 2 STATE EDUCATION LAW ARE PROHIBITED

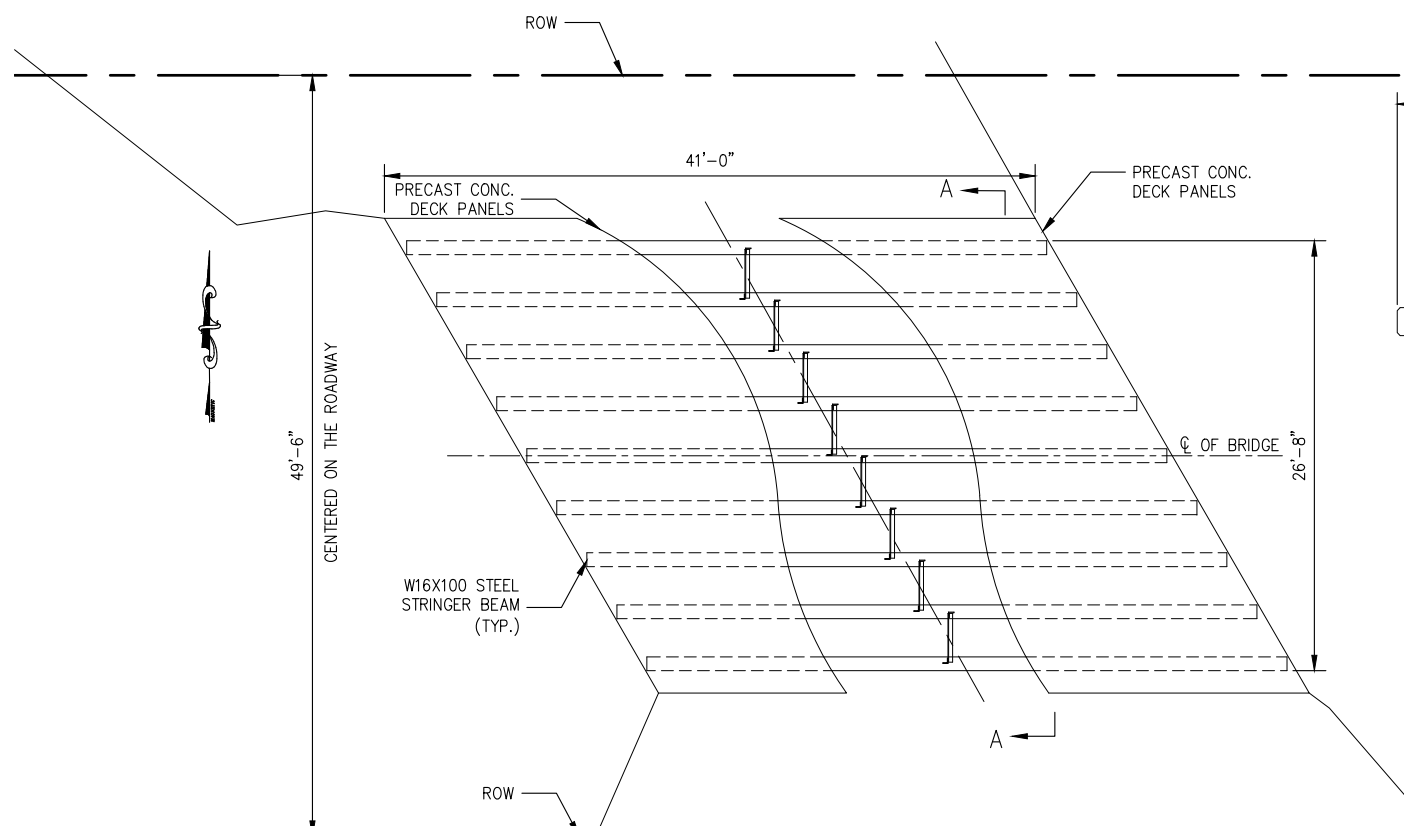

SUPERSTRUCTURE DETAIL
SCALE: NOT TO SCALE

NOTE: WALL OUTSIDE OF ROW SHALL NOT BE PAINTED

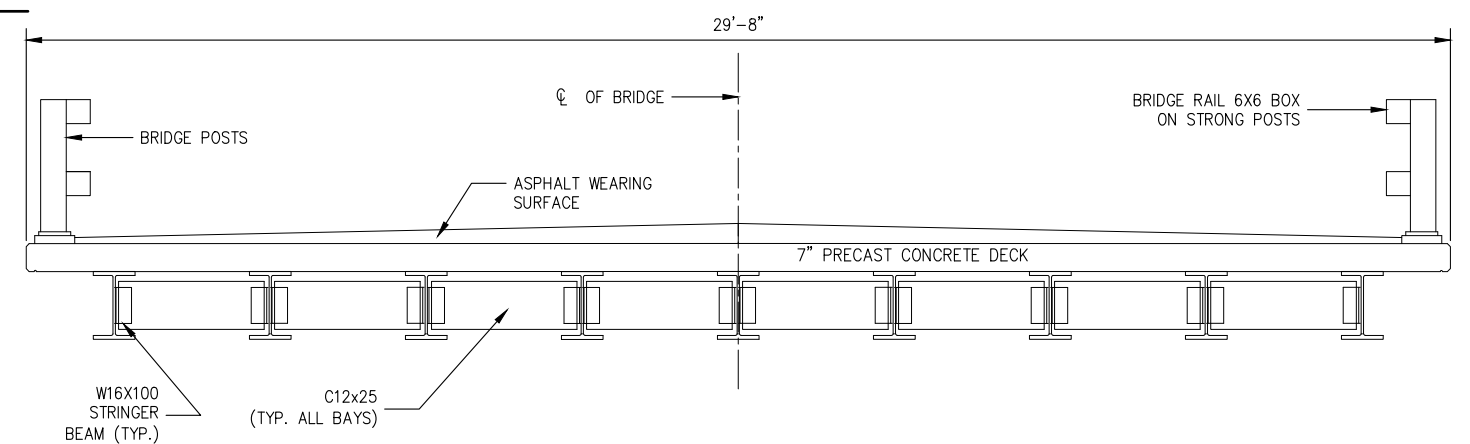

BRIDGE SECTION A-A
NOT TO SCALE

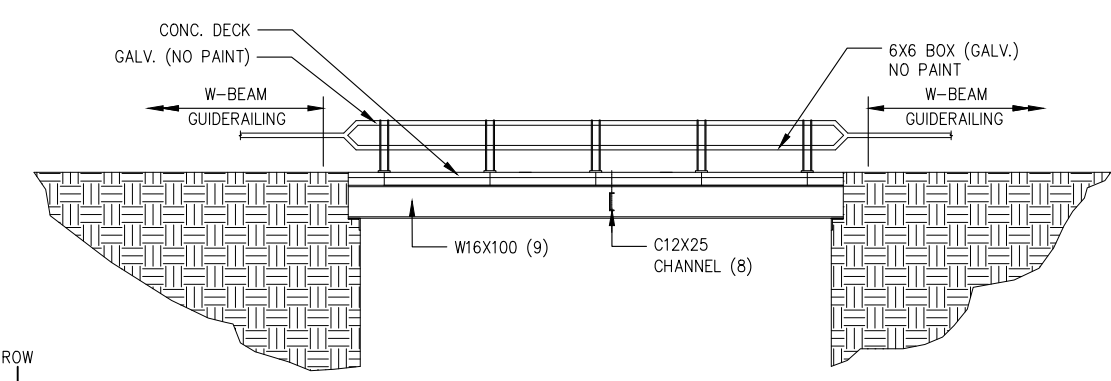

BRIDGE ELEVATION
NOT TO SCALE

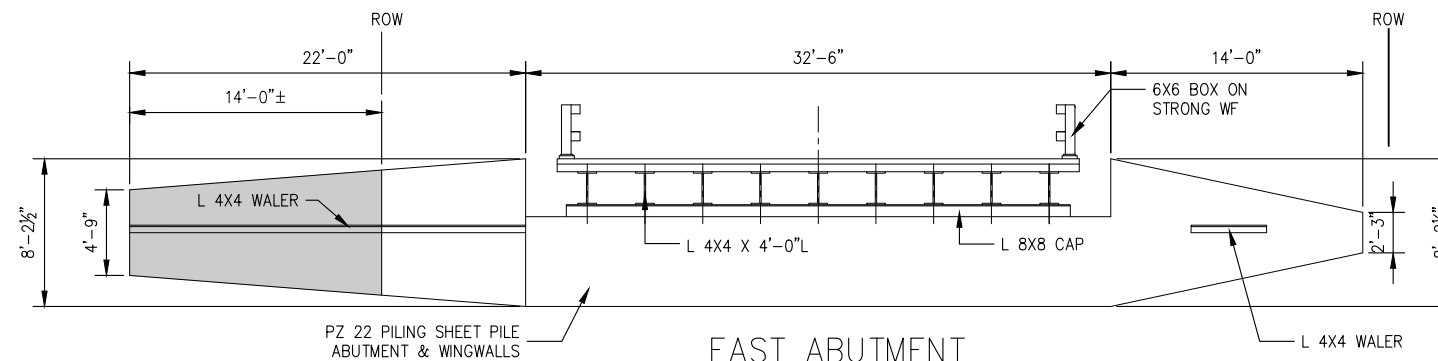

EAST ABUTMENT
NOT TO SCALE

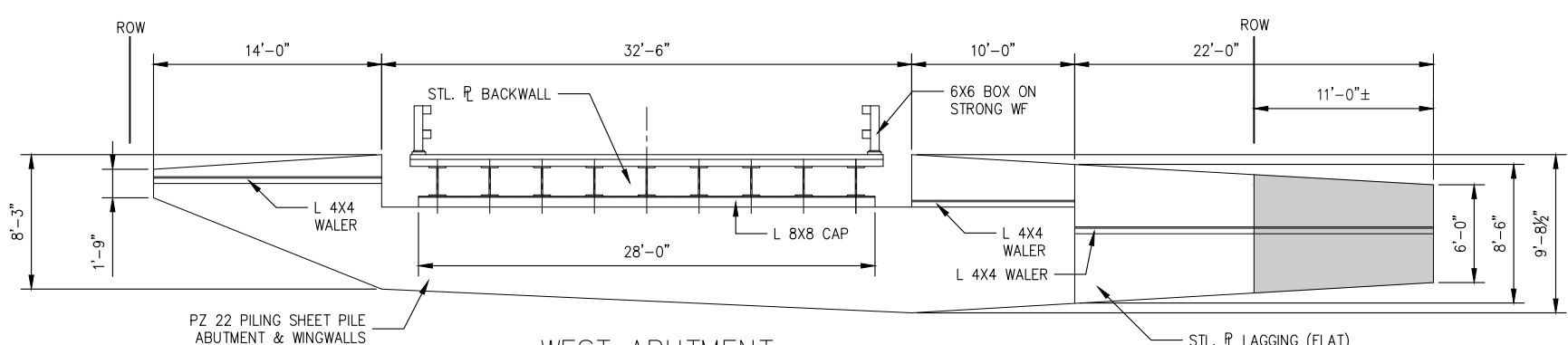

WEST ABUTMENT
NOT TO SCALE

AREA NOT TO BE PAINTED

Greenman-Pedersen, Inc.
Engineering and Construction Services
In Western New York:
ROCHESTER (865) 486-4859
JAMESTOWN (716) 486-2803
BUFFALO (716) 633-4844



SCALE: NONE	DRAWN BY: SID	NO.	NO.
DATE: NOV 2019	CHECKED BY: GEB	NO.	NO.
DWG NO.: x-x	JOB NO.:	BY:	DATE:
REVISIONS:			

B.I.N. 3323210
SOUTH VALLEY BRIDGE No. 4
COUNTY RD NO. 35 OVER BONE CREEK
CATTARAUGUS DEPARTMENT OF PUBLIC WORKS
2020 BRIDGE PAINTING PROJECT
VARIOUS LOCATIONS IN CATTARAUGUS COUNTY

SHEET NO.

PL-3

WARNING: ALTERATIONS TO THIS DOCUMENT NOT CONFORMING TO SECTION 7209, SUBDIVISION 5, STATE EDUCATION LAW, ARE PROHIBITED.

H:\2019\pl-20190303.D cadwin 2020 bridge painting program\2020\Design\Drawings - PL-3 2020\DWG\PL-3.dwg Friday, 21 February 2020 10:17AM

GENERAL NOTES

- THE TYPICAL DETAILS DEPICTED ON THE STANDARD SHEETS AND IN THE MUTCD, REFLECT THE MINIMUM REQUIREMENTS.
- THE CONTRACTOR MUST SUBMIT TO THE ENGINEER, IN WRITING, PROPOSED REVISIONS TO THE TRAFFIC CONTROL PLAN FOR REVIEW AND APPROVAL BY THE REGIONAL DIRECTOR OR HIS/HER DESIGNEE FIVE (5) WORK DAYS PRIOR TO THE PLANNED IMPLEMENTATION OF SUCH PROPOSED REVISIONS, EXCEPT FOR CHANGES THAT ALTER THE SCOPE OF THE TRAFFIC CONTROL PLAN. SUCH CHANGES IN SCOPE MUST BE SUBMITTED TO THE ENGINEER FOR APPROVAL BY THE REGIONAL DIRECTOR OR HIS/HER DESIGNEE THIRTY (30) WORKING DAYS PRIOR TO IMPLEMENTATION OF SUCH REVISIONS.
- THE CONTRACTOR SHALL PROVIDE THE ENGINEER, IN WRITING, WITH THE NAMES, ADDRESSES, AND TELEPHONE NUMBERS OF STAFF WHO ARE AUTHORIZED TO SECURE LABOR, MATERIALS, AND EQUIPMENT FOR EMERGENCY REPAIRS OUTSIDE NORMAL WORKING HOURS. THE ENGINEER WILL PROVIDE THE SUBMITTED INFORMATION TO REGIONAL MANAGEMENT, THE NEW YORK STATE POLICE, THE RESIDENT ENGINEER, AND THE LOCAL POLICE.

ACTIVITY AREA

- THE CONTRACTOR SHALL MAINTAIN A MINIMUM 500 FT. LONGITUDINAL DISTANCE BETWEEN CONSTRUCTION OPERATIONS ON ALTERNATE SIDES OF THE ROADWAY, UNLESS OTHERWISE APPROVED BY THE ENGINEER.
- WHEN TWO OR MORE AREAS ARE ADJACENT, OVERLAP, OR ARE IN CLOSE PROXIMITY, THE CONTRACTOR SHALL ENSURE THERE ARE NO CONFLICTING SIGNS AND THAT LANE CONTINUITY IS MAINTAINED THROUGHOUT ALL WORK AREAS.

SIGNS

- THE LOCATIONS OF THE SIGNS SHOWN ON THE WORK ZONE TRAFFIC CONTROL PLANS AND DETAILS MAY BE ADJUSTED BASED ON SIGHT DISTANCE AND OTHER CONSIDERATIONS. THE FINAL LOCATIONS OF SIGNS ARE SUBJECT TO APPROVAL OF THE ENGINEER.
- ANY EXISTING SIGNS, INCLUDING OVERHEAD SIGNS, WHICH CONFLICT WITH THE TEMPORARY TRAFFIC CONTROL SIGN LAYOUT SHALL BE COVERED, REMOVED, STORED OR RESET, AS APPROVED BY THE ENGINEER. ALL APPROPRIATE EXISTING SIGNS SHALL BE RESTORED TO THEIR ORIGINAL CONDITION AND/OR LOCATION UNLESS OTHERWISE REPLACED IN THIS CONTRACT.
- SIGNS AT OR NEAR INTERSECTIONS SHALL BE PLACED SO THAT THEY DO NOT OBSTRUCT A MOTORIST'S LINE OF SIGHT.
- ALL WARNING AND REGULATORY SIGNS SHALL BE POSTED ON BOTH SIDES OF MULTI-LANE DIVIDED HIGHWAYS, MULTI-LANE RAMPS, AND ONE-WAY STREETS. IN CASES WHERE LANE RESTRICTIONS REDUCE THE TRAVEL LANE TO ONE LANE, SIGNS SHALL BE POSTED ON THE RIGHT SIDE OF THE ACTIVE TRAVEL LANE, UNLESS OTHERWISE AUTHORIZED BY THE ENGINEER.
- SIGNS MOUNTED ON THE MEDIAN OF DIVIDED HIGHWAYS WHERE MEDIAN BARRIER IS IN PLACE MAY BE MOUNTED ON THE BARRIER WITH A SADDLE TYPE BRACKET. LAYING THE SIGN DOWN IN A HORIZONTAL POSITION IS NOT PERMITTED.
- THE DIMENSIONS OF WORK ZONE TRAFFIC CONTROL SIGNS ARE DESCRIBED IN THE MUTCD. ANY CHANGES TO THE DIMENSIONS SHALL BE APPROVED BY THE ENGINEER OR BY HIS/HER DESIGNEE.
- BRIDGES ARE TO REMAIN OPEN AT ALL TIMES. THE W-BEAM GUIDE RAIL MUST BE REMOVED BEFORE PAINTING AND REINSTALLED BEFORE TRAFFIC IS PLACED ON THAT SIDE OF THE BRIDGE.

CHANNELIZING DEVICES

- WHERE POSSIBLE ALL CHANNELIZING AND GUIDING DEVICES ARE TO BE PLACED SO AS TO PROVIDE A MINIMUM 2 FT. LATERAL CLEARANCE TO THE TRAVELED WAY.

PUBLIC ACCESS

- PROPERTY OWNERS WHOSE DRIVEWAYS WILL BE MADE INACCESSIBLE SHALL BE NOTIFIED BY THE CONTRACTOR AT LEAST 24 HOURS PRIOR TO RESTRICTING USE OF THE DRIVEWAY. FOR MULTIPLE ACCESS PROPERTIES, AT LEAST ONE DRIVEWAY SHALL BE OPEN AT ALL TIMES. ACCESS SHALL BE RESTORED TO ALL DRIVEWAYS AS SOON AS POSSIBLE.

LANE CLOSURES

- THE CONTRACTOR SHALL LOCATE LANE CLOSURES TO PROVIDE OPTIMUM VISIBILITY, I.E. BEFORE CURVES AND CRESTS, TO THE EXTENT CONDITIONS PERMIT.
- THE ENGINEER MAY REQUIRE THAT ALL LANES BE RE-OPENED AT ANY TIME IF THE ROUTE IS NEEDED FOR EMERGENCY PURPOSES. THIS COULD INCLUDE INCIDENTS AT LOCATIONS OUTSIDE THE CONTRACT LIMITS.

LANE WIDTHS

- UNLESS AUTHORIZED BY THE ENGINEER, THE MINIMUM LANE WIDTHS FOR WORK ZONE TRAVEL LANES SHALL BE AS FOLLOWS: FREEWAYS AND/OR EXPRESSWAYS IS 11 FT. THE MINIMUM LANE WIDTH FOR ALL OTHER TYPES OF ROADWAYS IS 10 FT.

BARRIER/SHADOW VEHICLES

- BARRIER AND SHADOW VEHICLES SHALL BE REQUIRED AS PER STANDARD SHEET TITLED "WORK ZONE TRAFFIC CONTROL LEGENDS AND NOTES" (619-11).
- NO WORK ACTIVITY, EQUIPMENT, VEHICLES AND/OR MATERIALS SHALL BE LOCATED BETWEEN THE BARRIER OR SHADOW VEHICLE AND THE ACTIVE WORK AREA (ROLL AHEAD DISTANCE).
- THE CONTRACTOR MAY BE REQUIRED TO PROVIDE A BARRIER VEHICLE IN CONJUNCTION WITH POLICE PRESENTS IN THE WORK ZONE, TO BE INCLUDED IN THE UNIT BID PRICE FOR BASIC WORK ZONE TRAFFIC CONTROL.

Standard Sheet M619-11

TABLE NY6H-3
ADVANCE WARNING SIGN SPACING (ENGLISH)

ROAD TYPE	DISTANCE BETWEEN SIGNS			SIGN LEGEND	
	A (FT)	B (FT)	C (FT)	XX	YY
URBAN (<30 MPH*)	100	100	100	AHEAD	AHEAD
URBAN (35-40 MPH*)	200	200	200	AHEAD	AHEAD
URBAN (>45 MPH*)	350	350	350	1000 FT	AHEAD
RURAL	500	500	500	1500 FT	1000 FT
EXPRESSWAY / FREEWAY	1,000	1,500	2,640	1 MILE	1/2 MILE

* PRECONSTRUCTION POSTED SPEED LIMIT

TABLE NY6H-3
ADVANCE WARNING SIGN SPACING (METRIC)

ROAD TYPE	DISTANCE BETWEEN SIGNS			SIGN LEGEND	
	A (m)	B (m)	C (m)	XX	YY
URBAN (<30 MPH*)	30	30	30	AHEAD	AHEAD
URBAN (35-40 MPH*)	60	60	60	AHEAD	AHEAD
URBAN (>45 MPH*)	100	100	100	1000 FT	AHEAD
RURAL	150	150	150	1500 FT	1000 FT
EXPRESSWAY / FREEWAY	300	450	800	1 MILE	1/2 MILE

* PRECONSTRUCTION POSTED SPEED LIMIT

URBAN:
(MEETS MORE THAN 1 OF THE FOLLOWING CRITERIA) SIDEWALKS, BICYCLE USAGE, CURBING, CLOSED DRAINAGE SYSTEMS, DRIVEWAY DENSITIES GREATER THAN 24 DRIVEWAYS/MI, MINOR COMMERCIAL DRIVEWAY DENSITIES OF 10 DRIVEWAYS/MI OR GREATER, MAJOR COMMERCIAL DRIVEWAYS, NUMEROUS RIGHT OF WAY CONSTRAINTS, HIGH DENSITY OF CROSS STREETS, 85TH PERCENTILE SPEEDS OF 45 MPH OR LESS.

RURAL:
ANY AREA NOT EXHIBITING MORE THAN ONE OF ABOVE CHARACTERISTICS.

EXPRESSWAY:
DIVIDED HIGHWAYS FOR THROUGH TRAFFIC WITH FULL OR PARTIAL CONTROL OF ACCESS AND GENERALLY WITH GRADE SEPARATIONS AT MAJOR CROSSROADS.

FREEWAYS/INTERSTATE:
LOCAL OR INTERREGIONAL HIGH-SPEED, DIVIDED, HIGH-VOLUME FACILITIES WITH FULL OR PARTIAL CONTROL OF ACCESS.

WORK DURATION DEFINITIONS

LONG-TERM STATIONARY IS WORK THAT OCCUPIES A LOCATION MORE THAN 3 CONSECUTIVE DAYS.

INTERMEDIATE-TERM STATIONARY IS WORK THAT OCCUPIES A LOCATION MORE THAN ONE DAYLIGHT PERIOD UP TO 3 CONSECUTIVE DAYS, OR NIGHTTIME WORK LASTING MORE THAN 1 HOUR.

SHORT-TERM STATIONARY IS DAYTIME WORK THAT OCCUPIES A LOCATION FOR MORE THAN 1 HOUR WITHIN A SINGLE DAYLIGHT PERIOD.

SHORT DURATION IS WORK THAT OCCUPIES A LOCATION UP TO 1 HOUR.

MOBILE IS WORK THAT MOVES INTERMITTENTLY OR CONTINUOUSLY.

TABLE 6C-2
LONGITUDINAL BUFFER SPACE

PRECONSTRUCTION POSTED SPEED LIMIT (MPH)	DISTANCE
25	155 FT
30	200 FT
35	250 FT
40	305 FT
45	360 FT
50	425 FT
55	495 FT
60	570 FT
65	645 FT

TABLE 6C-3
TAPER LENGTH CRITERIA FOR TEMP. TRAFFIC CONTROL ZONES

TYPE OF TAPER	TAPER LENGTH (L)
MERGING TAPER	L
SHIFTING TAPER	L/2
SHOULDER TAPER	L/3
ONE-LANE, TWO-WAY TRAFFIC TAPER	100 FT MAXIMUM
DOWNSTREAM TAPER	100 FT PER LANE

TABLE 6H-4 FORMULAS FOR DETERMINING TAPER LENGTHS

SPEED LIMIT (S) (MPH)	TAPER LENGTH (L) (FEET)
(40 MPH) OR LESS	$L = WS^2/60$
(45 MPH) OR MORE	$L = WS$

L = TAPER LENGTH
W = WIDTH OF OFFSET (FT)
S = PRE CONSTRUCTION POSTED SPEED LIMIT (MPH)

STANDARD TAPER LENGTHS

LATERAL SHIFT OF TRAFFIC FLOW PATH	TEMPORARY TRAFFIC CONTROL ZONE POSTED SPEED LIMIT										
	(20 MPH)	(25 MPH)	(30 MPH)	(35 MPH)	(40 MPH)	(45 MPH)	(50 MPH)	(55 MPH)	(60 MPH)	(65 MPH)	(70 MPH)
4	30	45	60	85	110	180	200	220	240	260	280
5	35	55	75	105	135	225	250	275	300	325	350
6	40	65	90	125	160	270	300	330	360	390	420
7	50	75	105	145	190	315	350	385	420	455	490
8	55	85	120	165	215	360	400	440	480	520	560
9	60	95	135	185	240	405	450	495	540	585	630
10	70	105	150	205	270	450	500	550	600	650	700
11	75	115	165	225	295	495	550	605	660	715	770
12	80	125	180	245	320	540	600	660	720	780	840

TABLE NY1-A
BARRIER VEHICLE USE REQUIREMENTS
(LONG TERM, INTERMEDIATE TERM, AND SHORT TERM STATIONARY CLOSURES)

CLOSURE TYPE	EXPOSURE CONDITION ¹	USE REQUIREMENTS ^{4,5}			
		FREEWAY	NON-FREEWAY (PRECONSTRUCTION POSTED SPEED LIMIT)		
			> 45 MPH	35-40 MPH	< 30 MPH
LANE CLOSURE	WORKERS ON FOOT OR IN VEHICLES EXPOSED TO TRAFFIC	REQUIRED ³	REQUIRED ³	REQUIRED ³	OPTIONAL ²
	NON-TRAVERSABLE HAZARD (IE. EQUIPMENT, MATERIALS, EXCAVATION) ONLY NO WORKERS EXPOSED	REQUIRED ³	REQUIRED ³	OPTIONAL ²	OPTIONAL ²
SHOULDER CLOSURE	WORKERS ON FOOT OR IN VEHICLES EXPOSED TO TRAFFIC	REQUIRED ³	REQUIRED ³	OPTIONAL ²	OPTIONAL ²
	NON-TRAVERSABLE HAZARD (IE. EQUIPMENT, MATERIALS, EXCAVATION) ONLY NO WORKERS EXPOSED	REQUIRED ³	OPTIONAL ²	OPTIONAL ²	OPTIONAL ²

- THE EXPOSURE CONDITIONS DESCRIBED IN TABLE NY1-A ASSUMES THERE IS NO POSITIVE PROTECTION (TEMPORARY TRAFFIC BARRIER) PRESENT. WHERE WORKERS OR HAZARDS ARE PROTECTED BY A TEMPORARY TRAFFIC BARRIER, BARRIER VEHICLES ARE NOT REQUIRED.
- WHERE THE REQUIREMENT IS "OPTIONAL", EITHER A BARRIER VEHICLE OR THE STANDARD LONGITUDINAL BUFFER SPACE (TABLE 6C-2) SHALL BE PROVIDED.
- REQUIREMENTS SHALL INCLUDE PROVIDING A SEPARATE BARRIER VEHICLE FOR EACH CLOSED LANE AND EACH CLOSED PAVED SHOULDER 8' OR GREATER IN WIDTH. IF THE WORK SPACE MOVES WITHIN THE STATIONARY CLOSURE, THE BARRIER VEHICLE SHALL BE REPOSITIONED ACCORDINGLY. BARRIER VEHICLES PROTECTING NON-TRAVERSABLE HAZARDS SHALL REMAIN IN PLACE DURING BOTH WORKING AND NON-WORKING HOURS UNTIL THE HAZARD NO LONGER EXISTS. EXCEPTIONS TO THESE REQUIREMENTS MAY BE MADE, AS APPROVED BY THE REGIONAL DIRECTOR OR HIS/HER DESIGNEE WHERE BARRIER VEHICLE PLACEMENT WOULD BE INEFFECTIVE OR WOULD INTERFERE WITH THE SAFE OPERATION OF TRAFFIC.
- BARRIER VEHICLES ARE NOT REQUIRED FOR MILLING AND/OR PAVING OPERATIONS, BUT THE STANDARD LONGITUDINAL BUFFER SPACE (TABLE 6C-2) SHALL BE PROVIDED.
- BARRIER VEHICLES ARE NOT REQUIRED FOR FLAGGING OPERATIONS, BUT THE STANDARD LONGITUDINAL BUFFER SPACE (TABLE 6C-2) SHALL BE PROVIDED.

TABLE NY2-A
PLACEMENT DISTANCE FOR BARRIER VEHICLES

PRECONSTRUCTION POSTED SPEED LIMIT (MPH)	PLACEMENT DISTANCE (FT.)			
	BARRIER VEHICLES*			
	(18000 LBS.)		(24000 LBS.)	
	MINIMUM	MAXIMUM	MINIMUM	MAXIMUM
> 55	100 FT.	200 FT.	100 FT.	200 FT.
45 - 55	100 FT.	200 FT.	85 FT.	165 FT.
< 45	85 FT.	165 FT.	50 FT.	100 FT.

* AS DEFINED IN NYS DOT STANDARD SPECIFICATION 619: BARRIER VEHICLE - VEHICLE USED FOR STATIONARY SHOULDER CLOSURES, LANE CLOSURES, AND OTHER STATIONARY WORK ZONES. MINIMUM DISTANCE SHOWN REFLECTS THE ACTUAL ROLL AHEAD DISTANCE FROM MANUFACTURER.

Greenman-Pedersen, Inc.
Engineering and Construction Services

In Western New York:
ROCHESTER (865) 466-4659
BUFFALO (716) 633-4844
JAMESTOWN (716) 469-2803

GPI



SCALE: NONE	SID	DRAWN BY:
DATE: AUG 2019	GEB	CHECKED BY:
DWG NO.: 6		JOB NO.:
		NO.:
		BY DATE
		REVISIONS:

WORK ZONE TRAFFIC CONTROL
CATTARAUGUS DEPARTMENT OF PUBLIC WORKS
2020 BRIDGE PAINTING PROJECT
VARIOUS LOCATIONS IN CATTARAUGUS COUNTY

SHEET NO.

WZTC-1

WARNING: ALTERATIONS TO THIS DOCUMENT NOT CONFORMING TO SECTION 709, SUBDIVISION 2 STATE EDUCATION LAW ARE PROHIBITED.

SHOULDER CLOSURE

SHORT OR INTERMEDIATE TERM STATIONARY
2-LANE 2-WAY ROADWAY
NOT TO SCALE

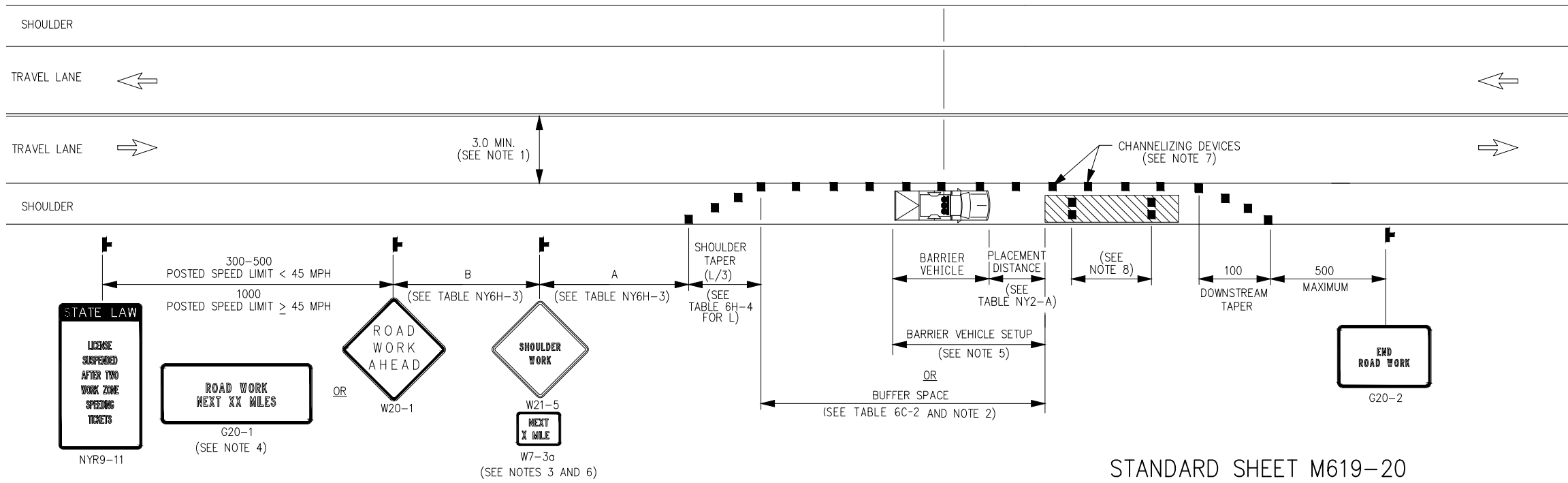

STANDARD SHEET M619-20

SHOULDER CLOSURE

SHORT OR INTERMEDIATE TERM STATIONARY
2-LANE 2-WAY ROADWAY
NOT TO SCALE

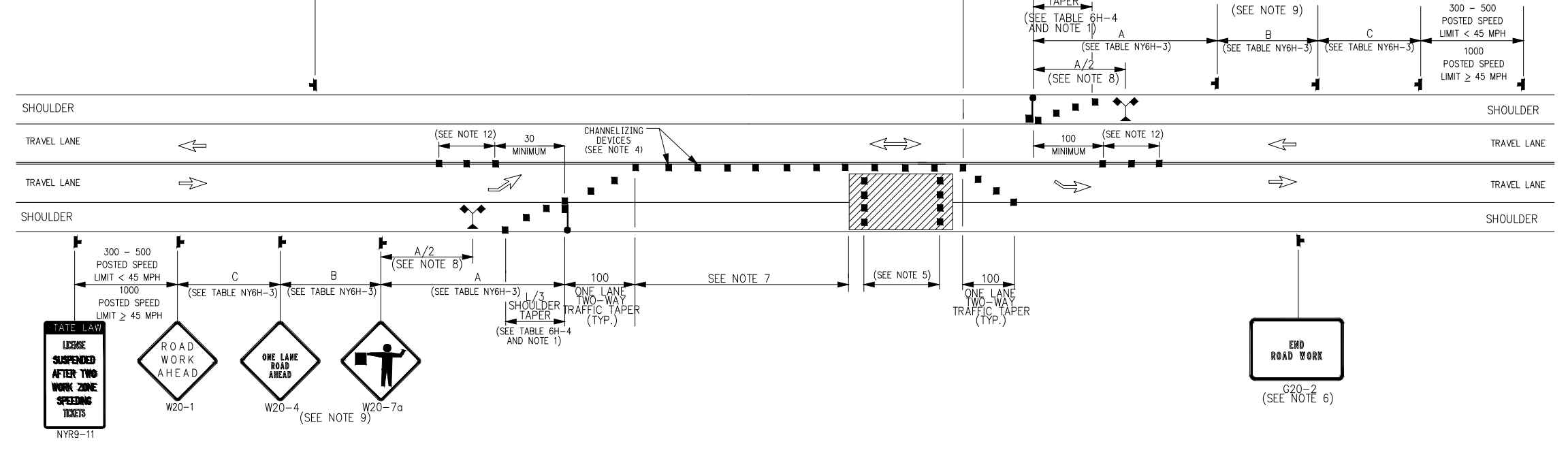

NOTES:

1. WHEN THE MINIMUM LANE WIDTH OF 10 FT. CANNOT BE MAINTAINED DUE TO A SHOULDER CLOSURE, USE THE DETAIL FOR SHORT OR INTERMEDIATE TERM STATIONARY FLAGGING OPERATION.
2. NO WORK ACTIVITY OR STORAGE OF EQUIPMENT, VEHICLES, OR MATERIAL SHOULD OCCUR WITHIN A BUFFER SPACE.
3. WHEN THE DISTANCE BETWEEN THE ADVANCE WARNING SIGNS AND WORK IS 2 MILES TO 5 MILES, A SUPPLEMENTAL DISTANCE PLAQUE (W7-3a) SHOULD BE USED WITH THE SHOULDER WORK SIGN (W21-5).
4. THE ROAD WORK NEXT XX MILES SIGN (G20-1) MAY BE USED INSTEAD OF THE ROAD WORK AHEAD SIGN (W20-1) IF LOCATIONS OCCUR OVER A DISTANCE OF MORE THAN 2 MILES.
5. FOR BARRIER VEHICLE USE REQUIREMENTS SEE TABLES NY1-A AND NY2-A ON THE LEGEND AND TABLES DRAWING (M619-11).
6. IN SITUATIONS WHERE MULTIPLE WORK LOCATIONS EXIST WITHIN A LIMITED DISTANCE, THE DISTANCE BETWEEN THE ADVANCE WARNING SIGN AND WORK SHALL NOT EXCEED 5 MILES.
7. CHANNELIZING DEVICE SPACING (CENTER TO CENTER) SHALL NOT EXCEED 40 FT. IN THE ACTIVE WORK SPACE.
8. TRANSVERSE DEVICES SHALL BE REQUIRED (AS PER 619 STANDARD SPECIFICATIONS) WHEN A PAVED SHOULDER HAVING A WIDTH OF 8 FT. OR GREATER IS CLOSED FOR A DISTANCE GREATER THAN 1500 FT.

NOTES:

1. WHEN PAVED SHOULDERS HAVING A WIDTH OF 8FT. OR MORE ARE CLOSED, CHANNELIZING DEVICES SHALL BE USED TO CLOSE THE SHOULDER IN ADVANCE TO DELINEATE THE BEGINNING OF THE WORK AREA AND DIRECT VEHICULAR TRAFFIC TO REMAIN IN THE TRAVEL WAY.
2. WHEN A SIDE ROAD OR DRIVEWAY INTERSECTS THE ROADWAY WITHIN A WORK ZONE TRAFFIC CONTROL AREA, ADDITIONAL TEMPORARY TRAFFIC CONTROL DEVICES AND/OR FLAGGER SHALL BE PLACED AS NEEDED. ADDITIONAL FLAGGERS SHALL BE LOCATED AT ALL INTERSECTIONS AND COMMERCIAL DRIVEWAYS LOCATED WITHIN OR NEAR THE ACTIVE WORK SPACE.
3. NO WORK ACTIVITY, EQUIPMENT, OR STORAGE OF VEHICLES, OR MATERIAL SHALL OCCUR WITHIN THE BUFFER SPACE AT ANY TIME.
4. CHANNELIZING DEVICE SPACING (CENTER TO CENTER) SHALL NOT EXCEED 40FT. IN THE ACTIVE WORK SPACE.
5. TRANSVERSE DEVICES SHALL BE REQUIRED (AS PER 619 STANDARD SPECIFICATIONS) WHEN A PAVED SHOULDER HAVING A WIDTH OF 8FT. OR GREATER IS CLOSED FOR A DISTANCE GREATER THAN 1500FT.
6. THE END ROAD WORK SIGN (G20-2) SHALL BE PLACED A MAXIMUM OF 500FT. PAST THE END OF THE WORK SPACE.
7. WHERE DIRECTED BY THE ENGINEER, A BUFFER SPACE SHALL BE PROVIDED IN ORDER TO LOCATE THE ONE-LANE, TWO-WAY TRAFFIC TAPER PRIOR TO ANY HORIZONTAL OR VERTICAL CURVE, IN ORDER TO PROVIDE ADEQUATE SIGHT DISTANCE FOR THE FLAGGERS AND/OR A QUEUE OF STOPPED VEHICLES.
8. THE FLAG TREE SHALL BE LOCATED ON THE SHOULDER, AT APPROXIMATELY 1/2 THE DISTANCE BETWEEN THE FLAGGER SIGN (W20-7a) AND THE FLAGGER.
9. FLAGGER SIGN (W20-7a) AND ONE LANE ROAD AHEAD SIGN (W20-4) SHALL BE REMOVED, COVERED OR TURNED AWAY FROM ROAD USERS WHEN FLAGGING OPERATIONS ARE NOT OCCURRING.
10. FLAGGER AND FLAG TREE SHALL BE ILLUMINATED TO LEVEL II ILLUMINATION DURING NIGHT TIME OPERATIONS.
11. ALL FLAGGERS SHALL USE 24 INCH (MIN.) OCTAGON SHAPED STOP/SLOW PADDLES HAVING 6FT. STAFF.
12. CENTERLINE CHANNELIZING DEVICES ARE OPTIONAL AND MAY BE ELIMINATED WHERE SPACE CONSTRAINTS EXIST.

Greenman-Pedersen, Inc.
Engineering and Construction Services

In Western New York:
ROCHESTER (865) 466-4659
JAMESTOWN (716) 469-2603

IN BUFFALO:
BUFFALO (716) 633-4844



SCALE: NONE	DRAWN BY: SID	CHECKED BY: GEB	DATE: AUG 2019
DWG NO.: 7	JOB NO.:	DATE:	DATE:
NO.	NO.	NO.	NO.

WORK ZONE TRAFFIC CONTROL
CATTARAUGUS DEPARTMENT OF PUBLIC WORKS
2020 BRIDGE PAINTING PROJECT
VARIOUS LOCATIONS IN CATTARAUGUS COUNTY