

---

# PROPOSAL

---

P.I.N 5757.33  
FA PROJECT

Submitted in accordance with the Highway Law and the NYSDOT Standard Specifications officially finalized and adopted on September 1, 2019.

Replacement of New Albion Bridge #35  
(B.I.N. 3322810) Tannery Street Bridge over  
Tributary South Branch Cattaraugus Creek

LETTING TIME & DATE:  
October 23, 2019 at 2:00 PM

LETTING LOCATION:  
CATTARAUGUS COUNTY DEPARTMENT OF  
PUBLIC WORKS FACILITY  
8810 ROUTE 242  
LITTLE VALLEY, NY 14755



VILLAGE OF CATTARAUGUS, TOWN OF NEW ALBION,  
CATTARAUGUS COUNTY



## IMPORTANT BIDDER INFORMATION

The pages in this proposal are numbered consecutively. In the event that any pages are missing or are illegible, a replacement copy shall be furnished free of charge upon request. The pages in the plans are also lettered or numbered. In the event that any pages are missing or illegible, a replacement copy shall be furnished free of charge upon request.

This is a federally-aided contract subject to the approval of the New York State Department of Transportation (NYSDOT). Whenever municipal contract terms and requirements differ from federal requirements, the federal requirements will prevail.

- 1. Before You Hand in Your Bid, Double Check Your Computations.** Make sure the figures reflect the intent, and check decimal points. Enter a numeric figure for every unit price, and an extension in the total amount bid column.
- 2. Make Sure You Have Bid on All Items.** If it is your intent to bid "0", use numeric and written symbols. Leaving blank spaces can render your bid informal. See §102-05 PROPOSAL SUBMISSION, of the Standard Specifications.
- 3. Make Sure You Sign the Bid.** See §102-05 PROPOSAL SUBMISSION, of the Standard Specifications.
- 4. Eligibility to bid on this contract is not subject to residence or geographic restrictions.**
- 5. Amendments to the Bid Documents during the bid period shall be provided to all plan holders of record (plan holders of record are those entities that have obtained at least one copy of the Bid Documents) in accordance with section §102-05 PROPOSAL SUBMISSION of the Standard Specifications.** All plan holders of record shall provide contact information to which amendments are to be sent (contact information shall include contact person's name, firm's name, firm's address, firm's phone number, e-mail address, etc.). Said contact information shall be provided to the engineer and owner, in writing, within 24 hours of receipt of Contract Documents.
- 6. If Federal Davis-Bacon wage rates differ from New York State prevailing wage rates, then the higher of the two rates shall be paid.**
- 7. Familiarize Yourself with NYSDOT's Standard Specifications.** These may be accessed at <https://www.dot.ny.gov/main/business-center/engineering/specifications/busi-e-standards-usc>.
- 8. Procurement Lobbying Law.** <https://www.dot.ny.gov/main/business-center/contractors/contractors-repository/lobbylaw.pdf>. NYS Finance Law restricts communication with Sponsor personnel on procurements and contact can only be made with designated persons. Contact with non-designated persons or other involved Agencies will be considered a serious matter and may result in disqualification. Contacts are: for technical questions, the Responsible Local Official (RLO) or his/her designate.
- 9. DBE Goals.** <https://www.dot.ny.gov/dotapp/ebo>. This contract is federally funded and has a DBE goal of 9%. You must document your good faith efforts to obtain DBE participation. Solicitation of DBEs must begin

prior to the submission of your bid. For projects with goals, the Pre-Award Utilization Package must be submitted to the RLPL within 7 calendar days after Letting, in accordance with Specifications §102-12 *D/M/WBE Utilization*, using the current version of NYSDOT's approved Civil Rights reporting software.

**10. Bonds.** Statutes require that a low bidder file both a Performance Bond and a Labor and Material Bond for the full amount of the contract. Arrangements should be made with a Surety prior to submitting a bid. Failure to secure bonding could result in the loss of your bid deposit. See NYSDOT Standard Specifications §103-03 *Contract Bonds*.

**11. Bid Security.** Every bid must be accompanied by a bid bond, certified check or bank cashier's check payable to the Sponsor. In the amount of 5% of the total bid.

**12. Business Support Services Available for DBEs.** NYSDOT's Office of Civil Rights (OCR) administers programs that provide technical and business assistance to NYSCUP-certified DBEs. For more information visit <https://www.dot.ny.gov/main/business-center/civil-rights/dbe-ojt>

**13. Do Not Alter the Bid Proposal Unless Directed to Do So by Amendment.** Unauthorized alterations could lead to your being declared Informal. See NYSDOT Standard Specifications §102-05 *Proposal Submission*.

**14. The Contractor is responsible for ensuring that all Amendments have been incorporated into its bid. Bid on All Items and Sign the Bid.** If it is your intent to bid "0", use the numeric symbol. Leaving blank spaces can render your bid informal. See NYSDOT Standard Specifications §102-05 *Proposal Submission*.

**15. Bids Should Be Submitted to the Sponsor in a Sealed Envelope prominently labeled "BID ENCLOSED" and addressed to the Sponsor with, The Company Name, Street Address, Federal Identification Number, Project Number and Project Description Should Be Clearly Marked.** Your Federal Identification Number on the envelope should be the same number used to obtain plans.

**16. Cattaraugus County Local Law 12-2012 as amended by Local Law 5-2015 requires that the County provide a copy of the Cattaraugus County Vendor Responsibility Form to the low bidder.** The low bidder will have 5 business days to return the completed form unless the form was mailed by the county to the vendor, in which case they will have 10 business days from the date of the mailing to return the form. Failure by the low bidder to submit the form within the above time frame will lead to the automatic rejection of their bid. The contractor must also ensure that all subcontractors who contract to work on the Project for consideration in the amount of \$35,000 or greater, complete this form and submit it to the County for approval within 5 days of the preconstruction meeting. The contractor must also submit, in writing, a request for waiver for any subcontractors whose contract is for less than \$35,000. Failure to do so may lead to the rejection of the subcontractor at the County's discretion.

Currently the Commissioner of Public Works has approved the CCA-2 (New York State Vendor Responsibility Questionnaire For-Profit Construction) with attachments A, B, and C to serve as the Cattaraugus County Vendor Responsibility Form. Questionnaires are available at <https://www.dot.ny.gov/bids-and-lettings/construction-contractors/general-info> or can be obtained by calling (518) 457-1564. Contact the Responsible Local Official (RLO) if a reasonable accommodation is needed to participate in the Letting.

# CATTARAUGUS COUNTY

## DEPARTMENT OF PUBLIC WORKS

*Development – Progress – Workmanship*

*Kathleen M. Ellis, Commissioner*

*Devin M. Blue, Deputy Commissioner*

*Mark C. Burr, PE, Director of Engineering*



*8810 Route 242, Jack Ellis Drive*

*Little Valley, New York 14755*

*Phone (716) 938 9121 | Fax (716) 938 2754*

### ADVERTISEMENT FOR BIDS

Sealed bids for **Replacement of New Albion Bridge #35 (B.I.N. 3322810), Tannery Street over Tributary South Branch Cattaraugus Creek**, according to specifications, will be received by the undersigned, at the Department of Public Works Facility, 8810 Route 242, Little Valley, New York, until **Wednesday, October 23, 2019 at 1:45 P.M.** after which they will be publicly opened at **2:00 P.M.** (at the *same location*), by the undersigned, under the direction of the Public Works Committee of the Cattaraugus County Legislature. Each bid, at the time it is received, will be stamped showing date and time of receipt. All bids must be sealed and clearly marked as follows: (Any bid not clearly marked will not be considered.)

#### **DPW BID #67 - Replacement of New Albion Bridge #35 (B.I.N. 3322810), Tannery Street over Tributary South Branch Cattaraugus Creek**

Due to the existing soil conditions and the structure being proposed, a Mandatory Pre-Bid Meeting will be held on **Thursday, October 10, 2019, 10:00 A.M.** The meeting will be held at the Cattaraugus County Department of Public Works, 8810 Route 242, Little Valley, NY 14755. The meeting is mandatory for all prime contractors that will be submitting bids for the project. Subcontractors may attend the meeting. Bids will not be accepted from bidders who did not attend the meeting.

Final Request for Information shall be submitted by 2:30 P.M. **Friday, October 11, 2019.** Issuance of a final addendum shall be on or before **Wednesday, October 16, 2019** at 3:00 P.M.

Electronic copies are available at no cost and can be obtained by contacting Dawn Smith at 938-9121, ext. 2465. Questions and RFI's to be directed to Bill Fox, PE, 716-938-9121 ext. 2439 or [wafax@cattco.org](mailto:wafax@cattco.org). The specifications for this project will be available for examination at the Department of Public Works; 8810 Route 242, Little Valley, NY 14755, (716) 938-9121, ext. 2465; Stantec Consulting Services, Inc.; 61 Commercial Street, Suite 100, Rochester, NY 14614-1009; (585) 475-1440 and Southern Tier Builders Association, 65 West Main St., Falconer, NY 14733, & on their web site, (STBA website at: <https://bxstier.com/>) Login Page: <http://login.onlineplanservice.com/SP/code.aspx> Password: **NYBX19-04026-67**

Cattaraugus County Local Law 12-2012 as amended by Local Law 5-2015 requires that the County provide a copy of the Cattaraugus County Vendor Responsibility Form to the low bidder. The low bidder will have 5 business days to return the completed form unless the form was mailed by the county to the vendor, in which case they will have 10 business days from the date of the mailing to return the form. Failure by the low bidder to submit the form within the above time frame will lead to the automatic rejection of their bid. The contractor must also ensure that all subcontractors who contract to work on the Project for consideration in the amount of \$35,000 or greater, complete this form and submit it to the County for approval within 5 days of the preconstruction meeting. The contractor must also submit, in writing, a request for waiver for any subcontractors whose contract is for less than \$35,000. Failure to do so may lead to the rejection of the subcontractor at the County's discretion.

Currently the Commissioner of Public Works has approved the CCA-2 (New York State Vendor Responsibility Questionnaire For-Profit Construction) with attachments A, B, and C to serve as the Cattaraugus County Vendor Responsibility Form.

**All bids must be sent or delivered to Cattaraugus County Department of Public Works, 8810 Route 242, Little Valley, NY 14755. Attention: Dawn Smith.**

All bids must be accompanied by a NON-COLLUSIVE BIDDING CERTIFICATE and Bid Bond in the amount of 5% of bid total. All substitutions are to be submitted at time of bid as per the contract documents. No substitutions will be considered after the bid date. Any bid submitted without such certification and bid bond will not be accepted. Any bid not meeting ALL specifications will not be considered. Cattaraugus County reserves the right to reject any or all bids, to waive any informalities, and to accept the lowest responsible bid.

This project has a DISADVANTAGED BUSINESS ENTERPRISE (DBE) utilization goal of 9%.

Equal Opportunity Employment (EEO) Goals:

This Project has a MINORITY PARTICIPATION EEO goal of 6.3%.

This Project has a FEMALE PARTICIPATION EEO goal of 6.9%.

Cattaraugus County and the New York State Department of Transportation, in accordance with Title VI of the Civil Rights Act of 1964, 78 Stat. 252, 42 U.S.C. 2000d to 2000d-4 and Title 49, Code of Federal Regulations, Department of Transportation, Subtitle A, Office of the Secretary, Part 21, Nondiscrimination in Federally-assisted programs of the Department of Transportation and Title 23 Code of Federal Regulations, Part 200, Title Vi Program and Regulated Statutes, as amended, issued pursuant to such Act, hereby notifies all who respond to a written Department solicitation, request for proposal or invitation for bid that it will affirmatively insure that in any contract entered into pursuant to this advertisement, disadvantaged business enterprises will be afforded full opportunity to submit bids in response to this invitation and will not be discriminated against on the grounds of race, color, national origin, sex, age, disability/handicap and income status in consideration for an award.

John Searles  
County Administrator  
County Center - 303 Court Street  
Little Valley, New York 14755

# TABLE OF CONTENTS

<b>PROPOSAL SECTION</b>	<b>PAGE NO.</b>
<b><i>PROJECT TITLE SHEET (With Uniform Contracting Questionnaire Note)</i></b>	7
<b><i>SECTION 1 - RETURN WITH BID DOCUMENTS</i></b>	9
BID DEPOSIT	11
ITEMIZED PROPOSAL	13
REQUIREMENTS REGARDING LOBBYING ACTIVITIES	39
NON-COLLUSIVE BIDDING CERTIFICATIONS	44
REPORTING VIOLATIONS OF NON-COLLUSIVE BIDDING PROCEDURES, MISCONDUCT, ETC.	51
DBE REQUIREMENTS and DBE GOALS	52
BID BOND	53
BIDDER INFORMATION SHEET	57
<b><i>SECTION 2 - REQUIRED CONTRACT PROVISIONS</i></b>	59
EQUAL EMPLOYMENT OPPORTUNITY REQUIREMENTS	61
GOALS FOR MINORITY PARTICIPATION IN THE CONSTRUCTION INDUSTRY	62
SUPPLEMENTAL TITLE VI PROVISIONS (CIVIL RIGHTS ACT)	63
REQUIRED CONTRACT PROVISIONS FOR FEDERAL AID PROJECTS	64
REFERENCE SHEET	84
LOCAL LAW NUMBER 12-2012 AMENDED BY LOCAL LAW NUMBER 5-2015 COUNTY OF CATTARAUGUS, NEW YORK	86
IRAN DIVESTMENT ACT	89
AFFIDAVIT OF COMPLIANCE AND RECEIPT OF PREVAILING WAGE SCHEDULE	91
<b><i>SECTION 3 – SUPPLEMENTAL INFORMATION</i></b>	93
65CONR 9 (3/11) – SUPPLEMENTAL INFORMATION AVAILABLE TO BIDDERS	95
SIGN FACE LAYOUTS	97
EARTHWORK SUMMARY SHEETS	101
SUBSURFACE INVESTIGATION BORING LOGS	105
NYSDEC WATER QUALITY CERTIFICATION LETTER	127
USACE PERMIT	131
<b><i>SECTION 4 – DEFINITIONS AND TERMS</i></b>	189
<b><i>SECTION 5 - SPECIAL NOTES</i></b>	193

## TABLE OF CONTENTS CONT.

<b><i>SECTION 6 - SPECIAL SPECIFICATIONS &amp; REVISIONS TO STANDARD SPECIFICATIONS</i></b>	217
<b><i>SECTION 7 - PREVAILING WAGE RATES</i></b>	231
<b><i>SECTION 8 – SPONSOR CONTRACT AGREEMENT</i></b>	339



# PROJECT TITLE SHEET

COUNTY: Cattaraugus

## PROJECT DESCRIPTION:

Replacement of the existing single-span bridge that carries New Albion Bridge #35 (B.I.N. 3322810) Tannery Street over Tributary South Branch Cattaraugus Creek in the Village of Cattaraugus and Town of New Albion, Cattaraugus County.

Construction efforts will include removal of the existing bridge and replacement with a new bridge. The new bridge will consist of a single span precast concrete three-side structure on a stepped mat foundation. The bridge will be constructed on a horizontal alignment similar to the existing and a profile approximately two feet higher than the existing at the bridge.

The approach roadway will be reconstructed at each end of the bridge from approximately 210 feet north of the bridge to approximately 260 feet south of the new bridge. Additional work will include drainage system improvements, signage improvements, installation of stone fill slope protection, construction of a stream plunge pool and bioretention facilities, and replacement of guide railing throughout the project corridor.

CAPITAL PROJECT IDENTIFICATION NUMBER (P.I.N.): 5757.33

DEPOSIT REQUIRED: 5% of total bid (Certified check, bank cashier's check made payable to "Cattaraugus County Treasurer") or bid bond in the amount of 5% of total bid.

COMPLETION DATE: All work shall be completed on or before October 31, 2020 or 160 days after the commencement of in-stream work, whichever is earlier.

SPONSOR CONTACT (for non-technical project questions or comments):  
Bill Fox, P.E., Sr. Civil Engineer, (716) 938-9121

DESIGNER CONTACT (for project-related technical questions):  
Thomas R. Butler, Project Manager, (585) 475-1440

BIDDERS ARE HEREBY ADVISED THAT THE SPONSOR MAY EXERCISE ITS RIGHTS TO REJECT ANY PROPOSAL, PURSUANT TO SECTION 103-01 OF THE STANDARD SPECIFICATIONS, IN WHICH BID PRICES APPEAR IN THE SPONSOR'S JUDGEMENT TO CONSTITUTE AN UNBALANCED BID FOR THE WORK.

UPON BEING IDENTIFIED AS THE APPARENT LOW BIDDER, A COMPLETED NEW YORK STATE UNIFORM CONTRACTING QUESTIONNAIRE (NYSUCQ) CCA-2 FORM MUST BE FILED AND APPROVED PRIOR TO THE AWARD OF A CONTRACT OR APPROVAL TO SUBCONTRACT. THE QUESTIONNAIRE WILL GENERALLY COVER ALL LOW BIDS OR SUBCONTRACT REQUESTS FOR ONE CALENDAR YEAR. QUESTIONNAIRES CAN BE OBTAINED AT THE WEBSITE BELOW.

<https://www.dot.ny.gov/bids-and-lettings/construction-contractors/general-info>

**This Page Left Intentionally Blank**

## Section 1

<b>RETURN WITH BID DOCUMENTS</b>
----------------------------------

BID DEPOSIT

---

BID SHEETS

---

ITEMIZED PROPOSAL

---

CERTIFICATION FOR FEDERAL AID CONTRACTS

---

REQUIREMENTS REGARDING LOBBYING ACTIVITIES

---

NON-COLLUSIVE BIDDING CERTIFICATIONS

---

NON-COLLUSIVE BIDDING CERTIFICATION BIDDER INFORMATION

---

REPORTING VIOLATIONS OF NON-COLLUSIVE BIDDING PROCEDURES, MISCONDUCT,  
ETC.

---

DBE REQUIREMENTS and DBE GOALS

---

BID BOND

---

BIDDER INFORMATION

---

---

---

---

---

---

---

---

---

---

*NOTE: This form was developed for repetitive use throughout all contract proposals and may identify items not applicable to this specific project.*

**This Page Left Intentionally Blank**

## **BID DEPOSIT**

Accompanying this proposal is a bid bond, certified check or bank cashier's check for the specified amount of deposit required. In the event this proposal is accepted and the undersigned shall fail to execute the contract and in all respects comply with the provisions of Section 38 of the Highway Law, as amended, or where applicable, Section 30 of the Canal Law, as amended, the moneys represented by such bid bond, certified check or bank cashier's check shall be regarded as liquidated damages and shall be forfeited and become the property of the owner; otherwise to be returned to the depositor in accordance with the provisions of said Section 38 of the Highway Law, as amended, or where applicable with Section 30 of the Canal Law, as amended.

On acceptance of this proposal for said work the undersigned does or do hereby bind herself/himself or itself/themselves to enter into written contract, within ten days of date of notice of award, with the said owner, and to comply in all respects with §38(6) of the Highway Law, as amended, or where applicable with §30(7) of the Canal Law, as amended, in relation to security for the faithful performance of the terms of said contract.

F.A. Project

Capital Project Identification Number (P.I.N.): 5757.33

Deposit Required: Certified Check or Bank Cashier's Check for 5% of the Total Bid, or Bid Bond for 5% of the Total Bid, made payable to "Cattaraugus County Treasurer".

**This Page Left Intentionally Blank**

**BID FORMS OMITTED FROM  
SPECIFICATION BOOKS**

TO OBTAIN BID FORMS PLEASE CONTACT

DAWN SMITH AT 716-938-9121 EXT. 2465

OR SEND EMAIL REQUEST TO:

**[dasmith@cattco.org](mailto:dasmith@cattco.org)**

**This Page Left Intentionally Blank**



**JURAT**

**ITEMIZED PROPOSAL**

In submitting this bid, the undersigned declares that he/she is or they are the only person or persons interested in the bid; that it is made without any connection with any person making another bid for the same contract; that the bid is in all respects fair and without collusion, fraud or mental reservation; and that no official of the County or any person in the employ of the County is directly or indirectly interested in the bid or in the supplies or work to which it relates, or in any portion of the profits thereof.

The undersigned also declares that he/she has or they have carefully examined the plans, specifications and form of contract, and that he has or they have personally inspected the actual location of the work, together with the local sources of supply, has or have satisfied himself or themselves as to all the full scope of the work and existing conditions, and understands that in signing this proposal, he/she or they waive all rights to plead any misunderstandings regarding the same. The Contractor at his own expense may elect to obtain additional information at the site, such as deep holes or borings; however, he/she must inform the County three days prior to such explorations.

The undersigned further understands and agrees that he/she is or they are to furnish and provide for the respective work, all the necessary materials, machinery, implements, tools, labor, services and other items of whatever nature, and to do and perform all work necessary under the aforesaid conditions; to complete the improvement of the aforementioned project in accordance with the plans and the specifications for such improvement, which plans and specifications it is agreed are a part of this proposal.

The undersigned further agrees to accept the aforesaid Itemized Bid as compensation for the completion of the project as detailed in the contract documents.

Dated: \_\_\_\_\_, 20\_\_\_\_\_

\_\_\_\_\_  
Legal Name of Person, Firm or Corporation

By: \_\_\_\_\_  
Must be Signed in Ink

**JURAT**

The undersigned further acknowledges receipt of the following addenda to the subject project (if none, state "NONE"):

Addendum No. \_\_\_\_\_ Dated \_\_\_\_\_

Addendum No. \_\_\_\_\_ Dated \_\_\_\_\_

Addendum No. \_\_\_\_\_ Dated \_\_\_\_\_

Receipt is hereby acknowledged for all addenda listed above.

Signature of Bidder \_\_\_\_\_

Date \_\_\_\_\_

## **JURAT**

### **CERTIFICATION FOR FEDERAL AID CONTRACTS**

The prospective participant certifies, by signing and submitting this bid or proposal, to the best of his/her knowledge and belief, that:

1. No Federal appropriated funds have been paid or will be paid, by or on behalf of the undersigned, to any person for influencing or attempting to influence an officer or employee of any Federal agency, a Member of Congress, an officer or employee of Congress, or an employee of a Member of Congress, in connection with the awarding of any Federal contract, the making of any Federal grant, the making of any Federal loan, the entering into of any cooperative agreement, and the extension, continuation, renewal, amendment, or modification of any Federal contract, grant, loan, or cooperative agreement.
  
2. If any funds other than Federal appropriated funds have been paid or will be paid to any person for influencing or attempting to influence an officer or employee of any Federal agency, a Member of Congress, an officer or employee of Congress, or an employee of a Member of Congress, in connection with this Federal contract, grant, loan, or cooperative agreement, the undersigned shall complete and submit Standard Form-LLL, "Disclosure Form to Report Lobbying", in accordance with its instructions.

This certification is a material representation of fact upon which reliance was placed when this transaction was made or entered into. Submission of this certification is a prerequisite for making or entering into this transaction imposed by Section 1352, Title 31, U. S. Code. Any person who fails to file the required certification shall be subject to a civil penalty of not less than \$10,000.00 and not more than \$100,000.00 for each such failure.

The prospective participant also agrees by submitting his/her bid or proposal that he/she shall require that the language of this certification be included in all lower tier subcontracts which exceed \$100,000.00 and that such subrecipients shall certify and disclose accordingly.

## INSTRUCTIONS FOR COMPLETION OF SF-LLL, DISCLOSURE OF LOBBYING ACTIVITIES

This disclosure form shall be completed by the reporting entity, whether subawardee or prime Federal recipient, at the initiation or receipt of a covered Federal action, or a material change to a previous filing, pursuant to title 31 U.S.C. section 1352. The filing of a form is required for each payment or agreement to make payment to any lobbying entity for influencing or attempting to influence an officer or employee of any agency, Member of Congress, an officer or employee of Congress, or an employee of a Member of Congress in connection with a covered Federal action. Complete all items that apply for both the initial filing and material change report. Refer to the implementing guidance published by the Office of Management and Budget for additional information.

1. Identify the type of covered Federal action for which lobbying activity is and/or has been secured to influence the outcome of a covered Federal action.
2. Identify the status of the covered Federal action.
3. Identify the appropriate classification of this report. If this is a follow-up report caused by a material change to the information previously reported, enter the year and quarter in which the change occurred. Enter the date of the last previously submitted report by this reporting entity for this covered Federal action.
4. Enter the full name, address, city, state and zip code of the reporting entity. Include Congressional District, if known. Check the appropriate classification of the reporting entity that designates if it is, or expects to be, a prime or subaward recipient. Identify the tier of the subawardee, e.g., the first subawardee of the prime is the 1st tier. Subawards include but are not limited to subcontracts, subgrants, and contract awards under grants.
5. If the organization filing the report in item 4 checks "Subawardee", then enter the full name, address, city, state and zip code of the prime Federal recipient. Include Congressional District, if known.
6. Enter the name of the Federal agency making the award or loan commitment. Include at least one organizational level below agency name, if known. For example, Department of Transportation, United States Coast Guard.
7. Enter the Federal program name or description for the covered Federal action (item 1). If known, enter the full Catalog of Federal Domestic Assistance (CFDA) number for grants, cooperative agreements, loans, and loan commitments.
8. Enter the most appropriate Federal identifying number available for the Federal action identified in item 1 (e.g., Request for Proposal (RFP) number; Invitation for Bid (IFB) number; grant announcement number; the contract, grant, or loan award number; the application/proposal control number assigned by the Federal agency). Include prefixes, e.g., "RFP-DE-90-001".
9. For a covered Federal action where there has been an award or loan commitment by the Federal agency, enter the Federal amount of the award/loan commitment for the prime entity identified in item 4 or 5.
10. (a) Enter the full name, address, city, state and zip code for the lobbying registrant under the Lobbying Disclosure Act of 1995 engaged by the reporting entity identified in item 4 to

influence the Federal covered action.

(b) Enter the full names of the individual(s) performing services, and include full address if different from 10(a). Enter Last Name, First Name, and Middle Initial (MI).

11. The certifying official shall sign and date the form; print his/her name, title, and telephone number.

According to the Paperwork Reduction Act, as amended, no persons are required to respond to a collection of information unless it displays a valid OMB Control Number. The valid OMB Control Number for this information collection is OMB No. 0348-0046. Public reporting burden for this collection of information is estimated to average 10 minutes per response, including time for reviewing instructions, searching existing data sources, gathering and maintaining the data needed, and completing and reviewing the collection of information. Send comments regarding the burden estimate or any other aspect of this collection of information, including suggestions for reducing this burden, to the Office of Management and Budget, Paperwork Reduction Project (0348-0046), Washington D.C. 20503.

## DISCLOSURE OF LOBBYING ACTIVITIES

Complete this form to disclose lobbying activities pursuant to 31 U.S.C. 1352 (See reverse for public burden disclosure.)

<b>1. Type of Federal Action:</b>	<b>2. Status of Federal Action:</b>	<b>3. Report Type:</b>
a. contract	a. bid/offer/application	a. initial filing
b. grant c. cooperative agreement d. loan	b. initial award c. post-award	b. material change <b>For Material Change Only:</b> year _____ quarter _____ date of last report
e. loan guarantee		
f. loan insurance		
<b>4. Name and Address of Reporting Entity:</b> <input type="checkbox"/> Prime <input type="checkbox"/> Subawardee Tier _____, if known:		<b>5. If Reporting Entity in No. 4 is a Subawardee, Enter Name and Address of Prime:</b>
Congressional District, if known:		Congressional District, if known:
<b>6. Federal Department/Agency:</b>	<b>7. Federal Program Name/Description:</b>	
	CFDA Number, if applicable:	
<b>8. Federal Action Number, if known:</b>	<b>9. Award Amount, if known:</b>	
	\$	
<b>10. a. Name and Address of Lobbying Registrant</b> (if individual, last name, first name, MI):	<b>b. Individuals Performing Services</b> (including address if different from No. 10a) (last name, first name, MI):	
<b>11.</b> Information requested through this form is authorized by title 31 U.S.C. section 1352. This disclosure of lobbying activities is a material representation of fact upon which reliance was placed by the tier above when this transaction was made or entered into. This disclosure is required pursuant to 31 U.S.C. 1352. This information will be available for public inspection. Any person who fails to file the required disclosure shall be subject to a civil penalty of not less than \$10,000 and not more than \$100,000 for each such failure.	Signature:	
	Print Name:	
	Title:	
	Telephone No.:	Date:
<b>Federal Use Only:</b>	Authorized for Local Reproduction Standard Form LLL (Rev. 7-97)	

**REQUIREMENTS REGARDING LOBBYING ACTIVITIES ON FEDERAL AID CONTRACTS**

**DISCLOSURE OF LOBBYING ACTIVITIES**

Approved by  
OMB  
0348-0046

Continuation Sheet

Reporting Entity: \_\_\_\_\_ Page \_\_\_\_\_ Of \_\_\_\_\_

Empty reporting area for disclosure of lobbying activities.

Authorized for Local Reproduction - Standard Form LLL

## JURAT

### NON-COLLUSIVE BIDDING CERTIFICATIONS REQUIRED BY SECTION 139-D, STATE FINANCE LAW and SECTION 103-D OF GENERAL MUNICIPAL LAW

"Section 139-d, SFL and Section 103-d, GML, "Statement of non-collusion in bids to the state."

1. Every bid hereafter made to the state or any public department, agency, or official thereof, where competitive bidding is required by statute, rule, or regulation, for work or services performed or to be performed or goods sold or to be sold, shall contain the following statement subscribed by the bidder and affirmed by such bidder as true under the penalties of perjury:

Non-collusive bidding certification.

(a) By submission of this bid, each bidder and each person signing on behalf of any bidder certifies, and in the case of a joint bid, each party thereto certifies as to its own organization, under penalty of perjury, that to the best of his knowledge and belief:

(1) The prices in this bid have been arrived at independently without collusion, consultation, communication, or agreement, for the purpose of restricting competition, as to any matter relating to such prices with any other bidder or with any competitor;

(2) Unless otherwise required by law, the prices which have been quoted in this bid have not been knowingly disclosed by the bidder and will not knowingly be disclosed by the bidder prior to opening, directly or indirectly, to any other bidder or to any competitor; and

(3) No attempt has been made or will be made by the bidder to induce any other person, partnership, or corporation to submit or not to submit a bid for the purpose of restricting competition.

(b) A bid shall not be considered for award nor shall any award be made where (a)(1)(2) and (3) above have not been complied with; provided however, that if in any case the bidder cannot make the foregoing certification, the bidder shall so state and shall furnish with the bid a signed statement which sets forth in detail the reasons therefore. Where (a)(1)(2) and (3) above have not been complied with, the bid shall not be considered for award nor shall any award be made unless the head of the purchasing unit of the state, public department, or agency to which the bid is made, or his designee, determines that such disclosure was not made for the purpose of restricting competition.

The fact that the bidder (a) has published price lists, rates, or tariffs covering items being procured, (b) has informed prospective customers of proposed or pending publication of new or revised price lists for such items or (c) has sold the same items to other customers at the same prices being bid, does not constitute, without more, a disclosure within the meaning of subparagraph one (a).

2. Any bid hereafter made to the state or any public department, agency, or official thereof by a corporate bidder for work or services performed or to be performed or goods sold or to be sold, where competitive bidding is required by statute, rule, or regulation, and where such bid contains the certification referred to in subdivision one of this section, shall be deemed to have been authorized by the board of directors of the bidder and such authorization shall be deemed to have included the signing and submission of the bid and the inclusion therein of the certificate as to non-collusion as the act and deed of the corporation."

(A) 2

"By submission of this bid, the bidder does hereby tender to the Owner this sworn statement



pursuant to Section 1128 of Title 23, U. S. Code-Highways and does hereby certify, in conformance with said Section 112 of Title 23, U. S. Code-Highways that the said Contractor has not, either directly or indirectly, entered into any agreement, participated in any collusion, or otherwise taken any action in restraint of free competitive bidding in connection with the above contract."

**REQUIRED BY TITLE 49, CFR, VOLUME 1, SUBTITLE A, PART 29**

"The signatory to the proposal, being duly sworn, certifies that, EXCEPT AS NOTED BELOW, his/her company and any person associated therewith in the capacity of owner, partner, director, officer, or major stockholder (of five percent or more ownership):

1. Is not currently under suspension, debarment, voluntary exclusion, or determination of ineligibility by any Federal agency;
2. Has not been suspended, debarred, voluntarily excluded, or determined ineligible by any Federal agency within the past three years;
3. Does not have a proposed debarment pending; and
4. Has not been indicted, convicted, or had a civil judgment rendered against it by a court of competent jurisdiction in any matter involving fraud or official misconduct within the past three years.

EXCEPTIONS: The Contractor should list any relevant information, attaching additional sheets to the proposal if necessary. (Exceptions will not necessarily result in disapproval but will be considered in determining responsibility. For any exception noted, the Contractor should indicate to whom it applies, the initiating agency, and the dates of actions. Providing false information may result in criminal prosecution or administrative sanctions).

## Offerer Disclosure of Prior Non-Responsibility Determinations

Name of Individual or Entity Seeking to Enter into the Procurement Contract:

\_\_\_\_\_

Address:

\_\_\_\_\_

\_\_\_\_\_

Name and Title of Person Submitting this Form:

\_\_\_\_\_

\_\_\_\_\_

Contract Procurement Number:

\_\_\_\_\_

Date:

\_\_\_\_\_

1. Has any Governmental Entity made a finding of non-responsibility regarding the individual or entity seeking to enter into the Procurement Contract in the previous four years? (Please circle): No Yes  
If yes, please answer the next questions:

2. Was the basis for the finding of non-responsibility due to a violation of State Finance Law §139-j  
(Please circle): No Yes

3. Was the basis for the finding of non-responsibility due to the intentional provision of false or incomplete information to a Governmental Entity? (Please circle): No Yes

4. If you answered yes to any of the above questions, please provide details regarding the finding of non-responsibility below.

Governmental Entity:

\_\_\_\_\_

Date of Finding of Non-responsibility:

\_\_\_\_\_

Basis of Finding of Non-Responsibility:

\_\_\_\_\_

\_\_\_\_\_

\_\_\_\_\_

(Add additional pages as necessary)

5. Has any Governmental Entity or other governmental agency terminated or withheld a Procurement Contract with the above-named individual or entity due to the intentional provision of false or incomplete information? (Please circle): No Yes

6. If yes, please provide details below.

Governmental Entity:

\_\_\_\_\_

Date of Termination or Withholding of Contract:

\_\_\_\_\_

Basis of Termination or Withholding:

\_\_\_\_\_

\_\_\_\_\_

\_\_\_\_\_

(Add additional pages as necessary)

Offerer certifies that all information provided to the Governmental Entity with respect to State Finance Law §139-k is complete, true and accurate.

By:

\_\_\_\_\_

Signature

Date:

\_\_\_\_\_

Name:

\_\_\_\_\_

Title:

\_\_\_\_\_

**JURAT**

1. NEW YORK STATE FINANCE LAW, ARTICLE 9, SECTION 139-d
2. TITLE 49, CFR, PART 29
3. TITLE 23, U. S. CODE-HIGHWAYS, SECTION 112

THE CONTRACTOR SHOULD CHOOSE THE APPROPRIATE NOTARIZATION WHICH CORRESPONDS TO THE TYPE OF COMPANY (SOLE PROPRIETORSHIP, PARTNERSHIP, OR CORPORATION) THAT HE/SHE REPRESENTS OR IS AFFILIATED WITH. ALL BIDDERS SHOULD FILL OUT THE APPROPRIATE SECTION OF THE BIDDER INFORMATION SHEET.

BY EXECUTING THIS DOCUMENT, THE CONTRACTOR AGREES TO:

1. Perform all work listed in accordance with the Contract Documents at the unit prices bid; subject to the provisions of Section 104 -04, Standard Specifications, Construction and Materials, published by the New York State Department of Transportation, and dated May 4, 2006, if applicable;
2. All the terms and conditions of the non-collusive bidding certifications required by Section 139-d of the State Finance Law, and Section 112, Title 23, U.S. Code;
3. Certification of Specialty Items category selected, if contained in this proposal;
4. Certification of any other clauses required by this proposal and contained herein;
5. Certification, under penalty of perjury, as to the current history regarding suspensions, debarments, voluntary exclusions, determinations of ineligibility, indictments, convictions, or civil judgments required by 49 CFR Part 29.
6. By submission of this bid, each bidder and each person signing on behalf of any bidder certifies, and in the case of a joint bid each party thereto certifies as to its own organization, under penalty of perjury, that the bidder has and has implemented a written policy addressing sexual harassment in the workplace and provides annual sexual harassment training to all of its employees. Such policy shall, at a minimum, meet the requirements of section two hundred one-g of the New York State Labor Law.

Date:

(Legal Name of Person, Corporation, or Firm Which  
is Submitting Bid or Proposal)

BY: \_\_\_\_\_

(Signature of Person Representing Above)

AS: \_\_\_\_\_  
(Official Title of Signator in Above Firm)  
(Acknowledgment by Individual Contractor, If a Corporation)

STATE OF NEW YORK            )  
  ) SS:  
COUNTY OF                    )

On this \_\_\_\_\_ day of \_\_\_\_\_, 20\_\_\_\_, before me  
personally came \_\_\_\_\_, to me known and known  
to me to be the person who executed the above instrument, who being duly sworn by me, did  
depose and say that he/she resides at

\_\_\_\_\_, and that he/she is the  
of the

the corporation described in and which executed the above instrument, and that he/she signed  
his/her name thereto on behalf of said Corporation by order of the Board of Directors of said  
Corporation.

Notary Public

(Acknowledgment by Co-Partnership Contractor)

STATE OF NEW YORK            )  
  ) SS:  
COUNTY OF                    )

On this \_\_\_\_\_ day of \_\_\_\_\_, 20\_\_\_\_, before  
me  
personally came \_\_\_\_\_, to me known and known  
to  
me to be the person described in and who executed the above instrument, who, being duly  
sworn  
by me, did for himself/herself depose and say that he/she is a member of the firm of  
, consisting of himself/ herself and  
, and that he/she executed the foregoing instrument in the firm name of  
and that  
he/she had authority to sign same, and did duly acknowledge to me that he/she executed same  
as  
the act and deed of said firm of \_\_\_\_\_ for the uses  
and  
purposes mentioned herein.

\_\_\_\_\_  
Notary Public

(Acknowledgment by Individual Contractor)

STATE OF NEW YORK                    )  
  ) SS:  
COUNTY OF                            )

On this \_\_\_\_\_ day of \_\_\_\_\_, 20\_\_\_\_\_,  
before me personally came \_\_\_\_\_, to me known and

known to me to be described in and who executed the foregoing instrument, and that he/she  
acknowledged that he/she executed the same.

\_\_\_\_\_  
Notary Public

**NON-COLLUSIVE BIDDING CERTIFICATION BIDDER INFORMATION**

Bidder to provide information listed below:

Bidder Address: \_\_\_\_\_  
Street or P. O. Box No.

\_\_\_\_\_  
City

\_\_\_\_\_  
State ZIP

Federal Identification No.: \_\_\_\_\_

Name of Contact Person: \_\_\_\_\_

Phone # of Contact Person: \_\_\_\_\_

If Bidder is a Corporation:

President's Name & Address:  
\_\_\_\_\_

Secretary's Name & Address:  
\_\_\_\_\_

Treasurer's Name & Address:  
\_\_\_\_\_

If Bidder is a Partnership:

Partner's Name & Address:  
\_\_\_\_\_

Partner's Name & Address:  
\_\_\_\_\_

If Bidder is a Sole Proprietorship:

Owner's Name & Address:  
\_\_\_\_\_

**REPORTING VIOLATIONS OF NON-COLLUSIVE BIDDING PROCEDURES,  
MISCONDUCT, OR OTHER PROHIBITED CONTRACT ACTIVITIES**

U. S. DEPARTMENT OF TRANSPORTATION HOTLINE. Persons with knowledge of bid collusion (i.e., contractors, suppliers, workers, etc.) or other questionable contract related practices (inadequate materials, poor workmanship, theft of materials, etc.) are encouraged to report such activities by calling the U. S. D. O. T. HOTLINE. The HOTLINE number is 1-800-424-9071 and calls will be answered from 8:00 A.M. to 5:00 P.M. EST, Monday thru Friday. This HOTLINE is under the direction of the U.S.D.O.T.'s Inspector General. All information will be treated confidentially and the caller's anonymity will be respected.

NEW YORK STATE INSPECTOR GENERAL HOTLINE. Reports of New York State Governmental Misconduct may be made in strict confidence to the New York State Inspector General on the Toll Free Statewide HOTLINE or by writing to the Office of the Inspector General. The Toll Free Statewide HOTLINE telephone number is 1-800-367-4448 and calls will be answered between 8:00 A.M. and 4:30 P.M., Monday through Friday. The address of the Office of the State Inspector General is the State Capitol, Executive Chamber, Albany, New York 12224.

**NEW YORK STATE DEPARTMENT OF TRANSPORTATION  
DISADVANTAGED BUSINESS ENTERPRISE  
UTILIZATION REQUIREMENTS**

The Department has established the following Disadvantaged Business Enterprise (DBE) utilization goals for this contract. The goal is expressed as a percentage of the total bid price.

Disadvantaged Business Enterprise Utilization Goal     9    %

Information related to the current certification status of Disadvantaged Business Enterprises, can be obtained by contacting the:

NYS Department of Transportation  
Office of Civil Rights  
50 Wolf Road  
POD 6-2  
Albany, NY 12232  
(518) 457-1128 or 457-1129

**Disadvantaged Business Enterprise Officer**

The Bidder shall designate and enter below the name of a Disadvantaged Business Enterprise Officer who will have the responsibility for and must be capable of effectively administering and promoting an active Disadvantaged Business Enterprise Program and who must be assigned adequate authority and responsibility to do so.

Bidder Designated DBE Officer \_\_\_\_\_  
(Name, Title)

Telephone Number \_\_\_\_\_

RETURN THIS PAGE WITH BID

1 OF 1



# BID BOND

KNOW ALL PERSONS BY THESE PRESENTS, that

\_\_\_\_\_  
Proposer) (Name of Contractor /

\_\_\_\_\_  
(Contractor / Proposer Address)  
(hereinafter called the "Principal") and the

\_\_\_\_\_  
a corporation created and existing under the laws of the State of \_\_\_\_\_, having its principal office in the City of \_\_\_\_\_ and authorized as a surety in the State of New York (such surety or Co-sureties are hereinafter called the "Surety"), are held and firmly bound unto Cattaraugus County (hereinafter called the "County"), in the full just sum of [*Five Percent (5%) of Attached Bid /Price Proposal*], good and lawful money of the United States of America, for the payment of which said sum of money, well and truly to be made and done, the said Principal binds themselves (himself/herself, itself), their (his/her, its) heirs, executors and administrators, successors and assigns, and the said Surety binds itself, its successors and assigns jointly and severally, firmly by these presents:

WHEREAS, the said Principal has submitted to the County, a proposal for Replacement of New Albion Bridge #35 (B.I.N. 3322810) Tannery Street Bridge over Tributary South Branch Cattaraugus Creek

(Project Description), and

WHEREAS, under the terms of the Laws of the State of New York as above indicated, the said Principal has filed or intends to file this bond to guarantee that the Principal will execute all required contract proposal documents and furnish such faithful performance or other bonds as may be required by law in accordance with the terms of the Principal's said proposal.

NOW, THEREFORE, the condition of the foregoing obligation is such, that if the said Principal shall promptly execute and submit, and the County shall accept, all required contract proposal documents including such faithful performance bond or other bonds as may be required by law in accordance with the terms of the Principal's said proposal, then this obligation shall be null and void, otherwise to remain in full force and virtue.

In case of multiple or co-sureties, the Co-Sureties agree to empower a single representative with authority to act on behalf of all of the Co-Sureties with respect to this Bond, so that the County will have no obligation to deal with multiple sureties hereunder. All correspondence from the County to the Co-Sureties and all claims under this Bond shall be sent to such designated representative, and all correspondence so sent shall be deemed to have been sent to all Co-Sureties. The Co-Sureties also agree to designate a single agent for service of process with respect to any actions on this Bond, which agent shall either be a natural person or a corporation qualified to act as an agent for service of process under the laws of the State of New York. The designated representative and agent for service of process may be changed only by delivery of written notice (by personal delivery or by certified mail, return receipt requested) to the County designating a single new representative and/or agent, signed by all of the Co-Sureties. The initial representative shall be:

\_\_\_\_\_  
(Name of Representative)

\_\_\_\_\_  
(Address)

\_\_\_\_\_  
(City, State, Zip)

and the initial agent for service of process shall be:

\_\_\_\_\_  
(Name of Initial Agent)

\_\_\_\_\_  
(Address)

\_\_\_\_\_  
(City, State, Zip)

IN TESTIMONY WHEREOF, the said Principal has hereunto set his/her (their, its) hand and the said Surety has caused this instrument to be signed by its authorized officer.

Signed and delivered this \_\_\_\_ day of \_\_\_\_\_ 20\_\_\_\_ in the presence of:

\_\_\_\_\_  
(Company)  
By \_\_\_\_\_ ) Principal  
(Signature)

\_\_\_\_\_  
(Title of Authorized Officer)

\_\_\_\_\_  
(Company)  
By \_\_\_\_\_ ) Surety (or Co-Surety)  
(Signature)

\_\_\_\_\_  
(Title of Authorized Officer)

\_\_\_\_\_  
(Company)  
By \_\_\_\_\_ ) Co-Surety  
(Signature)

\_\_\_\_\_  
(Title of Authorized Officer)

\_\_\_\_\_  
(Company)  
By \_\_\_\_\_ ) Co-Surety  
(Signature)

\_\_\_\_\_  
(Title of Authorized Officer)

(The Surety Company shall append a single copy of a statement of its financial condition and a copy of the resolution authorizing the execution of Bonds by officers of the Company to the bond(s).)

**(Acknowledgment of principal, unless it be a corporation)**

STATE OF NEW YORK ss.:

COUNTY OF \_\_\_\_\_

On this \_\_\_\_ day of \_\_\_\_\_ 20 \_\_\_\_, before me personally came

\_\_\_\_\_  
to me known and known to me to be the person described in and who executed the foregoing instrument and acknowledged that he/she executed the same.

\_\_\_\_\_  
Notary Public

**(Acknowledgment of principal, if a corporation)**

STATE OF NEW YORK ss.:

COUNTY \_\_\_\_\_

On this \_\_\_\_ day of \_\_\_\_\_ 20 \_\_\_\_, before me personally came

\_\_\_\_\_  
to me known and known to me to be the person, who being by me duly sworn, did depose and say that he/she resides in \_\_\_\_\_ that he/she is the \_\_\_\_\_ of \_\_\_\_\_ the corporation described in and which executed the foregoing instrument; and that he/she signed his/her name thereto by order of the Board of Directors of said Corporation.

\_\_\_\_\_  
Notary Public

**(Acknowledgment of Contractor, if a limited liability company)**

STATE OF NEW YORK ss.:

COUNTY OF \_\_\_\_\_

On this \_\_\_\_ day of \_\_\_\_\_ 20 \_\_\_\_, before me personally came

\_\_\_\_\_  
to me known, and known to me to be the person who being duly sworn, did depose and say that he/she resides in \_\_\_\_\_; that he/she is the duly authorized member of the limited liability company described in and which executed the foregoing instrument; and that he/she executed the foregoing instrument on behalf of the limited liability company for the purposes set forth therein as the act and deed of said limited liability company.

\_\_\_\_\_  
Notary Public

**(Acknowledgment of Surety Company)**

STATE OF NEW YORK ss.:

COUNTY OF \_\_\_\_\_

On this \_\_\_\_\_ day of \_\_\_\_\_ 20 \_\_\_\_, before me personally came

\_\_\_\_\_ to me known and known to me to be the person, who being by me duly sworn, did depose and say that

he/she resides in \_\_\_\_\_ that he/she is the \_\_\_\_\_ of \_\_\_\_\_ the corporation described in the foregoing instrument;

and that

he/she signed his/her name thereto by order of the Board of Directors of said Corporation.

\_\_\_\_\_  
Notary Public

**BIDDER INFORMATION SHEET**

NAME OF BIDDER: \* \_\_\_\_\_

ADDRESS: \_\_\_\_\_

PHONE NUMBER: \_\_\_\_\_

TYPE OF ENTITY: CORPORATION \_\_\_\_\_ PARTNERSHIP \_\_\_\_\_ INDIVIDUAL \_\_\_\_\_

IF A NON-PUBLICLY OWNED CORPORATION:

NAME OF CORPORATION: \_\_\_\_\_

LIST OF PRINCIPAL STOCKHOLDERS (HOLDING OVER 5% OF OUTSTANDING SHARES):

\_\_\_\_\_  
\_\_\_\_\_

LIST OF OFFICERS: \_\_\_\_\_

\_\_\_\_\_

LIST OF DIRECTORS: \_\_\_\_\_

\_\_\_\_\_

DATE OF ORGANIZATION: \_\_\_\_\_

IF A PARTNERSHIP:

PARTNERS: \_\_\_\_\_

\_\_\_\_\_

NAME OF PARTNERSHIP:

DATE OF ORGANIZATION: \_\_\_\_\_

\* IF THE BUSINESS IS CONDUCTED UNDER AN ASSUMED NAME, A COPY OF THE CERTIFICATE REQUIRED TO BE FILED UNDER THE NEW YORK GENERAL BUSINESS LAW MUST BE ATTACHED.

**This Page Left Intentionally Blank**



**This Page Left Intentionally Blank**



**EQUAL EMPLOYMENT OPPORTUNITY REQUIREMENTS**

**[SEE SECTION 102-11 OF THE NEW YORK STATE  
DEPARTMENT OF TRANSPORTATION STANDARD SPECIFICATIONS]**

## GOALS FOR MINORITY PARTICIPATION IN THE CONSTRUCTION INDUSTRY

COUNTY	% GOAL	COUNTY	% GOAL	COUNTY	% GOAL
Albany	3.2	Herkimer	2.1	Richmond	*
Allegany	6.3	Jefferson	2.5	Rockland	22.6
Broome	1.1	Kings	*	St. Lawrence	2.5
Bronx	*	Lewis	2.5	Saratoga	3.2
Cattaraugus	6.3	Livingston	5.3	Schenectady	3.2
Cayuga	2.5	Madison	3.8	Schoharie	2.6
Chautauqua	6.3	Monroe	5.3	Schuyler	1.2
Chemung	2.2	Montgomery	3.2	Seneca	5.9
Chenango	1.2	Nassau	5.8	Steuben	1.2
Clinton	2.6	New York	*	Suffolk	5.8
Columbia	2.6	Niagara	7.7	Sullivan	17.0
Cortland	2.5	Oneida	2.1	Tioga	1.1
Delaware	1.2	Onondaga	3.8	Tompkins	1.2
Dutchess	6.4	Ontario	5.3	Ulster	17.0
Erie	7.7	Orange	17.0	Warren	2.6
Essex	2.6	Orleans	5.3	Washington	2.6
Franklin	2.5	Oswego	3.8	Wayne	5.3
Fulton	2.6	Otsego	1.2	Westchester	22.6
Genesee	5.9	Putnam	22.6	Wyoming	6.3
Greene	2.6	Queens	*	Yates	5.9
Hamilton	2.6	Rensselaer	3.2		

\* The following goal ranges are applicable to the indicated trades in the Counties of Bronx, Kings, New York, Queens, and Richmond:

Electricians.....	9.0 to 10.2
Carpenters.....	27.6 to 32.0
Steam Fitters.....	2.2 to 13.5
Metal Lathers.....	26.0 to 28.6
Operating Engineers.....	25.6 to 26.0
Plumbers.....	12.0 to 14.5
Iron Workers (Structural).....	25.9 to 32.0
Elevator Constructors.....	5.5 to 6.5
Bricklayers.....	13.4 to 15.5
Asbestos Workers.....	22.8 to 28.0
Roofers.....	6.3 to 7.5
Iron Workers (Ornamental).....	22.4 to 23.0
Cement Masons.....	23.0 to 27.0
Glaziers.....	16.0 to 20.0
Plasterers.....	15.8 to 18.0
Teamsters.....	22.0 to 22.5
Boilermakers.....	13.0 to 15.5
All Others.....	16.4 to 17.5

### GOALS FOR WOMEN

#### Female Goals - 6.9%

Goals for the utilization of women by Federal and Federally assisted construction contractors were last published on April 7, 1978 (43 CFR 4988, 149000). That April 7, 1978 publication included a 6.9% goal for the period from April 1, 1980 until March 31, 1981. Pursuant to 41 CFR 60-4.6, the 6.9% goal for female utilization is extended until further notice

## SUPPLEMENTAL TITLE VI PROVISIONS (CIVIL RIGHTS ACT)

During the performance of this contract, the contractor, for itself, its assignees and successors in interest (hereinafter referred to as the "contractor") agrees as follows:

(1) Compliance with Regulations: The contractor shall comply with the Regulation relative to nondiscrimination in Federally-assisted programs of the Department of Transportation (hereinafter, "DOT") Title 49, Code of Federal Regulations, Part 21, as they may be amended from time to time, (hereinafter referred to as the Regulations), which are herein incorporated by reference and made a part of this contract.

(2) Nondiscrimination: The Contractor, with regard to the work performed by it during the contract, shall not discriminate on the grounds of race, color, or national origin in the selection and retention of subcontractors, including procurements of materials and leases of equipment. The contractor shall not participate either directly or indirectly in the discrimination prohibited by section 21.5 of the Regulations, including employment practices when the contract covers a program set forth in Appendix B of the Regulations.

(3) Solicitations for Subcontractors, Including Procurements of Materials and Equipment: In all solicitations either by competitive bidding or negotiation made by the contractor for work to be performed under a subcontract, including procurements of materials or leases of equipment, each potential subcontractor or supplier shall be notified by the contractor of the contractor's obligations under this contract and the Regulations relative to nondiscrimination on the grounds of race, color, or national origin.

(4) Information and Reports: The contractor shall provide all information and reports required by the Regulations or directives issued pursuant thereto, and shall permit access to its books, records, accounts, other sources of information, and its facilities as may be determined by the *(Recipient)* or the *(Name of Appropriate Administration)* to be pertinent to ascertain compliance with such Regulations, orders and instructions. Where any information required of a contractor is in the exclusive possession of another who fails or refuses to furnish this information the contractor shall so certify to the *(Recipient)*, or the *(Name of Appropriate Administration)* as appropriate, and shall set forth what efforts it has made to obtain the information.

(5) Sanctions for Noncompliance: In the event of the contractor's noncompliance with the nondiscrimination provisions of this contract, the *(Recipient)* shall impose such contract sanctions as it or the *(Name of Appropriate Administration)* may determine to be appropriate, including, but not limited to:

- (a) withholding of payments to the contractor under the contract until the contractor complies, and/or
- (b) cancellation, termination or suspension of the contract, in whole or in part.

(6) Incorporation of Provisions: The contractor shall include the provisions of paragraphs (1) through (6) in every subcontract, including procurements of materials and leases of equipment; unless exempt by the Regulations, or directives issued pursuant thereto.

The contractor shall take such action with respect to any subcontractor procurement as the *(Recipient)* or the *(Name of Appropriate Administration)* may direct as a means of enforcing such provisions including sanctions for noncompliance: Provided, however, that, in the event a contractor becomes involved in, or is threatened with, litigation with a subcontractor or supplier as a result of such direction, the contractor may request the *(Recipient)* to enter into such litigation to protect the interests of the *(Recipient)*, and, in addition, the contractor may request the United States to enter into such litigation to protect the interests of the United States.

# **REQUIRED CONTRACT PROVISIONS FEDERAL-AID CONSTRUCTION CONTRACTS**

- I. General
- II. Nondiscrimination
- III. Nonsegregated Facilities
- IV. Davis-Bacon and Related Act Provisions
- V. Contract Work Hours and Safety Standards Act Provisions
- VI. Subletting or Assigning the Contract
- VII. Safety: Accident Prevention
- VIII. False Statements Concerning Highway Projects
- IX. Implementation of Clean Air Act and Federal Water Pollution Control Act
- X. Compliance with Governmentwide Suspension and Debarment Requirements
- XI. Certification Regarding Use of Contract Funds for Lobbying

subcontracts and in lower tier subcontracts (excluding subcontracts for design services, purchase orders, rental agreements and other agreements for supplies or services). The design-builder shall be responsible for compliance by any subcontractor, lower-tier subcontractor or service provider.

Contracting agencies may reference Form FHWA-1273 in bid proposal or request for proposal documents, however, the Form FHWA-1273 must be physically incorporated (not referenced) in all contracts, subcontracts and lower-tier subcontracts (excluding purchase orders, rental agreements and other agreements for supplies or services related to a construction contract).

## **ATTACHMENTS**

A. Employment and Materials Preference for Appalachian Development Highway System or Appalachian Local Access Road Contracts (included in Appalachian contracts only)

### **I. GENERAL**

1. Form FHWA-1273 must be physically incorporated in each construction contract funded under Title 23 (excluding emergency contracts solely intended for debris removal). The contractor (or subcontractor) must insert this form in each subcontract and further require its inclusion in all lower tier subcontracts (excluding purchase orders, rental agreements and other agreements for supplies or services).

The applicable requirements of Form FHWA-1273 are incorporated by reference for work done under any purchase order, rental agreement or agreement for other services. The prime contractor shall be responsible for compliance by any subcontractor, lower-tier subcontractor or service provider.

Form FHWA-1273 must be included in all Federal-aid design-build contracts, in all

2. Subject to the applicability criteria noted in the following sections, these contract provisions shall apply to all work performed on the contract by the contractor's own organization and with the assistance of workers under the contractor's immediate superintendence and to all work performed on the contract by piecework, station work, or by subcontract.

3. A breach of any of the stipulations contained in these Required Contract Provisions may be sufficient grounds for withholding of progress payments, withholding of final payment, termination of the contract, suspension / debarment or any other action determined to be appropriate by the contracting agency and FHWA.

4. Selection of Labor: During the performance of this contract, the contractor shall not use convict labor for any purpose within the limits of a construction project on a Federal-aid highway unless it is labor performed by convicts who are on parole, supervised release, or probation. The term Federal-aid highway does not include roadways functionally classified as local roads or rural minor collectors.

## II. NONDISCRIMINATION

The provisions of this section related to 23 CFR Part 230 are applicable to all Federal-aid construction contracts and to all related construction subcontracts of \$10,000 or more. The provisions of 23 CFR Part 230 are not applicable to material supply, engineering, or architectural service contracts.

In addition, the contractor and all subcontractors must comply with the following policies: Executive Order 11246, 41 CFR 60, 29 CFR 1625-1627, Title 23 USC Section 140, the Rehabilitation Act of 1973, as amended (29 USC 794), Title VI of the Civil Rights Act of 1964, as amended, and related regulations including 49 CFR Parts 21, 26 and 27; and 23 CFR Parts 200, 230, and 633.

The contractor and all subcontractors must comply with: the requirements of the Equal Opportunity Clause in 41 CFR 60-1.4(b) and, for all construction contracts exceeding \$10,000, the Standard Federal Equal Employment Opportunity Construction Contract Specifications in 41 CFR 60-4.3.

Note: The U.S. Department of Labor has exclusive authority to determine compliance with Executive Order 11246 and the policies of the Secretary of Labor including 41 CFR 60, and 29 CFR 1625-1627. The contracting agency and the FHWA have the authority and the responsibility to ensure compliance with Title 23 USC Section 140, the Rehabilitation Act of 1973, as amended (29 USC 794), and Title VI of the Civil Rights Act of 1964, as amended, and related regulations including 49 CFR Parts 21, 26 and 27; and 23 CFR Parts 200, 230, and 633.

The following provision is adopted from 23 CFR 230, Appendix A, with appropriate revisions to conform to the U.S. Department of Labor (US DOL) and FHWA requirements.

**1. Equal Employment Opportunity:** Equal employment opportunity (EEO) requirements

not to discriminate and to take affirmative action to assure equal opportunity as set forth under laws, executive orders, rules, regulations (28 CFR 35, 29 CFR 1630, 29 CFR 1625-1627, 41 CFR 60 and 49 CFR 27) and orders of the Secretary of Labor as modified by the provisions prescribed herein, and imposed pursuant to 23 U.S.C. 140 shall constitute the EEO and specific affirmative action standards for the contractor's project activities under this contract. The provisions of the Americans with Disabilities Act of 1990 (42 U.S.C. 12101 et seq.) set forth under 28 CFR 35 and 29 CFR 1630 are incorporated by reference in this contract. In the execution of this contract, the contractor agrees to comply with the following minimum specific requirement activities of EEO:

a. The contractor will work with the contracting agency and the Federal Government to ensure that it has made every good faith effort to provide equal opportunity with respect to all of its terms and conditions of employment and in their review of activities under the contract.

b. The contractor will accept as its operating policy the following statement:

"It is the policy of this Company to assure that applicants are employed, and that employees are treated during employment, without regard to their race, religion, sex, color, national origin, age or disability. Such action shall include: employment, upgrading, demotion, or transfer; recruitment or recruitment advertising; layoff or termination; rates of pay or other forms of compensation; and selection for training, including apprenticeship, pre-apprenticeship, and/or on-the-job training."

**2. EEO Officer:** The contractor will designate and make known to the contracting officers an EEO Officer who will have the responsibility for and must be capable of effectively administering and promoting an active EEO program and who must be assigned adequate authority and responsibility to do so.

**3. Dissemination of Policy:** All members of

the contractor's staff who are authorized to hire, supervise, promote, and discharge employees, or who recommend such action, or who are substantially involved in such action, will be made fully cognizant of, and will implement, the contractor's EEO policy and contractual responsibilities to provide EEO in each grade and classification of employment. To ensure that the above agreement will be met, the following actions will be taken as a minimum:

a. Periodic meetings of supervisory and personnel office employees will be conducted before the start of work and then not less often than once every six months, at which time the contractor's EEO policy and its implementation will be reviewed and explained. The meetings will be conducted by the EEO Officer.

b. All new supervisory or personnel office employees will be given a thorough indoctrination by the EEO Officer, covering all major aspects of the contractor's EEO obligations within thirty days following their reporting for duty with the contractor.

c. All personnel who are engaged in direct recruitment for the project will be instructed by the EEO Officer in the contractor's procedures for locating and hiring minorities and women.

d. Notices and posters setting forth the contractor's EEO policy will be placed in areas readily accessible to employees, applicants for employment and potential employees.

e. The contractor's EEO policy and the procedures to implement such policy will be brought to the attention of employees by means of meetings, employee handbooks, or other appropriate means.

**4. Recruitment:** When advertising for employees, the contractor will include in all advertisements for employees the notation: "An Equal Opportunity Employer." All such advertisements will be placed in publications having a large circulation among minorities

and women in the area from which the project work force would normally be derived.

a. The contractor will, unless precluded by a valid bargaining agreement, conduct systematic and direct recruitment through public and private employee referral sources likely to yield qualified minorities and women. To meet this requirement, the contractor will identify sources of potential minority group employees, and establish with such identified sources procedures whereby minority and women applicants may be referred to the contractor for employment consideration.

b. In the event the contractor has a valid bargaining agreement providing for exclusive hiring hall referrals, the contractor is expected to observe the provisions of that agreement to the extent that the system meets the contractor's compliance with EEO contract provisions. Where implementation of such an agreement has the effect of discriminating against minorities or women, or obligates the contractor to do the same, such implementation violates Federal nondiscrimination provisions.

c. The contractor will encourage its present employees to refer minorities and women as applicants for employment. Information and procedures with regard to referring such applicants will be discussed with employees.

**5. Personnel Actions:** Wages, working conditions, and employee benefits shall be established and administered, and personnel actions of every type, including hiring, upgrading, promotion, transfer, demotion, layoff, and termination, shall be taken without regard to race, color, religion, sex, national origin, age or disability. The following procedures shall be followed:

a. The contractor will conduct periodic inspections of project sites to insure that working conditions and employee facilities do not indicate discriminatory treatment of project site personnel.

b. The contractor will periodically evaluate the spread of wages paid within each

classification to determine any evidence of discriminatory wage practices.

c. The contractor will periodically review selected personnel actions in depth to determine whether there is evidence of discrimination. Where evidence is found, the contractor will promptly take corrective action. If the review indicates that the discrimination may extend beyond the actions reviewed, such corrective action shall include all affected persons.

d. The contractor will promptly investigate all complaints of alleged discrimination made to the contractor in connection with its obligations under this contract, will attempt to resolve such complaints, and will take appropriate corrective action within a reasonable time. If the investigation indicates that the discrimination may affect persons other than the complainant, such corrective action shall include such other persons. Upon completion of each investigation, the contractor will inform every complainant of all of their avenues of appeal.

## **6. Training and Promotion:**

a. The contractor will assist in locating, qualifying, and increasing the skills of minorities and women who are applicants for employment or current employees. Such efforts should be aimed at developing full journey level status employees in the type of trade or job classification involved.

b. Consistent with the contractor's work force requirements and as permissible under Federal and State regulations, the contractor shall make full use of training programs, i.e., apprenticeship, and on-the-job training programs for the geographical area of contract performance. In the event a special provision for training is provided under this contract, this subparagraph will be superseded as indicated in the special provision. The contracting agency may reserve training positions for persons who receive welfare assistance in accordance with 23 U.S.C. 140(a).

c. The contractor will advise employees and applicants for employment of available training programs and entrance requirements for each.

d. The contractor will periodically review the training and promotion potential of employees who are minorities and women and will encourage eligible employees to apply for such training and promotion.

**7. Unions:** If the contractor relies in whole or in part upon unions as a source of employees, the contractor will use good faith efforts to obtain the cooperation of such unions to increase opportunities for minorities and women. Actions by the contractor, either directly or through a contractor's association acting as agent, will include the procedures set forth below:

a. The contractor will use good faith efforts to develop, in cooperation with the unions, joint training programs aimed toward qualifying more minorities and women for membership in the unions and increasing the skills of minorities and women so that they may qualify for higher paying employment.

b. The contractor will use good faith efforts to incorporate an EEO clause into each union agreement to the end that such union will be contractually bound to refer applicants without regard to their race, color, religion, sex, national origin, age or disability.

c. The contractor is to obtain information as to the referral practices and policies of the labor union except that to the extent such information is within the exclusive possession of the labor union and such labor union refuses to furnish such information to the contractor, the contractor shall so certify to the contracting agency and shall set forth what efforts have been made to obtain such information.

d. In the event the union is unable to provide the contractor with a reasonable flow of referrals within the time limit set forth in the collective bargaining agreement, the

contractor will, through independent recruitment efforts, fill the employment vacancies without regard to race, color, religion, sex, national origin, age or disability; making full efforts to obtain qualified and/or qualifiable minorities and women. The failure of a union to provide sufficient referrals (even though it is obligated to provide exclusive referrals under the terms of a collective bargaining agreement) does not relieve the contractor from the requirements of this paragraph. In the event the union referral practice prevents the contractor from meeting the obligations pursuant to Executive Order 11246, as amended, and these special provisions, such contractor shall immediately notify the contracting agency.

**8. Reasonable Accommodation for Applicants / Employees with Disabilities:**

The contractor must be familiar with the requirements for and comply with the Americans with Disabilities Act and all rules and regulations established there under. Employers must provide reasonable accommodation in all employment activities unless to do so would cause an undue hardship.

**9. Selection of Subcontractors, Procurement of Materials and Leasing of Equipment:** The contractor shall not discriminate on the grounds of race, color, religion, sex, national origin, age or disability in the selection and retention of subcontractors, including procurement of materials and leases of equipment. The contractor shall take all necessary and reasonable steps to ensure nondiscrimination in the administration of this contract.

a. The contractor shall notify all potential subcontractors and suppliers and lessors of their EEO obligations under this contract.

b. The contractor will use good faith efforts to ensure subcontractor compliance with their EEO obligations.

**10. Assurance Required by 49 CFR 26.13(b):**

a. The requirements of 49 CFR Part 26 and the State DOT's U.S. DOT-approved DBE program are incorporated by reference.

b. The contractor or subcontractor shall not discriminate on the basis of race, color, national origin, or sex in the performance of this contract. The contractor shall carry out applicable requirements of 49 CFR Part 26 in the award and administration of DOT-assisted contracts. Failure by the contractor to carry out these requirements is a material breach of this contract, which may result in the termination of this contract or such other remedy as the contracting agency deems appropriate.

**11. Records and Reports:** The contractor shall keep such records as necessary to document compliance with the EEO requirements. Such records shall be retained for a period of three years following the date of the final payment to the contractor for all contract work and shall be available at reasonable times and places for inspection by authorized representatives of the contracting agency and the FHWA.

a. The records kept by the contractor shall document the following:

(1) The number and work hours of minority and non-minority group members and women employed in each work classification on the project;

(2) The progress and efforts being made in cooperation with unions, when applicable, to increase employment opportunities for minorities and women; and

(3) The progress and efforts being made in locating, hiring, training, qualifying, and upgrading minorities and women;

b. The contractors and subcontractors will submit an annual report to the contracting agency each July for the duration of the project, indicating the number of minority,



women, and non-minority group employees currently engaged in each work classification required by the contract work. This information is to be reported on [Form FHWA-1391](#). The staffing data should represent the project work force on board in all or any part of the last payroll period preceding the end of July. If on-the-job training is being required by special provision, the contractor will be required to collect and report training data. The employment data should reflect the work force on board during all or any part of the last payroll period preceding the end of July.

### **III. NONSEGREGATED FACILITIES**

This provision is applicable to all Federal-aid construction contracts and to all related construction subcontracts of \$10,000 or more.

The contractor must ensure that facilities provided for employees are provided in such a manner that segregation on the basis of race, color, religion, sex, or national origin cannot result. The contractor may neither require such segregated use by written or oral policies nor tolerate such use by employee custom. The contractor's obligation extends further to ensure that its employees are not assigned to perform their services at any location, under the contractor's control, where the facilities are segregated. The term "facilities" includes waiting rooms, work areas, restaurants and other eating areas, time clocks, restrooms, washrooms, locker rooms, and other storage or dressing areas, parking lots, drinking fountains, recreation or entertainment areas, transportation, and housing provided for employees. The contractor shall provide separate or single-user restrooms and necessary dressing or sleeping areas to assure privacy between sexes.

### **IV. DAVIS-BACON AND RELATED ACT PROVISIONS**

This section is applicable to all Federal-aid construction projects exceeding \$2,000 and to all related subcontracts and lower-tier subcontracts (regardless of subcontract

size). The requirements apply to all projects located within the right-of-way of a roadway that is functionally classified as Federal-aid highway. This excludes roadways functionally classified as local roads or rural minor collectors, which are exempt. Contracting agencies may elect to apply these requirements to other projects.

The following provisions are from the U.S. Department of Labor regulations in 29 CFR 5.5 "Contract provisions and related matters" with minor revisions to conform to the FHWA-1273 format and FHWA program requirements.

#### **1. Minimum wages**

a. All laborers and mechanics employed or working upon the site of the work, will be paid unconditionally and not less often than once a week, and without subsequent deduction or rebate on any account (except such payroll deductions as are permitted by regulations issued by the Secretary of Labor under the Copeland Act (29 CFR part 3)), the full amount of wages and bona fide fringe benefits (or cash equivalents thereof) due at time of payment computed at rates not less than those contained in the wage determination of the Secretary of Labor which is attached hereto and made a part hereof, regardless of any contractual relationship which may be alleged to exist between the contractor and such laborers and mechanics.

Contributions made or costs reasonably anticipated for bona fide fringe benefits under section 1(b)(2) of the Davis-Bacon Act on behalf of laborers or mechanics are considered wages paid to such laborers or mechanics, subject to the provisions of paragraph 1.d. of this section; also, regular contributions made or costs incurred for more than a weekly period (but not less often than quarterly) under plans, funds, or programs which cover the particular weekly period, are deemed to be constructively made or incurred during such weekly period. Such laborers and mechanics shall be paid

the appropriate wage rate and fringe benefits on the wage determination for the classification of work actually performed, without regard to skill, except as provided in 29 CFR 5.5(a)(4). Laborers or mechanics performing work in more than one classification may be compensated at the rate specified for each classification for the time actually worked therein: Provided, That the employer's payroll records accurately set forth the time spent in each classification in which work is performed. The wage determination (including any additional classification and wage rates conformed under paragraph 1.b. of this section) and the Davis-Bacon poster (WH-1321) shall be posted at all times by the contractor and its subcontractors at the site of the work in a prominent and accessible place where it can be easily seen by the workers.

b. (1) The contracting officer shall require that any class of laborers or mechanics, including helpers, which is not listed in the wage determination and which is to be employed under the contract shall be classified in conformance with the wage determination. The contracting officer shall approve an additional classification and wage rate and fringe benefits therefore only when the following criteria have been met:

(i) The work to be performed by the classification requested is not performed by a classification in the wage determination; and

(ii) The classification is utilized in the area by the construction industry; and

(iii) The proposed wage rate, including any bona fide fringe benefits, bears a reasonable relationship to the wage rates contained in the wage determination.

(2) If the contractor and the laborers and mechanics to be employed in the classification (if known), or their representatives, and the contracting officer agree on the classification and wage rate (including the amount designated for fringe

benefits where appropriate), a report of the action taken shall be sent by the contracting officer to the Administrator of the Wage and Hour Division, Employment Standards Administration, U.S. Department of Labor, Washington, DC 20210. The Administrator, or an authorized representative, will approve, modify, or disapprove every additional classification action within 30 days of receipt and so advise the contracting officer or will notify the contracting officer within the 30-day period that additional time is necessary.

(3) In the event the contractor, the laborers or mechanics to be employed in the classification or their representatives, and the contracting officer do not agree on the proposed classification and wage rate (including the amount designated for fringe benefits, where appropriate), the contracting officer shall refer the questions, including the views of all interested parties and the recommendation of the contracting officer, to the Wage and Hour Administrator for determination. The Wage and Hour Administrator, or an authorized representative, will issue a determination within 30 days of receipt and so advise the contracting officer or will notify the contracting officer within the 30-day period that additional time is necessary.

(4) The wage rate (including fringe benefits where appropriate) determined pursuant to paragraphs 1.b.(2) or 1.b.(3) of this section, shall be paid to all workers performing work in the classification under this contract from the first day on which work is performed in the classification.

c. Whenever the minimum wage rate prescribed in the contract for a class of laborers or mechanics includes a fringe benefit which is not expressed as an hourly rate, the contractor shall either pay the benefit as stated in the wage determination or shall pay another bona fide fringe benefit or an hourly cash equivalent thereof.

d. If the contractor does not make payments to a trustee or other third person, the contractor may consider as part of the wages of any laborer or mechanic the amount of any costs reasonably anticipated in providing bona fide fringe benefits under a plan or program, Provided, That the Secretary of Labor has found, upon the written request of the contractor, that the applicable standards of the Davis-Bacon Act have been met. The Secretary of Labor may require the contractor to set aside in a separate account assets for the meeting of obligations under the plan or program.

## **2. Withholding**

The contracting agency shall upon its own action or upon written request of an authorized representative of the Department of Labor, withhold or cause to be withheld from the contractor under this contract, or any other Federal contract with the same prime contractor, or any other federally-assisted contract subject to Davis-Bacon prevailing wage requirements, which is held by the same prime contractor, so much of the accrued payments or advances as may be considered necessary to pay laborers and mechanics, including apprentices, trainees, and helpers, employed by the contractor or any subcontractor the full amount of wages required by the contract. In the event of failure to pay any laborer or mechanic, including any apprentice, trainee, or helper, employed or working on the site of the work, all or part of the wages required by the contract, the contracting agency may, after written notice to the contractor, take such action as may be necessary to cause the suspension of any further payment, advance, or guarantee of funds until such violations have ceased.

## **3. Payrolls and basic records**

a. Payrolls and basic records relating thereto shall be maintained by the contractor during the course of the work and preserved for a period of three years thereafter for all laborers and mechanics working at the site

of the work. Such records shall contain the name, address, and social security number of each such worker, his or her correct classification, hourly rates of wages paid (including rates of contributions or costs anticipated for bona fide fringe benefits or cash equivalents thereof of the types described in section 1(b)(2)(B) of the Davis-Bacon Act), daily and weekly number of hours worked, deductions made and actual wages paid. Whenever the Secretary of Labor has found under 29 CFR 5.5(a)(1)(iv) that the wages of any laborer or mechanic include the amount of any costs reasonably anticipated in providing benefits under a plan or program described in section 1(b)(2)(B) of the Davis-Bacon Act, the contractor shall maintain records which show that the commitment to provide such benefits is enforceable, that the plan or program is financially responsible, and that the plan or program has been communicated in writing to the laborers or mechanics affected, and records which show the costs anticipated or the actual cost incurred in providing such benefits. Contractors employing apprentices or trainees under approved programs shall maintain written evidence of the registration of apprenticeship programs and certification of trainee programs, the registration of the apprentices and trainees, and the ratios and wage rates prescribed in the applicable programs.

b. (1) The contractor shall submit weekly for each week in which any contract work is performed a copy of all payrolls to the contracting agency. The payrolls submitted shall set out accurately and completely all of the information required to be maintained under 29 CFR 5.5(a)(3)(i), except that full social security numbers and home addresses shall not be included on weekly transmittals. Instead the payrolls shall only need to include an individually identifying number for each employee ( e.g. , the last four digits of the employee's social security number). The required weekly payroll information may be submitted in any form desired. Optional Form WH-347 is available for this purpose from the Wage and Hour Division Web site at

<http://www.dol.gov/esa/whd/forms/wh347instr.htm> or its successor site. The prime contractor is responsible for the submission of copies of payrolls by all subcontractors. Contractors and subcontractors shall maintain the full social security number and current address of each covered worker, and shall provide them upon request to the contracting agency for transmission to the State DOT, the FHWA or the Wage and Hour Division of the Department of Labor for purposes of an investigation or audit of compliance with prevailing wage requirements. It is not a violation of this section for a prime contractor to require a subcontractor to provide addresses and social security numbers to the prime contractor for its own records, without weekly submission to the contracting agency..

(2) Each payroll submitted shall be accompanied by a "Statement of Compliance," signed by the contractor or subcontractor or his or her agent who pays or supervises the payment of the persons employed under the contract and shall certify the following:

(i) That the payroll for the payroll period contains the information required to be provided under §5.5 (a)(3)(ii) of Regulations, 29 CFR part 5, the appropriate information is being maintained under §5.5 (a)(3)(i) of Regulations, 29 CFR part 5, and that such information is correct and complete;

(ii) That each laborer or mechanic (including each helper, apprentice, and trainee) employed on the contract during the payroll period has been paid the full weekly wages earned, without rebate, either directly or indirectly, and that no deductions have been made either directly or indirectly from the full wages earned, other than permissible deductions as set forth in Regulations, 29 CFR part 3;

(iii) That each laborer or mechanic has been paid not less than the applicable wage rates and fringe benefits or cash

equivalents for the classification of work performed, as specified in the applicable wage determination incorporated into the contract.

(3) The weekly submission of a properly executed certification set forth on the reverse side of Optional Form WH-347 shall satisfy the requirement for submission of the "Statement of Compliance" required by paragraph 3.b.(2) of this section.

(4) The falsification of any of the above certifications may subject the contractor or subcontractor to civil or criminal prosecution under section 1001 of title 18 and section 231 of title 31 of the United States Code.

c. The contractor or subcontractor shall make the records required under paragraph 3.a. of this section available for inspection, copying, or transcription by authorized representatives of the contracting agency, the State DOT, the FHWA, or the Department of Labor, and shall permit such representatives to interview employees during working hours on the job. If the contractor or subcontractor fails to submit the required records or to make them available, the FHWA may, after written notice to the contractor, the contracting agency or the State DOT, take such action as may be necessary to cause the suspension of any further payment, advance, or guarantee of funds. Furthermore, failure to submit the required records upon request or to make such records available may be grounds for debarment action pursuant to 29 CFR 5.12.

#### **4. Apprentices and trainees**

a. Apprentices (programs of the USDOL).

Apprentices will be permitted to work at less than the predetermined rate for the work they performed when they are employed pursuant to and individually registered in a bona fide apprenticeship program registered with the U.S. Department of Labor, Employment and Training Administration, Office of

Apprenticeship Training, Employer and Labor Services, or with a State Apprenticeship Agency recognized by the Office, or if a person is employed in his or her first 90 days of probationary employment as an apprentice in such an apprenticeship program, who is not individually registered in the program, but who has been certified by the Office of Apprenticeship Training, Employer and Labor Services or a State Apprenticeship Agency (where appropriate) to be eligible for probationary employment as an apprentice.

The allowable ratio of apprentices to journeymen on the job site in any craft classification shall not be greater than the ratio permitted to the contractor as to the entire work force under the registered program. Any worker listed on a payroll at an apprentice wage rate, who is not registered or otherwise employed as stated above, shall be paid not less than the applicable wage rate on the wage determination for the classification of work actually performed. In addition, any apprentice performing work on the job site in excess of the ratio permitted under the registered program shall be paid not less than the applicable wage rate on the wage determination for the work actually performed. Where a contractor is performing construction on a project in a locality other than that in which its program is registered, the ratios and wage rates (expressed in percentages of the journeyman's hourly rate) specified in the contractor's or subcontractor's registered program shall be observed.

Every apprentice must be paid at not less than the rate specified in the registered program for the apprentice's level of progress, expressed as a percentage of the journeymen hourly rate specified in the applicable wage determination. Apprentices shall be paid fringe benefits in accordance with the provisions of the apprenticeship program. If the apprenticeship program does not specify fringe benefits, apprentices must be paid the full amount of fringe benefits listed on the wage determination for the applicable classification. If the Administrator

determines that a different practice prevails for the applicable apprentice classification, fringes shall be paid in accordance with that determination.

In the event the Office of Apprenticeship Training, Employer and Labor Services, or a State Apprenticeship Agency recognized by the Office, withdraws approval of an apprenticeship program, the contractor will no longer be permitted to utilize apprentices at less than the applicable predetermined rate for the work performed until an acceptable program is approved.

b. Trainees (programs of the USDOL).

Except as provided in 29 CFR 5.16, trainees will not be permitted to work at less than the predetermined rate for the work performed unless they are employed pursuant to and individually registered in a program which has received prior approval, evidenced by formal certification by the U.S. Department of Labor, Employment and Training Administration.

The ratio of trainees to journeymen on the job site shall not be greater than permitted under the plan approved by the Employment and Training Administration.

Every trainee must be paid at not less than the rate specified in the approved program for the trainee's level of progress, expressed as a percentage of the journeyman hourly rate specified in the applicable wage determination. Trainees shall be paid fringe benefits in accordance with the provisions of the trainee program. If the trainee program does not mention fringe benefits, trainees shall be paid the full amount of fringe benefits listed on the wage determination unless the Administrator of the Wage and Hour Division determines that there is an apprenticeship program associated with the corresponding journeyman wage rate on the wage determination which provides for less than full fringe benefits for apprentices. Any employee listed on the payroll at a trainee rate who is not registered and participating in

a training plan approved by the Employment and Training Administration shall be paid not less than the applicable wage rate on the wage determination for the classification of work actually performed. In addition, any trainee performing work on the job site in excess of the ratio permitted under the registered program shall be paid not less than the applicable wage rate on the wage determination for the work actually performed.

In the event the Employment and Training Administration withdraws approval of a training program, the contractor will no longer be permitted to utilize trainees at less than the applicable predetermined rate for the work performed until an acceptable program is approved.

c. Equal employment opportunity. The utilization of apprentices, trainees and journeymen under this part shall be in conformity with the equal employment opportunity requirements of Executive Order 11246, as amended, and 29 CFR part 30.

d. Apprentices and Trainees (programs of the U.S. DOT).

Apprentices and trainees working under apprenticeship and skill training programs which have been certified by the Secretary of Transportation as promoting EEO in connection with Federal-aid highway construction programs are not subject to the requirements of paragraph 4 of this Section IV. The straight time hourly wage rates for apprentices and trainees under such programs will be established by the particular programs. The ratio of apprentices and trainees to journeymen shall not be greater than permitted by the terms of the particular program.

**5. Compliance with Copeland Act requirements.** The contractor shall comply with the requirements of 29 CFR part 3, which are incorporated by reference in this contract.

**6. Subcontracts.** The contractor or subcontractor shall insert Form FHWA-1273 in any subcontracts and also require the subcontractors to include Form FHWA-1273 in any lower tier subcontracts. The prime contractor shall be responsible for the compliance by any subcontractor or lower tier subcontractor with all the contract clauses in 29 CFR 5.5.

**7. Contract termination: debarment.** A breach of the contract clauses in 29 CFR 5.5 may be grounds for termination of the contract, and for debarment as a contractor and a subcontractor as provided in 29 CFR 5.12.

**8. Compliance with Davis-Bacon and Related Act requirements.** All rulings and interpretations of the Davis-Bacon and Related Acts contained in 29 CFR parts 1, 3, and 5 are herein incorporated by reference in this contract.

**9. Disputes concerning labor standards.** Disputes arising out of the labor standards provisions of this contract shall not be subject to the general disputes clause of this contract. Such disputes shall be resolved in accordance with the procedures of the Department of Labor set forth in 29 CFR parts 5, 6, and 7. Disputes within the meaning of this clause include disputes between the contractor (or any of its subcontractors) and the contracting agency, the U.S. Department of Labor, or the employees or their representatives.

**10. Certification of eligibility.**

a. By entering into this contract, the contractor certifies that neither it (nor he or she) nor any person or firm who has an interest in the contractor's firm is a person or firm ineligible to be awarded Government contracts by virtue of section 3(a) of the Davis-Bacon Act or 29 CFR 5.12(a)(1).

b. No part of this contract shall be subcontracted to any person or firm ineligible for award of a Government contract by virtue

of section 3(a) of the Davis-Bacon Act or 29 CFR 5.12(a)(1).

c. The penalty for making false statements is prescribed in the U.S. Criminal Code, 18 U.S.C. 1001.

## **V. CONTRACT WORK HOURS AND SAFETY STANDARDS ACT**

The following clauses apply to any Federal-aid construction contract in an amount in excess of \$100,000 and subject to the overtime provisions of the Contract Work Hours and Safety Standards Act. These clauses shall be inserted in addition to the clauses required by 29 CFR 5.5(a) or 29 CFR 4.6. As used in this paragraph, the terms laborers and mechanics include watchmen and guards.

**1. Overtime requirements.** No contractor or subcontractor contracting for any part of the contract work which may require or involve the employment of laborers or mechanics shall require or permit any such laborer or mechanic in any workweek in which he or she is employed on such work to work in excess of forty hours in such workweek unless such laborer or mechanic receives compensation at a rate not less than one and one-half times the basic rate of pay for all hours worked in excess of forty hours in such workweek.

**2. Violation; liability for unpaid wages; liquidated damages.** In the event of any violation of the clause set forth in paragraph (1.) of this section, the contractor and any subcontractor responsible therefor shall be liable for the unpaid wages. In addition, such contractor and subcontractor shall be liable to the United States (in the case of work done under contract for the District of Columbia or a territory, to such District or to such territory), for liquidated damages. Such liquidated damages shall be computed with respect to each individual laborer or mechanic, including watchmen and guards, employed in violation of the clause set forth in paragraph (1.) of this section, in the sum

of \$10 for each calendar day on which such individual was required or permitted to work in excess of the standard workweek of forty hours without payment of the overtime wages required by the clause set forth in paragraph (1.) of this section.

**3. Withholding for unpaid wages and liquidated damages.** The FHWA or the contacting agency shall upon its own action or upon written request of an authorized representative of the Department of Labor withhold or cause to be withheld, from any moneys payable on account of work performed by the contractor or subcontractor under any such contract or any other Federal contract with the same prime contractor, or any other federally-assisted contract subject to the Contract Work Hours and Safety Standards Act, which is held by the same prime contractor, such sums as may be determined to be necessary to satisfy any liabilities of such contractor or subcontractor for unpaid wages and liquidated damages as provided in the clause set forth in paragraph (2.) of this section.

**4. Subcontracts.** The contractor or subcontractor shall insert in any subcontracts the clauses set forth in paragraph (1.) through (4.) of this section and also a clause requiring the subcontractors to include these clauses in any lower tier subcontracts. The prime contractor shall be responsible for compliance by any subcontractor or lower tier subcontractor with the clauses set forth in paragraphs (1.) through (4.) of this section.

## **VI. SUBLETTING OR ASSIGNING THE CONTRACT**

This provision is applicable to all Federal-aid construction contracts on the National Highway System.

1. The contractor shall perform with its own organization contract work amounting to not less than 30 percent (or a greater percentage if specified elsewhere in the contract) of the total original contract price, excluding any specialty items designated by

the contracting agency. Specialty items may be performed by subcontract and the amount of any such specialty items performed may be deducted from the total original contract price before computing the amount of work required to be performed by the contractor's own organization (23 CFR 635.116).

a. The term "perform work with its own organization" refers to workers employed or leased by the prime contractor, and equipment owned or rented by the prime contractor, with or without operators. Such term does not include employees or equipment of a subcontractor or lower tier subcontractor, agents of the prime contractor, or any other assignees. The term may include payments for the costs of hiring leased employees from an employee leasing firm meeting all relevant Federal and State regulatory requirements. Leased employees may only be included in this term if the prime contractor meets all of the following conditions:

(1) the prime contractor maintains control over the supervision of the day-to-day activities of the leased employees;

(2) the prime contractor remains responsible for the quality of the work of the leased employees;

(3) the prime contractor retains all power to accept or exclude individual employees from work on the project; and

(4) the prime contractor remains ultimately responsible for the payment of predetermined minimum wages, the submission of payrolls, statements of compliance and all other Federal regulatory requirements.

b. "Specialty Items" shall be construed to be limited to work that requires highly specialized knowledge, abilities, or equipment not ordinarily available in the type of contracting organizations qualified and expected to bid or propose on the contract as a whole and in general are to be limited to minor components of the overall contract.

2. The contract amount upon which the requirements set forth in paragraph (1) of Section VI is computed includes the cost of material and manufactured products which are to be purchased or produced by the contractor under the contract provisions.

3. The contractor shall furnish (a) a competent superintendent or supervisor who is employed by the firm, has full authority to direct performance of the work in accordance with the contract requirements, and is in charge of all construction operations (regardless of who performs the work) and (b) such other of its own organizational resources (supervision, management, and engineering services) as the contracting officer determines is necessary to assure the performance of the contract.

4. No portion of the contract shall be sublet, assigned or otherwise disposed of except with the written consent of the contracting officer, or authorized representative, and such consent when given shall not be construed to relieve the contractor of any responsibility for the fulfillment of the contract. Written consent will be given only after the contracting agency has assured that each subcontract is evidenced in writing and that it contains all pertinent provisions and requirements of the prime contract.

5. The 30% self-performance requirement of paragraph (1) is not applicable to design-build contracts; however, contracting agencies may establish their own self-performance requirements.

## **VII. SAFETY: ACCIDENT PREVENTION**

This provision is applicable to all Federal-aid construction contracts and to all related subcontracts.

1. In the performance of this contract the contractor shall comply with all applicable Federal, State, and local laws governing safety, health, and sanitation (23 CFR 635). The contractor shall provide all safeguards, safety devices and protective equipment and take any other needed actions as it



determines, or as the contracting officer may determine, to be reasonably necessary to protect the life and health of employees on the job and the safety of the public and to protect property in connection with the performance of the work covered by the contract.

2. It is a condition of this contract, and shall be made a condition of each subcontract, which the contractor enters into pursuant to this contract, that the contractor and any subcontractor shall not permit any employee, in performance of the contract, to work in surroundings or under conditions which are unsanitary, hazardous or dangerous to his/her health or safety, as determined under construction safety and health standards (29 CFR 1926) promulgated by the Secretary of Labor, in accordance with Section 107 of the Contract Work Hours and Safety Standards Act (40 U.S.C. 3704).

3. Pursuant to 29 CFR 1926.3, it is a condition of this contract that the Secretary of Labor or authorized representative thereof, shall have right of entry to any site of contract performance to inspect or investigate the matter of compliance with the construction safety and health standards and to carry out the duties of the Secretary under Section 107 of the Contract Work Hours and Safety Standards Act (40 U.S.C.3704).

#### VIII. FALSE STATEMENTS CONCERNING HIGHWAY PROJECTS

This provision is applicable to all Federal-aid construction contracts and to all related subcontracts.

In order to assure high quality and durable construction in conformity with approved plans and specifications and a high degree of reliability on statements and representations made by engineers, contractors, suppliers, and workers on Federal-aid highway projects, it is essential that all persons concerned with the project perform their functions as carefully, thoroughly, and honestly as possible. Willful falsification, distortion, or misrepresentation with respect to any facts related to the

project is a violation of Federal law. To prevent any misunderstanding regarding the seriousness of these and similar acts, Form FHWA-1022 shall be posted on each Federal-aid highway project (23 CFR 635) in one or more places where it is readily available to all persons concerned with the project:

18 U.S.C. 1020 reads as follows:

"Whoever, being an officer, agent, or employee of the United States, or of any State or Territory, or whoever, whether a person, association, firm, or corporation, knowingly makes any false statement, false representation, or false report as to the character, quality, quantity, or cost of the material used or to be used, or the quantity or quality of the work performed or to be performed, or the cost thereof in connection with the submission of plans, maps, specifications, contracts, or costs of construction on any highway or related project submitted for approval to the Secretary of Transportation; or

Whoever knowingly makes any false statement, false representation, false report or false claim with respect to the character, quality, quantity, or cost of any work performed or to be performed, or materials furnished or to be furnished, in connection with the construction of any highway or related project approved by the Secretary of Transportation; or

Whoever knowingly makes any false statement or false representation as to material fact in any statement, certificate, or report submitted pursuant to provisions of the Federal-aid Roads Act approved July 1, 1916, (39 Stat. 355), as amended and supplemented;

Shall be fined under this title or imprisoned not more than 5 years or both."

#### IX. IMPLEMENTATION OF CLEAN AIR ACT AND FEDERAL WATER POLLUTION CONTROL ACT

This provision is applicable to all Federal-aid construction contracts and to all related subcontracts.

By submission of this bid/proposal or the execution of this contract, or subcontract, as appropriate, the bidder, proposer, Federal-aid construction contractor, or subcontractor, as appropriate, will be deemed to have stipulated as follows:

1. That any person who is or will be utilized in the performance of this contract is not prohibited from receiving an award due to a violation of Section 508 of the Clean Water Act or Section 306 of the Clean Air Act.

2. That the contractor agrees to include or cause to be included the requirements of paragraph (1) of this Section X in every subcontract, and further agrees to take such action as the contracting agency may direct as a means of enforcing such requirements.

#### X. CERTIFICATION REGARDING DEBARMENT, SUSPENSION, INELIGIBILITY AND VOLUNTARY EXCLUSION

This provision is applicable to all Federal-aid construction contracts, design-build contracts, subcontracts, lower-tier subcontracts, purchase orders, lease agreements, consultant contracts or any other covered transaction requiring FHWA approval or that is estimated to cost \$25,000 or more – as defined in 2 CFR Parts 180 and 1200.

##### 1. Instructions for Certification – First Tier Participants:

a. By signing and submitting this proposal, the prospective first tier participant is providing the certification set out below.

b. The inability of a person to provide the certification set out below will not necessarily result in denial of participation in this covered transaction. The prospective first tier

participant shall submit an explanation of why it cannot provide the certification set out below. The certification or explanation will be considered in connection with the department or agency's determination whether to enter into this transaction. However, failure of the prospective first tier participant to furnish a certification or an explanation shall disqualify such a person from participation in this transaction.

c. The certification in this clause is a material representation of fact upon which reliance was placed when the contracting agency determined to enter into this transaction. If it is later determined that the prospective participant knowingly rendered an erroneous certification, in addition to other remedies available to the Federal Government, the contracting agency may terminate this transaction for cause of default.

d. The prospective first tier participant shall provide immediate written notice to the contracting agency to whom this proposal is submitted if any time the prospective first tier participant learns that its certification was erroneous when submitted or has become erroneous by reason of changed circumstances.

e. The terms "covered transaction," "debarred," "suspended," "ineligible," "participant," "person," "principal," and "voluntarily excluded," as used in this clause, are defined in 2 CFR Parts 180 and 1200. "First Tier Covered Transactions" refers to any covered transaction between a grantee or subgrantee of Federal funds and a participant (such as the prime or general contract). "Lower Tier Covered Transactions" refers to any covered transaction under a First Tier Covered Transaction (such as subcontracts). "First Tier Participant" refers to the participant who has entered into a covered transaction with a grantee or subgrantee of Federal funds (such as the prime or general contractor). "Lower Tier Participant" refers any participant who has entered into a covered transaction with a First Tier Participant or other Lower

Tier Participants (such as subcontractors and suppliers).

f. The prospective first tier participant agrees by submitting this proposal that, should the proposed covered transaction be entered into, it shall not knowingly enter into any lower tier covered transaction with a person who is debarred, suspended, declared ineligible, or voluntarily excluded from participation in this covered transaction, unless authorized by the department or agency entering into this transaction.

g. The prospective first tier participant further agrees by submitting this proposal that it will include the clause titled "Certification Regarding Debarment, Suspension, Ineligibility and Voluntary Exclusion-Lower Tier Covered Transactions," provided by the department or contracting agency, entering into this covered transaction, without modification, in all lower tier covered transactions and in all solicitations for lower tier covered transactions exceeding the \$25,000 threshold.

h. A participant in a covered transaction may rely upon a certification of a prospective participant in a lower tier covered transaction that is not debarred, suspended, ineligible, or voluntarily excluded from the covered transaction, unless it knows that the certification is erroneous. A participant is responsible for ensuring that its principals are not suspended, debarred, or otherwise ineligible to participate in covered transactions. To verify the eligibility of its principals, as well as the eligibility of any lower tier prospective participants, each participant may, but is not required to, check the Excluded Parties List System website (<https://www.epls.gov/>), which is compiled by the General Services Administration.

i. Nothing contained in the foregoing shall be construed to require the establishment of a system of records in order to render in good faith the certification required by this clause. The knowledge and information of

the prospective participant is not required to exceed that which is normally possessed by a prudent person in the ordinary course of business dealings.

j. Except for transactions authorized under paragraph (f) of these instructions, if a participant in a covered transaction knowingly enters into a lower tier covered transaction with a person who is suspended, debarred, ineligible, or voluntarily excluded from participation in this transaction, in addition to other remedies available to the Federal Government, the department or agency may terminate this transaction for cause or default.

\* \* \* \* \*

## 2. Certification Regarding Debarment, Suspension, Ineligibility and Voluntary Exclusion – First Tier Participants:

a. The prospective first tier participant certifies to the best of its knowledge and belief, that it and its principals:

(1) Are not presently debarred, suspended, proposed for debarment, declared ineligible, or voluntarily excluded from participating in covered transactions by any Federal department or agency;

(2) Have not within a three-year period preceding this proposal been convicted of or had a civil judgment rendered against them for commission of fraud or a criminal offense in connection with obtaining, attempting to obtain, or performing a public (Federal, State or local) transaction or contract under a public transaction; violation of Federal or State antitrust statutes or commission of embezzlement, theft, forgery, bribery, falsification or destruction of records, making false statements, or receiving stolen property;

(3) Are not presently indicted for or otherwise criminally or civilly charged by a governmental entity (Federal, State or local) with commission of any of the offenses enumerated in paragraph (a)(2) of this

certification; and

(4) Have not within a three-year period preceding this application/proposal had one or more public transactions (Federal, State or local) terminated for cause or default.

b. Where the prospective participant is unable to certify to any of the statements in this certification, such prospective participant shall attach an explanation to this proposal.

## **2. Instructions for Certification - Lower Tier Participants:**

(Applicable to all subcontracts, purchase orders and other lower tier transactions requiring prior FHWA approval or estimated to cost \$25,000 or more - 2 CFR Parts 180 and 1200)

a. By signing and submitting this proposal, the prospective lower tier is providing the certification set out below.

b. The certification in this clause is a material representation of fact upon which reliance was placed when this transaction was entered into. If it is later determined that the prospective lower tier participant knowingly rendered an erroneous certification, in addition to other remedies available to the Federal Government, the department, or agency with which this transaction originated may pursue available remedies, including suspension and/or debarment.

c. The prospective lower tier participant shall provide immediate written notice to the person to which this proposal is submitted if at any time the prospective lower tier participant learns that its certification was erroneous by reason of changed circumstances.

d. The terms "covered transaction," "debarred," "suspended," "ineligible," "participant," "person," "principal," and "voluntarily excluded," as used in this clause, are defined in 2 CFR Parts 180 and 1200. You may contact the person to which this

proposal is submitted for assistance in obtaining a copy of those regulations. "First Tier Covered Transactions" refers to any covered transaction between a grantee or subgrantee of Federal funds and a participant (such as the prime or general contract). "Lower Tier Covered Transactions" refers to any covered transaction under a First Tier Covered Transaction (such as subcontracts). "First Tier Participant" refers to the participant who has entered into a covered transaction with a grantee or subgrantee of Federal funds (such as the prime or general contractor). "Lower Tier Participant" refers any participant who has entered into a covered transaction with a First Tier Participant or other Lower Tier Participants (such as subcontractors and suppliers).

e. The prospective lower tier participant agrees by submitting this proposal that, should the proposed covered transaction be entered into, it shall not knowingly enter into any lower tier covered transaction with a person who is debarred, suspended, declared ineligible, or voluntarily excluded from participation in this covered transaction, unless authorized by the department or agency with which this transaction originated.

f. The prospective lower tier participant further agrees by submitting this proposal that it will include this clause titled "Certification Regarding Debarment, Suspension, Ineligibility and Voluntary Exclusion-Lower Tier Covered Transaction," without modification, in all lower tier covered transactions and in all solicitations for lower tier covered transactions exceeding the \$25,000 threshold.

g. A participant in a covered transaction may rely upon a certification of a prospective participant in a lower tier covered transaction that is not debarred, suspended, ineligible, or voluntarily excluded from the covered transaction, unless it knows that the certification is erroneous. A participant is responsible for ensuring that its principals are not suspended, debarred, or otherwise

ineligible to participate in covered transactions. To verify the eligibility of its principals, as well as the eligibility of any lower tier prospective participants, each participant may, but is not required to, check the Excluded Parties List System website (<https://www.epls.gov/>), which is compiled by the General Services Administration.

h. Nothing contained in the foregoing shall be construed to require establishment of a system of records in order to render in good faith the certification required by this clause. The knowledge and information of participant is not required to exceed that which is normally possessed by a prudent person in the ordinary course of business dealings.

i. Except for transactions authorized under paragraph e of these instructions, if a participant in a covered transaction knowingly enters into a lower tier covered transaction with a person who is suspended, debarred, ineligible, or voluntarily excluded from participation in this transaction, in addition to other remedies available to the Federal Government, the department or agency with which this transaction originated may pursue available remedies, including suspension and/or debarment.

\* \* \* \* \*

**Certification Regarding Debarment, Suspension, Ineligibility and Voluntary Exclusion--Lower Tier Participants:**

1. The prospective lower tier participant certifies, by submission of this proposal, that neither it nor its principals is presently debarred, suspended, proposed for debarment, declared ineligible, or voluntarily excluded from participating in covered transactions by any Federal department or agency.

2. Where the prospective lower tier participant is unable to certify to any of the statements in this certification, such prospective participant shall attach an explanation to this proposal.

\* \* \* \* \*

**XI. CERTIFICATION REGARDING USE OF CONTRACT FUNDS FOR LOBBYING**

This provision is applicable to all Federal-aid construction contracts and to all related subcontracts which exceed \$100,000 (49 CFR 20).

1. The prospective participant certifies, by signing and submitting this bid or proposal, to the best of his or her knowledge and belief, that:

a. No Federal appropriated funds have been paid or will be paid, by or on behalf of the undersigned, to any person for influencing or attempting to influence an officer or employee of any Federal agency, a Member of Congress, an officer or employee of Congress, or an employee of a Member of Congress in connection with the awarding of any Federal contract, the making of any Federal grant, the making of any Federal loan, the entering into of any cooperative agreement, and the extension, continuation, renewal, amendment, or modification of any Federal contract, grant, loan, or cooperative agreement.

b. If any funds other than Federal appropriated funds have been paid or will be paid to any person for influencing or attempting to influence an officer or employee of any Federal agency, a Member of Congress, an officer or employee of Congress, or an employee of a Member of Congress in connection with this Federal contract, grant, loan, or cooperative agreement, the undersigned shall complete and submit Standard Form-LLL, "Disclosure Form to Report Lobbying," in accordance with its instructions.

2. This certification is a material representation of fact upon which reliance was placed when this transaction was made or entered into. Submission of this certification is a prerequisite for making or entering into this transaction imposed by 31 U.S.C. 1352. Any person who fails to file the

required certification shall be subject to a civil penalty of not less than \$10,000 and not more than \$100,000 for each such failure.

3. The prospective participant also agrees by submitting its bid or proposal that the participant shall require that the language of this certification be included in all lower tier subcontracts, which exceed \$100,000 and that all such recipients shall certify and disclose accordingly.

#### **ATTACHMENT A EMPLOYMENT AND MATERIALS PREFERENCE FOR APPALACHIAN DEVELOPMENT HIGHWAY SYSTEM OR APPALACHIAN LOCAL ACCESS ROAD CONTRACTS**

This provision is applicable to all Federal-aid projects funded under the Appalachian Regional Development Act of 1965.

1. During the performance of this contract, the contractor undertaking to do work which is, or reasonably may be, done as on-site work, shall give preference to qualified persons who regularly reside in the labor area as designated by the DOL wherein the contract work is situated, or the subregion, or the Appalachian counties of the State wherein the contract work is situated, except:

- a. To the extent that qualified persons regularly residing in the area are not available.
- b. For the reasonable needs of the contractor to employ supervisory or specially experienced personnel necessary to assure an efficient execution of the contract work.
- c. For the obligation of the contractor to offer employment to present or former employees as the result of a lawful collective bargaining contract, provided that the number of nonresident persons employed under this subparagraph (1c) shall not exceed 20 percent of the total number of employees employed by the contractor on the contract work, except as provided in

subparagraph (4) below.

2. The contractor shall place a job order with the State Employment Service indicating (a) the classifications of the laborers, mechanics and other employees required to perform the contract work, (b) the number of employees required in each classification, (c) the date on which the participant estimates such employees will be required, and (d) any other pertinent information required by the State Employment Service to complete the job order form. The job order may be placed with the State Employment Service in writing or by telephone. If during the course of the contract work, the information submitted by the contractor in the original job order is substantially modified, the participant shall promptly notify the State Employment Service.

3. The contractor shall give full consideration to all qualified job applicants referred to him by the State Employment Service. The contractor is not required to grant employment to any job applicants who, in his opinion, are not qualified to perform the classification of work required.

4. If, within one week following the placing of a job order by the contractor with the State Employment Service, the State Employment Service is unable to refer any qualified job applicants to the contractor, or less than the number requested, the State Employment Service will forward a certificate to the contractor indicating the unavailability of applicants. Such certificate shall be made a part of the contractor's permanent project records. Upon receipt of this certificate, the contractor may employ persons who do not normally reside in the labor area to fill positions covered by the certificate, notwithstanding the provisions of subparagraph (1c) above.

5. The provisions of 23 CFR 633.207(e) allow the contracting agency to provide a contractual preference for the use of mineral resource materials native to the Appalachian region.

6. The contractor shall include the provisions of Sections 1 through 4 of this Attachment A in every subcontract for work which is, or reasonably may be, done as on-site work.

## REFERENCE SHEET

All bidders are required to complete this form providing three references of past performance. References should involve projects and/or service situations of similar size, scope, and character of work to this Bid. References must have had dealings with the Bidder within the last thirty-six (36) months. The County reserves the right to contact any or all of the references supplied for an evaluation of past performance in order to establish the responsibility of the Bidder before the actual award of the Bid and/or Contract. Completion of the Reference Form is required.

BIDDER'S NAME: \_\_\_\_\_

DATE FILED: \_\_\_\_\_

REFERENCE'S NAME: \_\_\_\_\_

ADDRESS: \_\_\_\_\_

TELEPHONE: \_\_\_\_\_ CONTACT PERSON: \_\_\_\_\_

REFERENCE'S NAME: \_\_\_\_\_

ADDRESS: \_\_\_\_\_

TELEPHONE: \_\_\_\_\_ CONTACT PERSON: \_\_\_\_\_

REFERENCE'S NAME: \_\_\_\_\_

ADDRESS: \_\_\_\_\_

TELEPHONE: \_\_\_\_\_ CONTACT PERSON: \_\_\_\_\_



**This Page Left Intentionally Blank**

**LOCAL LAW NUMBER 12- 2012 AMENDED BY LOCAL LAW NUMBER 5- 2015  
COUNTY OF CATTARAUGUS, NEW YORK**

Pursuant to Section 10 of the Municipal Home Rule Law and Section 103 of the  
General Municipal Law.

**A LOCAL LAW ESTABLISHING UNIFORM GUIDELINES FOR DETERMINING THE  
RESPONSIBILITY OF BIDDERS**

BE IT ENACTED by the Legislature of the County of Cattaraugus ("the County"), as follows:

Section 1. Legislative Intent. It is the intent of this Local Law to enhance the County's ability to identify the lowest "responsible bidder" on public works construction projects by instituting more comprehensive submission requirements and an evaluation system which is in compliance with New York State General Municipal Law. The County, based upon its experience, has determined that quality workmanship, efficient operation, safety, and timely completion of projects are not necessarily assured by awarding a public works contract solely on the basis of the low price. This Local Law establishing uniformity of guidelines for determining the responsibility of apparent low bidders will assure efficient use of taxpayer dollars, will promote public safety, and is in the public interest.

Section 2. Applicability. This Local Law shall apply to construction projects subject to the competitive bidding requirements of General Municipal Law §103 and advertised for bids on or after the effective date.

Section 3. Public Works. For purposes of this Local Law, the term "public works" shall mean the following: any constructing, altering, reconstructing, repairing, rehabilitating, refinishing, refurbishing, remodeling, remediating, renovating, custom fabricating, maintenance, landscaping, improving, moving, wrecking, painting, decorating, demolishing, and adding to or subtracting from any public building, structure, highway, roadway, street, alley, bridge, sewer, drain, ditch, sewage disposal plant, water work, parking facility, railroad, excavation, or other project, development, real property, or improvement, or to any part thereof, whether or not the performance of the work herein described involves the addition to, or fabrication into, any structure, project or development, real property or improvement herein described of any material or article of merchandise, which is paid for out of public funds in an amount exceeding the threshold for bidding established by the General Municipal Law. The term also includes any public works leased by the County under a lease containing an option to purchase exceeding the threshold for bidding public works projects established by the General Municipal Law.

Section 4. Cattaraugus County Vendor Responsibility Form and Procedure.

- A. A questionnaire (which shall be titled the "Cattaraugus County Vendor Responsibility Form"), hereinafter "the Form", shall be prepared and, as he/she may deem appropriate, revised by the Cattaraugus County Commissioner of Public Works ("Commissioner").
- B. The Commissioner shall provide the Form to the apparent low bidder on all County public works projects.
- C. The County shall promptly notify the apparent low bidder of its status as such and provide such entity with a copy of the Form either in electronic or paper format. The most current version of the Form shall also be posted on the Cattaraugus County website.

- D. The apparent low bidder shall file the Form in in the Office of the Commissioner not more than five (5) business days after receiving it or, if the form is mailed to the apparent low bidder, within ten (10) business days after the date of mailing.
- E. In the event that the apparent low bidder fails to file the fully completed Form in the Commissioner's Office within the required time, its bid will be rejected and any bid bond submitted may, at the County's sole discretion, be forfeited.
- F. If the apparent low bidder is deemed not responsible, or fails to submit the Form within the required time, then the next lowest bidder will be deemed the apparent low bidder and so on until the lowest bidder is deemed responsible and selected as the lowest responsible bidder.
- G. Not later than five (5) calendar days prior to a final determination that the apparent low bidder is not responsible, the County will notify the bidder of same, in writing, and by certified mail, return receipt, stating the reasons. Except in the case of the rejection of an apparent low bid solely because the vendor failed to timely submit a completed Form, such notice shall set forth a time, date and place for the apparent low bidder to appear and be heard, not less than five (5) business days after such notice is served.
- H. Subcontractors proposed to be used on a project must also complete and submit the Form within five (5) days after the preconstruction meeting before the subcontractor is approved by the County. Failure by a subcontractor to submit the Form or unsatisfactory responses to questions may lead to rejection of the bid of the subcontractor at the County's discretion.
- I. If the bid of the apparent low bidder appears disproportionately low when compared with estimates obtained by or on behalf of the County and/or compared to other bids submitted (10% or greater disparity), the County reserves the right to inquire further of the apparent low bidder to determine whether the bid contains mathematical errors, omissions and/or erroneous assumptions, and whether the apparent low bidder has the capability to perform and complete the contract for the bid amount.
- J. If a bidder is found to have willfully violated New York Labor Law §220 within the previous five (5) years, that bidder shall automatically be deemed "not responsible" and its bid shall be rejected unless the Commissioner, subject to review by the Public Works Committee of the Cattaraugus County Legislature, determines otherwise. In all other cases, based on all of the information collected pursuant to this local law and any other factor deemed relevant, the Commissioner, or other department heads soliciting public works bids, shall determine if the apparent lowest bidder is in fact "responsible."

#### Section 5. Additional Requirements.

- A. Contractors and all subcontractors shall classify their workers as employees rather than as independent contractors, unless those workers meet the definition of "independent contractor" as defined by the Internal Revenue Service, and shall treat said employees accordingly for purposes of workers' compensation insurance coverage, unemployment insurance, employment taxes, and social security taxes.
- B. The contractors and all subcontractors shall submit certified payrolls to the Commissioner.

Section 6. Procedure. Cattaraugus County will make its own determinations of responsibility for low bidders. A bidder recognized by the state as a responsible vendor must still satisfy the requirements of this local law by submitting the required Cattaraugus County Vendor Responsibility Form within the required time frame.

Section 7. Incomplete Submissions by Bidders and Subcontractors. It is the sole responsibility of the contractor to comply with all submission requirements to the County. The submission requirements also apply to all subcontractors, except that the contractor shall submit all subcontractor questionnaires to the County of Cattaraugus for approval. Failure to submit the Form may lead to the rejection of the bid of the subcontractor at the County's discretion. Contractor submissions deemed non-responsive will result in automatic rejection of the bid.

Section 8. Materiality. The requirements of this Local Law are a material part of the bid documents and the contract and the successful bidder shall insert this Local Law in all subcontracts.

Section 9. Severability. If any clause, sentence, paragraph, subdivision, section or part of this Local law or the application thereof, to any person, individual, corporation, firm, partnership, entity or circumstance, shall be adjudged by any court of competent jurisdiction to be invalid or unconstitutional such order of Judgment shall not affect, impair, or invalidate the remainder thereof, but shall be confined in its operation to the clause, sentence, paragraph, subdivision, section or part of this Local law or in its application to the person, individual, corporation, firm, partnership, entity, or circumstance directly involved In the controversy in which such judgment or order shall be rendered.

Section 10. Other Local Laws. Any prior Local Law or portion thereof in conflict with this Local Law is hereby repealed.

Section 11. Effective Date. This Local Law shall take effect upon filing in the Office of the Secretary of State, in accordance with Section 27 of the New York State Municipal Home Rule Law.

**IRAN DIVESTMENT ACT**

As a result of the Iran Divestment Act of 2012 (Act), Chapter 1 of the 2012 Laws of New York, a new provision has been added to the State Finance Law (SFL), § 165-a, effective April 12, 2012. Under the Act, the Commissioner of the Office of General Services (OGS) will be developing a list (prohibited entities list) of "persons" who are engaged in "investment activities in Iran" (both are defined terms in the law). Pursuant to SFL § 165-a(3)(b), the initial list is expected to be issued no later than 120 days after the Act's effective date, at which time it will be posted on the OGS website.

By entering into this Contract, Contractor (or any assignee) certifies that once the prohibited entities list is posted on the OGS website, it will not utilize on such Contract any subcontractor that is identified on the prohibited entities list. Additionally, Contractor agrees that after the list is posted on the OGS website, should it seek to renew or extend the Contract, it will be required to certify at the time the Contract is renewed or extended that it is not included on the prohibited entities list. Contractor also agrees that any proposed Assignee of the Contract will be required to certify that it is not on the prohibited entities list before the New York State Department of Transportation (NYSDOT) may approve a request for Assignment of Contract

During the term of the Contract, should NYSDOT receive information that a person is in violation of the above referenced certification, NYSDOT will offer the person an opportunity to respond. If the person fails to demonstrate that it has ceased its engagement in the investment which is in violation of the Act within 90 days after the determination of such violation, then NYSDOT shall take such action as may be appropriate including, but not limited to, imposing sanctions, seeking compliance, recovering damages, or declaring the Contractor in default.

The Sponsor reserves the right to reject any request for assignment for an entity that appears on the prohibited entities list prior to the award of a contract, and to pursue a responsibility review with respect to any entity that is awarded a contract and appears on the prohibited entities list after contract award.

Corporate or Company Name

By: \_\_\_\_\_  
Signature

\_\_\_\_\_  
Title

Sworn to before me this  
\_\_\_\_ Day of \_\_\_\_\_, 20\_\_\_\_

\_\_\_\_\_  
Notary Public

**This Page Left Intentionally Blank**

# CATTARAUGUS COUNTY

## DEPARTMENT OF PUBLIC WORKS

*Development – Progress – Workmanship*

Kathleen M. Ellis, Commissioner  
Devin M. Blue, Deputy Commissioner  
Mark C. Burr, PE, Director of Engineering



8810 Route 242, Jack Ellis Drive  
Little Valley, New York 14755  
Phone (716) 938 9121  
Fax (716) 938 2754

**PROJECT TITLE: Replacement of New Albion Bridge #35 (B.I.N. 3322810)  
Tannery Street Bridge over Tributary South Branch Cattaraugus Creek**

### AFFIDAVIT OF COMPLIANCE AND RECEIPT OF PREVAILING WAGE SCHEDULE

The Contractor named below certifies receipt of Prevailing Wage Rate Schedule and is in compliance with all labor laws and regulations of the State of New York and the United States of America including the following:

1. PREVAILING WAGE RATE: The contractor agrees to comply with the schedule of wages applicable to the performance of the said contract and the statutory requirements and rules of the State of New York. The Contractor named below certifies that they have received the Prevailing Wage Rate Schedule **PRC# 2018014342**.
2. SOCIAL SECURITY TAXES: The contractor promises and agrees to pay the taxes measured by the wages of their employees required by the Federal Social Security Act and all amendments thereto, and to accept the exclusive liability for said taxes.

\_\_\_\_\_  
Company

\_\_\_\_\_  
Print Name Title

\_\_\_\_\_  
Signature Date

State of New York )  
) ss:  
County of \_\_\_\_\_ )

Subscribed and Sworn to before me this \_\_\_\_\_ day of \_\_\_\_\_ 20 \_\_\_\_

By \_\_\_\_\_

Notary Public, \_\_\_\_\_

## **ONE-CALL NOTIFICATION TRAINING CERTIFICATION**

The Contractor certifies that its excavator(s), operator(s), and/or subcontractor(s), if any, have completed the training and education program provided by the One-Call Notification System pursuant to Article 36 of the NYS General Business Law and any other provider authorized by the Public Service Commission to administer such training and education program. The Contractor shall submit certificates of training with its bid.



## Section 3

<b>SUPPLEMENTAL INFORMATION</b>
---------------------------------

---

65CONR 9 (3/11) - SUPPLEMENTAL INFORMATION AVAILABLE TO BIDDERS

---

SIGN FACE LAYOUTS

---

EARTHWORK SUMMARY SHEETS

---

SUBSURFACE INVESTIGATION BORING LOGS

---

NYSDEC WATER QUALITY CERTIFICATION LETTER

---

USACE PERMIT

---

---

---

---

---

---

---

---

---

---

---

**This Page Left Intentionally Blank**

**65CONR 9 (3/11) SUPPLEMENTAL INFORMATION AVAILABLE TO BIDDERS**

The following information is available at the Office having jurisdiction for this project, as identified in the advertisement for bids, for inspection and review prior to the letting date. The bidder's signature on this proposal certifies that they have made themselves aware of the availability, for their inspection and review prior to the letting date, of the information indicated below:

INFORMATION	Available	Not Available
1. Asbestos Information		
a. Asbestos Blanket Variances	<input type="checkbox"/>	<input checked="" type="checkbox"/>
b. Asbestos Report	<input type="checkbox"/>	<input checked="" type="checkbox"/>
2. Cross Sections	<input checked="" type="checkbox"/>	<input type="checkbox"/>
3. Quantity Information		
a. Quantity Work-ups – All	<input type="checkbox"/>	<input checked="" type="checkbox"/>
b. Quantity Work-ups – Partial (specify)	<input type="checkbox"/>	<input checked="" type="checkbox"/>
4. Record Plans (partial)	<input checked="" type="checkbox"/>	<input type="checkbox"/>
5. Rock Cores (available for inspection only)	<input type="checkbox"/>	<input checked="" type="checkbox"/>
6. Sign Face Layouts	<input checked="" type="checkbox"/>	<input type="checkbox"/>
7. Stormwater Pollution Prevention Plan (SWPPP)	<input checked="" type="checkbox"/>	<input type="checkbox"/>
8. Subsurface Information		
a. Subsurface Exploration Logs	<input checked="" type="checkbox"/>	<input type="checkbox"/>
b. Undisturbed Sample Logs	<input type="checkbox"/>	<input checked="" type="checkbox"/>
c. Laboratory Test Data from Soil Samples	<input checked="" type="checkbox"/>	<input type="checkbox"/>
d. Tabulated Results of Probing	<input type="checkbox"/>	<input checked="" type="checkbox"/>
e. Tabulated Depth to Bedrock	<input type="checkbox"/>	<input checked="" type="checkbox"/>
f. Rock Core Evaluation Logs	<input type="checkbox"/>	<input checked="" type="checkbox"/>
g. Compression Test Data from Rock Samples	<input type="checkbox"/>	<input checked="" type="checkbox"/>
h. Rock Outcrop Maps	<input type="checkbox"/>	<input checked="" type="checkbox"/>
i. Granular Materials Resource Survey Reports	<input type="checkbox"/>	<input checked="" type="checkbox"/>
j. Terrain Reconnaissance Reports	<input type="checkbox"/>	<input checked="" type="checkbox"/>
9. Subsurface Information - Other Information		
a. Subsurface information from outside sources	<input checked="" type="checkbox"/>	<input type="checkbox"/>
b. Source Information - Granular Material and aggregates	<input type="checkbox"/>	<input checked="" type="checkbox"/>
c. Special Subsurface Reports	<input type="checkbox"/>	<input checked="" type="checkbox"/>
10. Anticipated Construction Schedule	<input type="checkbox"/>	<input checked="" type="checkbox"/>
11. Special Reports or Other Information:		
a. Design Approval Document	<input checked="" type="checkbox"/>	<input type="checkbox"/>
b. Wetland Compensation Report	<input type="checkbox"/>	<input checked="" type="checkbox"/>
c. Survey Control Report	<input type="checkbox"/>	<input checked="" type="checkbox"/>

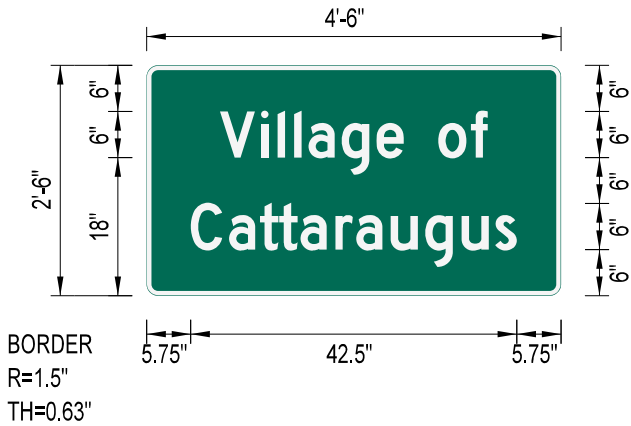
**This Page Left Intentionally Blank**

# **SIGN FACE LAYOUTS**

**This Page Left Intentionally Blank**

# SIGN DETAIL

NTS



BORDER  
R=1.5"  
TH=0.63"

Panel Style: Information Sign (NY112-2a).ssi  
M.U.T.C.D.: 2009 Edition

Panel Style: Information Sign (NY112-2a).ssi  
Dimensions are in inches.tenths

Letter locations are panel edge to lower left corner

SIGN NUMBER	Village of Cattaraugus
WIDTH x HGHT.	4'-6" x 2'-6"
BORDER WIDTH	0.63"
CORNER RADIUS	1.5"
MOUNTING	Ground
BACKGROUND	TYPE: Reflective
	COLOR: Green
LEGEND/BORDER	TYPE: Reflective
	COLOR: White/White

SYMBOL	ROT	X	Y	WID	HT

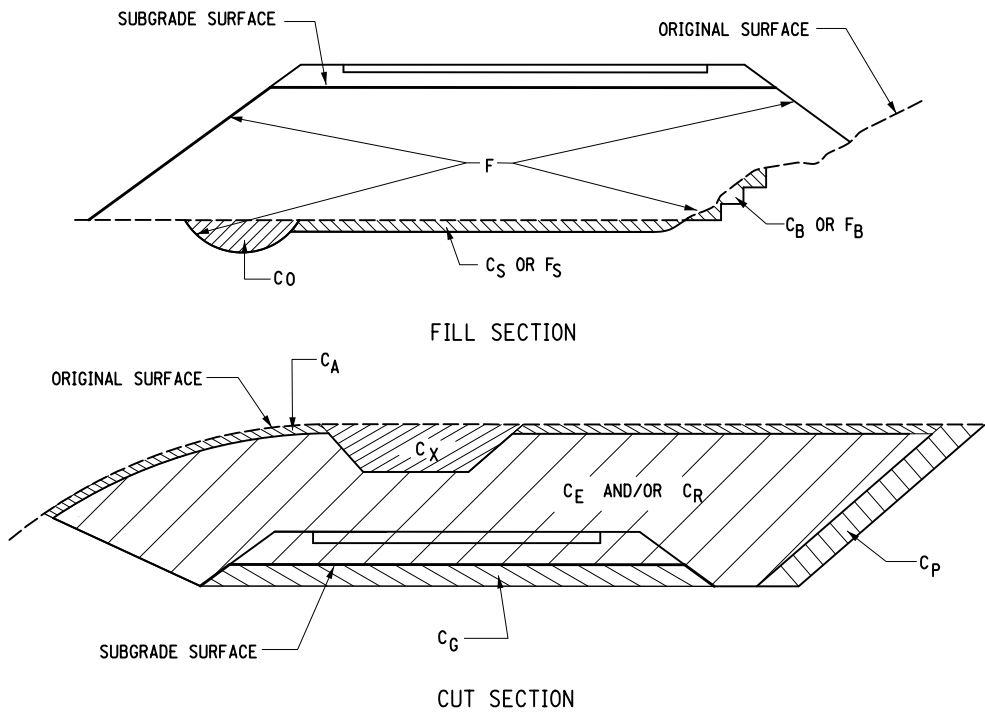
LETTER POSITIONS (X)												LENGTH	SERIES/SIZE						
V	i	l	l	a	g	e	o	f											D 2000
9.6	14.9	17.1	19.2	21.1	25.4	30	38	42.3										34.9	6/4.5
C	a	t	t	a	r	a	u	g	u	s									D 2000
5.8	10.7	14.8	17.3	20	24.6	27.3	31.8	36.3	41	45.4								42.5	6/4.5

**This Page Left Intentionally Blank**



# **EARTHWORK SUMMARY SHEETS**

**This Page Left Intentionally Blank**



**DEFINITIONS:**

- C<sub>B</sub> - EXCAVATION FOR REQUIRED BENCHING, (BOTH LONGITUDINAL AND TRANSVERSE).
- C<sub>G</sub> - EXCAVATION FOR SUBGRADE IMPROVEMENT.
- C<sub>P</sub> - EXCAVATION FROM CUT SLOPE NECESSARY TO PLACE SLOPE PROTECTION.
- C<sub>E</sub> - PORTION OF CUT ASSUMED TO BE EARTH SUITABLE FOR EMBANKMENT CONSTRUCTION, EXCLUDING C<sub>G</sub> AND C<sub>P</sub>.
- T<sub>E</sub> - (C<sub>B</sub> + C<sub>G</sub> + C<sub>P</sub> + C<sub>E</sub>) TOTAL EARTH EXCAVATION ASSUMED SUITABLE FOR EMBANKMENT CONSTRUCTION.
- C<sub>A</sub> - EXCAVATION OF TOPSOIL (UNSUITABLE MATERIAL) IN CUT.
- C<sub>S</sub> - EXCAVATION OF TOPSOIL (UNSUITABLE MATERIAL) UNDER EMBANKMENT.
- C<sub>X</sub> - EXCAVATION OF UNSUITABLE MATERIAL IN CUT: SWAMP OR DUMP
- C<sub>0</sub> - EXCAVATION OF UNSUITABLE MATERIAL BENEATH EMBANKMENT: SWAMP OR DUMP
- T<sub>U</sub> - (C<sub>A</sub> + C<sub>S</sub> + C<sub>X</sub> + C<sub>0</sub>) TOTAL EXCAVATION ASSUMED UNSUITABLE FOR EMBANKMENT CONSTRUCTION.
- C<sub>R</sub> - PORTION OF CUT ASSUMED TO BE ROCK, INCLUDING C<sub>G</sub> IF APPLICABLE.
- C<sub>T</sub> - (T<sub>E</sub> + T<sub>U</sub> + C<sub>R</sub>) TOTAL EXCAVATION.
- F<sub>B</sub> - FILL REQUIRED TO REPLACE BENCHES.
- F<sub>S</sub> - FILL REQUIRED TO REPLACE TOPSOIL REMOVED BENEATH EMBANKMENTS.
- F - FILL REQUIRED TO COMPLETE EMBANKMENT TO SUBGRADE SURFACE AND SIDE-SLOPES AFTER FOUNDATION IS PREPARED.
- F<sub>T</sub> - (F<sub>B</sub> + F<sub>S</sub> + F) TOTAL FILL REQUIRED.
- T<sub>A</sub> - (T<sub>E</sub> × F<sub>E</sub> + C<sub>R</sub> × F<sub>R</sub>) THE VOLUME WHICH THE SUITABLE EXCAVATED MATERIAL COULD OCCUPY IN EMBANKMENT.
- F<sub>E</sub> - SHRINKAGE FACTOR FOR EARTH
- F<sub>R</sub> - SWELL FACTOR FOR ROCK

ALL DIMENSIONS ARE IN yd <sup>3</sup> UNLESS OTHERWISE NOTED	
CATTARAUGUS COUNTY DEPARTMENT OF PUBLIC WORKS	Stantec
EARTHWORK SUMMARY SHEET DEFINITIONS	REGION 5

FILE NAME = U:\192500172\Transportation\Specification\ESS-1 & 2.dgn  
 DATE/TIME = 4/5/2019 2:43:39 PM  
 USER = dtclark


SUMMARY OF EARTHWORK (ITEMS 203.02 AND 203.03 ONLY)					
SOURCE	EXCAVATION			ITEM 203.02	ITEM 203.03
	T <sub>E</sub>	C <sub>R</sub>	T <sub>U</sub>	C <sub>T</sub>	F <sub>T</sub>
5+00 TO 10+00	650 CY	0 CY	0 CY	650 CY	1487 CY
CHANNEL BANK	722 CY	0 CY	38 CY	760 CY	8 CY
PLUNGE POOL	1966 CY	0 CY	100 CY	2066 CY	44 CY
BIORETENTION	421 CY	0 CY	26 CY	447 CY	0 CY
WATERWAYS DIVERSION	5002 CY	0 CY	197 CY	5199 CY	4482 CY
BRIDGE	0 CY	0 CY	0 CY	0 CY	3375 CY
MAINTENANCE PATH	23 CY	0 CY	0 CY	23 CY	0 CY
<b>TOTALS</b>	<b>8784 CY</b>	<b>0 CY</b>	<b>361 CY</b>	<b>9145 CY</b>	<b>9396 CY</b>

SUMMARY OF TRENCH AND CULVERT EXCAVATION (ITEM 206.0201 ONLY)			
SOURCE	EXCAVATION		ITEM 206.0201
	ROCK	NON-ROCK	
STORM SEWER	0 CY	142 CY	142 CY
WATER SERVICE	0 CY	278 CY	278 CY
STONE KEYWAY	0 CY	233 CY	233 CY
BIORETENTION	0 CY	97 CY	97 CY
<b>TOTALS</b>	<b>0 CY</b>	<b>750 CY</b>	<b>750 CY</b>

**NOTES:**

THE CONTRACTOR'S ATTENTION IS DIRECTED TO THE FACT THAT THESE ARE ESTIMATED, AND ARE PROVIDED FOR THE PURPOSE OF PREPARING AN ESTIMATE. THEY ARE NOT TO BE CONSTRUED AS BEING EXACT. THEY ARE INTENDED TO QUANTIFY AND QUALIFY THE NATURE OF THE WORK. SIGNIFICANT DIFFERENCE FROM THIS REPRESENTATION, WHEN ENCOUNTERED DURING THE ACTUAL WORK, WILL BE HANDLED ACCORDING TO THE SPECIFICATIONS GOVERNING THIS PROJECT

- 203.02 UNCLASSIFIED EXCAVATION AND DISPOSAL
- 203.03 EMBANKMENT IN PLACE
- 206.0201 TRENCH AND CULVERT EXCAVATION

ALL QUANTITIES ARE IN yd <sup>3</sup> UNLESS OTHERWISE NOTED	
CATTARAUGUS COUNTY DEPARTMENT OF PUBLIC WORKS	 <b>Stantec</b>
EARTHWORK SUMMARY SHEET	REGION 5

FILE NAME = U:\192500172\Transportation\Specification\ESS-1 & 2.dgn  
 DATE/TIME = 6/20/2019 5:27:39 PM  
 USER = dtclark

**SUBSURFACE INVESTIGATION**  
**BORING LOGS**

**This Page Left Intentionally Blank**

DATE  
 START 8/8/2007  
 FINISH 8/8/2007  
 SHEET 1 OF 3

**SJB SERVICES, INC.**  
**SUBSURFACE LOG**



HOLE NO. B-1  
 SURF. ELEV. \_\_\_\_\_  
 G.W. DEPTH See Notes

PROJECT: REPLACEMENT OF TANNERY STREET BRIDGE LOCATION: OVER TRIBUTARY S. BR. CATT. CREEK  
 PROJ. NO.: BD-07-106 VILLAGE OF CATTARAUGUS, NY

DEPTH FT.	SMPL NO.	BLOWS ON SAMPLER				SOIL OR ROCK CLASSIFICATION	NOTES
		0/6	6/12	12/18	N		
5	1	6	6			Brown Silty f-c SAND, some fine Gravel, tr. brick (dry, FILL)	Installed 2" diameter monitoring well to a depth of 20- feet, 10- feet screen with flush mount casing.
		9	13		15		
5	2	10	11			Brown Silty f-c SAND, some fine Gravel (moist, firm, SM)	
		10	10		21		
5	3	4	2			(loose)	
		5	6		7		
10	4	5	4				
		2	3		6		
10	5	3	10			(firm)	
		12	10		22		
15	6	10	6				
		6	6		12		
15	7	3	2			(loose)	
		2	2		4		
15	8	5	5			(firm)	
		5	50		10		
20	9	50/0.3				(wet, v. compact)	
					REF		
20	10	50/0.3					
					REF		
25	11	6	4			(loose)	
		4	3		8		
25	12	4	3			Grey Silty CLAY, tr. sand, tr. gravel (moist, medium, CL- ML)	
		3	3		6		
25	13	2	3				
		4	6		7		
30	14	4	6			(stiff)	
		5	6		11		
30	15	1	3			(medium)	
		3	4		6		
35	16	2	2				
		4	4		6		
35	17	6	5			(stiff)	
		7	9		12		
35	18	2	2			(medium)	
		4	5		6		
40	19	2	3				
		3	2		6		
40	20	WOH/12					
		1	3		1		

No Recovery Sample #10

Poor Recovery Sample #11

REF= Sample Spoon Refusal

WOH= Weight of Hammer and Rods

N = NO. BLOWS TO DRIVE 2-INCH SPOON 12-INCHES WITH A 140 LB. PIN WT. FALLING 30-INCHES PER BLOW CLASSIFIED BY: Geologist  
 DRILLER: A. JAKUBCZAK DRILL RIG TYPE: CME- 75  
 METHOD OF INVESTIGATION ASTM D-1586 USING HOLLOW STEM AUGERS

DATE  
 START 8/13/2007  
 FINISH 8/13/2007  
 SHEET 2 OF 3

**SJB SERVICES, INC.**  
**SUBSURFACE LOG**



HOLE NO. B-1  
 SURF. ELEV. \_\_\_\_\_  
 G.W. DEPTH See Notes

PROJECT: REPLACEMENT OF TANNERY STREET BRIDGE LOCATION: OVER TRIBUTARY S. BR. CATT. CREEK  
 PROJ. NO.: BD-07-106 VILLAGE OF CATTARAUGUS, NY

DEPTH FT.	SMPL NO.	BLOWS ON SAMPLER				SOIL OR ROCK CLASSIFICATION	NOTES
		0/6	6/12	12/18	N		
45	21	WOH	1			(soft)	WOH= Weight of Hammer and Rods
		3	3		4		
	22	3	5			(stiff)	
		5	7		10		
50	23	WOH	WOH			(soft)	
		3	3		3		
	24	3	4			(medium)	
		3	3		7		
55	25	WOH	WOH			(v. soft)	
		1	3		1		
	26	WOH	WOH			(medium)	
		5	5		5		
	27	4	4			(stiff)	
		5	6		9		
60	28	WOH	WOH			(v. soft)	
		WOH	4		0		
	29	3	3			(medium)	
		4	3		7		
65	30	WOH	3				
		3	4		6		
	31	1	2				
		2	3		4		
	32	3	3				
		4	5		7		
70	33	WOH	WOH			(v. soft)	
		4	4		4		
	34	3	3			(medium)	
		3	3		6		
75	35	WOH	WOH				
		1	3		1		
	36	WOH	2			(medium)	
		2	4		4		
	37	3	3				
		4	5		7		
80	38	1	3			(stiff)	
		4	5		7		
	39	6	5				
		6	9		11		
	40	3	3				
		6	5		9		

N = NO. BLOWS TO DRIVE 2-INCH SPOON 12-INCHES WITH A 140 LB. PIN WT. FALLING 30-INCHES PER BLOW CLASSIFIED BY: Geologist  
 DRILLER: A. JAKUBCZAK DRILL RIG TYPE: CME-75  
 METHOD OF INVESTIGATION ASTM D-1586 USING HOLLOW STEM AUGERS



DATE  
 START 8/13/2007  
 FINISH 8/13/2007  
 SHEET 3 OF 3

**SJB SERVICES, INC.**  
**SUBSURFACE LOG**



HOLE NO. B-1  
 SURF. ELEV. \_\_\_\_\_  
 G.W. DEPTH See Notes

PROJECT: REPLACEMENT OF TANNERY STREET BRIDGE LOCATION: OVER TRIBUTARY S. BR. CATT. CREEK  
 PROJ. NO.: BD-07-106 VILLAGE OF CATTARAUGUS, NY

DEPTH FT.	SMPL NO.	BLOWS ON SAMPLER				SOIL OR ROCK CLASSIFICATION	NOTES
		0/6	6/12	12/18	N		
85	41	4	3			(medium)	
		4	4		7		
85	42	6	4			(medium)	
		3	5		7		
85	43	1	2			(medium)	
		3	5		5		
85	44	3	3			(medium)	
		4	6		7		
90	45	3	3			(medium)	
		4	5		7		
90	46	4	4			(stiff)	
		6	5		10		
90	47	4	4			(stiff)	
		7	3		11		
95	48	3	2			(medium)	
		2	4		4		
95	49	2	2			(medium)	
		4	5		6		
100	50	3	4			(stiff)	
		5	6		9		
100	51	4	3			(medium)	
		3	3		6		
100	52	2	4			(medium)	
		4	3		8		
105	53	WOH	1			(soft)	
		2	2		3		
105	54	3	2			(medium)	
		3	3		5		
110	55	1	2			(medium)	
		2	4		4		
110	56	3	2			(medium)	
		3	4		5		
110	57	2	3			(medium)	
		2	4		5		
115	58	WOH	1			(soft)	
		2	2		3		
115	59	3	2			(medium)	
		3	3		5		
120	60	1	2			(medium)	
		3	5		5		

WOH= Weight of Hammer  
and Rods

Boring Complete at 120.0'

No Free Standing  
Water Reading Obtained  
at Boring Completion

N = NO. BLOWS TO DRIVE 2-INCH SPOON 12-INCHES WITH A 140 LB. PIN WT. FALLING 30-INCHES PER BLOW CLASSIFIED BY: Geologist  
 DRILLER: A. JAKUBCZAK DRILL RIG TYPE: CME- 75  
 METHOD OF INVESTIGATION ASTM D-1586 USING HOLLOW STEM AUGERS

DATE  
 START 8/15/2007  
 FINISH 8/15/2007  
 SHEET 1 OF 1

**SJB SERVICES, INC.**  
**SUBSURFACE LOG**



HOLE NO. B-2  
 SURF. ELEV. \_\_\_\_\_  
 G.W. DEPTH See Notes

PROJECT: REPLACEMENT OF TANNERY STREET BRIDGE LOCATION: OVER TRIBUTARY S. BR. CATT. CREEK  
 PROJ. NO.: BD-07-106 VILLAGE OF CATTARAUGUS, NY

DEPTH FT.	SMPL NO.	BLOWS ON SAMPLER				SOIL OR ROCK CLASSIFICATION	NOTES
		0/6	6/12	12/18	N		
5	1	5	4			Brown Silty f-c SAND, some Clay, tr. gravel (moist, FILL)	
		4	5		8		
5	2	5	4			Contains silty Clay, some f-c Sand	
		5	7		9		
5	3	6	6			Contains tr. sand	
		5	7		11		
10	4	5	5			Contains silty f-c Sand, some Clay	
		7	7		12		
10	5	5	4				
		3	4		7		
15	6	4	6				
		5	6		11		
15	7	4	5				
		4	4		9		
15	8	50/0.2				refusal on concrete, move boring 2'	Poor Recovery Sample #8
					REF		REF= Sample Spoon Refusal
20	9	10	11			Grey Silty CLAY, some f-c Sand, tr. gravel (moist, v. stiff, CL- ML)	
		9	5		20		
20	10	3	3			Contains tr. sand (medium)	
		2	3		5		
25	11	4	3				
		2	3		5		
25	12	2	3				
		2	2		5		
25	13	3	3				
		3	3		6		
30	14	T	U	B	E		
30	15	1	2				
		2	4		4		
35	16	1	2				
		3	3		5		
35	17	3	4				
		3	4		7		
35	18	1	3				WOH= Weight of Hammer and Rods
		3	3		6		
40	19	T	U	B	E	(v. soft)	
40	20	WOH	WOH				No Free Standing Water Reading Obtained at Boring Completion
		1	2		1	Boring Complete at 40.0'	

N = NO. BLOWS TO DRIVE 2-INCH SPOON 12-INCHES WITH A 140 LB. PIN WT. FALLING 30-INCHES PER BLOW CLASSIFIED BY: Geologist  
 DRILLER: A. JAKUBCZAK DRILL RIG TYPE: CME- 75  
 METHOD OF INVESTIGATION ASTM D-1586 USING HOLLOW STEM AUGERS

DATE  
 START 8/13/2007  
 FINISH 8/13/2007  
 SHEET 1 OF 4

**SJB SERVICES, INC.**  
**SUBSURFACE LOG**



HOLE NO. B-3  
 SURF. ELEV. \_\_\_\_\_  
 G.W. DEPTH See Notes

PROJECT: REPLACEMENT OF TANNERY STREET BRIDGE LOCATION: OVER TRIBUTARY S. BR. CATT. CREEK  
 PROJ. NO.: BD-07-106 VILLAGE OF CATTARAUGUS, NY

DEPTH FT.	SMPL NO.	BLOWS ON SAMPLER				SOIL OR ROCK CLASSIFICATION	NOTES
		0/6	6/12	12/18	N		
5	1	4	7			Grey- Brown Silty Fine SAND, some Clay, tr. gravel (moist, stiff, CL- ML) possible FILL Contains some fine Gravel	No Recovery Sample #3  Installed 2- inch diameter PVC well to 130- feet, 30- feet screen, 100- feet riser with flush mount casing.
		5	6		12		
5	2	4	7			(medium)	
		7	6		14		
5	3	5	4			Possible FILL	
		3	3		7		
10	4	2	4			Grey Silty CLAY, some f-c Sand, little fine Gravel (moist, stiff, CL- ML)	
		3	3		7		
10	5	4	3			Contains tr. sand, tr. gravel	
		3	3		6		
15	6	2	3			(medium)	
		5	4		8		
15	7	3	5			(stiff)	
		4	4		9		
20	8	4	5			(medium)	
		7	6		12		
20	9	6	8			(stiff)	
		5	8		13		
25	10	2	3			(medium)	
		3	4		6		
25	11	3	4			(stiff)	
		5	5		9		
25	12	4	7			(medium)	
		6	7		13		
30	13	3	4			(stiff)	
		4	4		8		
30	14	T	U	B	E	(medium)	
35	15	2	3			(stiff)	
		3	3		6		
35	16	3	3			(medium)	
		5	7		8		
40	17	4	6			(stiff)	
		3	5		9		
40	18	3	3			(medium)	
		4	3		7		
40	19	T	U	B	E	(medium)	
40	20	3	2			(medium)	
		3	3		5		

N = NO. BLOWS TO DRIVE 2-INCH SPOON 12-INCHES WITH A 140 LB. PIN WT. FALLING 30-INCHES PER BLOW CLASSIFIED BY: Geologist  
 DRILLER: A. JAKUBCZAK DRILL RIG TYPE: CME- 75  
 METHOD OF INVESTIGATION ASTM D-1586 USING HOLLOW STEM AUGERS

DATE  
 START 8/13/2007  
 FINISH 8/13/2007  
 SHEET 2 OF 4

**SJB SERVICES, INC.**  
**SUBSURFACE LOG**



HOLE NO. B-3  
 SURF. ELEV. \_\_\_\_\_  
 G.W. DEPTH See Notes

PROJECT: REPLACEMENT OF TANNERY STREET BRIDGE LOCATION: OVER TRIBUTARY S. BR. CATT. CREEK  
 PROJ. NO.: BD-07-106 VILLAGE OF CATTARAUGUS, NY

DEPTH FT.	SMPL NO.	BLOWS ON SAMPLER				SOIL OR ROCK CLASSIFICATION	NOTES
		0/6	6/12	12/18	N		
45	21	WOH	1			(soft)	WOH= Weight of Hammer and Rods
		2	2		3		
50	22	1	1			(v. soft)	
		1	2		2		
55	23	WOH	WOH				
		WOH	1		0		
60	24	WOH	WOH				
		1	3		1		
65	25	WOH	WOH				
		1	4		1		
70	26	WOH	2			(medium)	
		3	5		5		
75	27	WOH	2				
		5	5		7		
80							

N = NO. BLOWS TO DRIVE 2-INCH SPOON 12-INCHES WITH A 140 LB. PIN WT. FALLING 30-INCHES PER BLOW CLASSIFIED BY: Geologist  
 DRILLER: A. JAKUBCZAK DRILL RIG TYPE: CME-75  
 METHOD OF INVESTIGATION ASTM D-1586 USING HOLLOW STEM AUGERS

DATE  
 START 8/13/2007  
 FINISH 8/13/2007  
 SHEET 3 OF 4

**SJB SERVICES, INC.**  
**SUBSURFACE LOG**



HOLE NO. B-3  
 SURF. ELEV. \_\_\_\_\_  
 G.W. DEPTH See Notes

PROJECT: REPLACEMENT OF TANNERY STREET BRIDGE LOCATION: OVER TRIBUTARY S. BR. CATT. CREEK  
 PROJ. NO.: BD-07-106 VILLAGE OF CATTARAUGUS, NY

DEPTH FT.	SMPL NO.	BLOWS ON SAMPLER				SOIL OR ROCK CLASSIFICATION	NOTES
		0/6	6/12	12/18	N		
80	28	WOH	1				
		3	3		4		
85	29	1	3				
		2	3		5		
90	30	WOH	WOH			(v. soft)	
		1	3		1		
95	31	1	1			(soft)	
		2	2		3		
100	32	WOH	1				
		2	2		3		
105	33	WOH	1				WOH= Weight of Hammer and Rods
		2	4		3		
110	34	WOH	1				
		3	3		4		
115	35	WOH	WOH			(v. soft)	
		1	2		1		
120							

N = NO. BLOWS TO DRIVE 2-INCH SPOON 12-INCHES WITH A 140 LB. PIN WT. FALLING 30-INCHES PER BLOW CLASSIFIED BY: Geologist  
 DRILLER: A. JAKUBCZAK DRILL RIG TYPE: CME- 75  
 METHOD OF INVESTIGATION ASTM D-1586 USING HOLLOW STEM AUGERS

DATE  
 START 8/13/2007  
 FINISH 8/13/2007  
 SHEET 4 OF 4

**SJB SERVICES, INC.**  
**SUBSURFACE LOG**



HOLE NO. B-3  
 SURF. ELEV. \_\_\_\_\_  
 G.W. DEPTH See Notes

PROJECT: REPLACEMENT OF TANNERY STREET BRIDGE LOCATION: OVER TRIBUTARY S. BR. CATT. CREEK  
 PROJ. NO.: BD-07-106 VILLAGE OF CATTARAUGUS, NY

DEPTH FT.	SMPL NO.	BLOWS ON SAMPLER				SOIL OR ROCK CLASSIFICATION	NOTES
		0/6	6/12	12/18	N		
/	36	WOH	1			(wet)	WOH= Weight of Hammer and Rods
		WOH	3		1		
125	/	37	1	3		(medium)	
			4	3			
130	/	38	2	3			
			4	4			
135						Boring Complete at 132.0'	Free Standing Water Encountered at 70.0' at Boring Completion
140							
145							
150							
155							
160							

N = NO. BLOWS TO DRIVE 2-INCH SPOON 12-INCHES WITH A 140 LB. PIN WT. FALLING 30-INCHES PER BLOW CLASSIFIED BY: Geologist  
 DRILLER: A. JAKUBCZAK DRILL RIG TYPE: CME- 75  
 METHOD OF INVESTIGATION ASTM D-1586 USING HOLLOW STEM AUGERS

DATE  
 START 8/15/2007  
 FINISH 8/15/2007  
 SHEET 1 OF 1

**SJB SERVICES, INC.**  
**SUBSURFACE LOG**



HOLE NO. B-4  
 SURF. ELEV. \_\_\_\_\_  
 G.W. DEPTH See Notes

PROJECT: REPLACEMENT OF TANNERY STREET BRIDGE LOCATION: OVER TRIBUTARY S. BR. CATT. CREEK  
 PROJ. NO.: BD-07-106 VILLAGE OF CATTARAUGUS, NY

DEPTH FT.	SMPL NO.	BLOWS ON SAMPLER				SOIL OR ROCK CLASSIFICATION	NOTES
		0/6	6/12	12/18	N		
	1	-	3			Brown f-c SAND, some fine Gravel, some Silty Clay (moist, loose, SM)	
		4	4		7		
	2	3	3				
		4	4		7		
5	3	4	3			Brown Silty CLAY, little f-c Sand, little fine Gravel (moist, medium, CL- ML)	
		2	2		5		
	4	3	4			Contains tr. sand, tr. gravel	
		4	3		8		
	5	3	3			Becomes Grey	
		3	4		6		
10	6	3	3			Contains little f-c Sand	
		3	4		6		
	7	3	2				
		2	3		4		
15	8	3	5			Contains tr. sand (stiff)	
		5	7		10		
	9	5	5				
		7	8		12		
20	10	4	6				
		6	9		12		
	11	4	3			(medium)	
		2	3		5		
	12	4	3				
		3	3		6		
25	13	3	4				
		3	3		7		
	14	T	U	B	E		
30	15	3	2				
		2	3		4		
	16	WOH	1			(soft)	WOH= Weight of Hammer and Rods
		2	4		3		
	17	4	4			(stiff)	
		5	5		9		
35	18	WOH	WOH			(v. soft)	
		1	2		1		
	19	T	U	B	E	(medium)	
40	20	3	4			Boring Complete at 40.0'	No Free Standing Water Reading Obtained at Boring Completion
		4	3		8		

N = NO. BLOWS TO DRIVE 2-INCH SPOON 12-INCHES WITH A 140 LB. PIN WT. FALLING 30-INCHES PER BLOW CLASSIFIED BY: Geologist  
 DRILLER: A. JAKUBCZAK DRILL RIG TYPE: CME- 75  
 METHOD OF INVESTIGATION ASTM D-1586 USING HOLLOW STEM AUGERS



**Fax Transmittal**


**Date:** May 15, 2009  
**To:** STANTEC  
**Att:** Barbara Wagner  
**Pages:** 9  
**Fax No.:** 585.424.5951  
**From:** Barb Kent

Subsurface Logs & Well Installation Records  
for Tannery Road Bridge Project

Please call with questions or concerns

If you did not receive all pages – or if the quality is not suitable, please call  
SJB SERVICES, INC. 5167 SOUTH PARK AVENUE, HAMBURG, NY 716-649-8110(P), 716-649-8051 (F)



DATE START <u>4/21/2009</u> FINISH <u>4/22/2009</u> SHEET <u>1</u> OF <u>3</u>	<b>SJB SERVICES, INC.</b> <b>SUBSURFACE LOG</b>	 HOLE NO. <u>B-5</u> SURF. ELEV. _____ G.W. DEPTH <u>See Notes</u>
---	--	---

PROJECT: <u>TANNERY ROAD BRIDGE</u> PROJ. NO.: <u>BD-09-048</u>	LOCATION: <u>TANNERY ROAD</u> <u>CATTARAUGUS, NY</u>
--	---

DEPTH FT.	SMPL NO.	BLOWS ON SAMPLER				SOIL OR ROCK CLASSIFICATION	NOTES
		0/6	6/12	12/18	N		
	1	2	2			Brown f-c GRAVE, some f-c Sand, tr. silt, occasional Silty Clay Partings (moist, FILL)	
		7	10		9		
	2	10	6			Gray Silty CLAY, tr. sand, occasional f-m Sand Partings (moist, stiff, CL, possible FILL)	
		6	5		12		
5	3	4	3			Becomes Brown. Contains occasional f-c Sand Seams (medium)	
		2	2		5		
	4	3	3			Contains and f-c GRAVEL, little f-c Sand	
		3	2		6		
	5	3	3			Light Brown to Tan Silty CLAY, tr. sand (moist, medium, CL)	
		2	2		5		
10	6	2	2			Becomes Brown Gray, Contains tr. gravel, occasional f-c Sand Seams	
		2	3		4		
	7	3	3			Dark Gray f-m SAND, some Silt, tr. clay, tr. wood, occasional Silty lay laminations (moist, loose, SM)	
		3	3		6		
15	8	WH	WH			Dark Gray Silty CLAY, little f. Sand, tr. roots (moist, very soft, CL)	
		WH	2		WH		
	9	2	2			Becomes Gray, contains tr. sand (soft)	
		2	3		4		
20	10	1	2			Contains tr. gravel, tr. wood, occasional Silt partings  (medium)	
		2	3		4		
	11	2	2				
		2	4		6		
	12	3	3				
		4	5		7		
25	13	WH	WH			(very soft)	
		2	3		2		
	14	4	4			(medium)	
		4	5		8		
30	15	1	1				
		1	1		2		
	16	2	2			Becomes Brown Gray (medium)	
		3	3		5		
	17	3	4				
		4	4		8		
35	18	3	3				
		4	5		7		
	19	4	4			Contains frequent Silt partings	
		4	4		8		
40	20	3	3				
		4	4		7		

N = NO. BLOWS TO DRIVE 2-INCH SPOON 12-INCHES WITH A 140 LB. PIN WT. FALLING 30-INCHES PER BLOW CLASSIFIED BY: Geologist  
 DRILLER: K. FULLER DRILL RIG TYPE: CME-550X  
 METHOD OF INVESTIGATION: ASTM D-1566 USING HOLLOW STEM AUGERS

DATE START <u>4/21/2009</u> FINISH <u>4/22/2009</u> SHEET <u>2</u> OF <u>3</u>	<b>SJB SERVICES, INC.</b> <b>SUBSURFACE LOG</b>	 HOLE NO. <u>B-5</u> SURF. ELEV. _____ G.W. DEPTH <u>See Notes</u>
---	--	---

PROJECT: <u>TANNERY ROAD BRIDGE</u> PROJ. NO.: <u>BD-09-048</u>	LOCATION: <u>TANNERY ROAD</u> <u>CATTARAUGUS, NY</u>
--	---

DEPTH FT.	SMPL NO.	BLOWS ON SAMPLER				SOIL OR ROCK CLASSIFICATION	NOTES
		3/8	5/12	12H#	N		
45	21	3	3				
		4	3		7		
45	22	3	3				
		4	4		7		
45	23	4	4				Driller Collected Shelby Tube from 46' to 48'
		4	4		8		
50	24	WH	WH		WH	(very soft)	
		WH	WH				
50	25	WH	WH			Contains occasional Silt partings	
		2	2		2		
55	26	4	4			(stiff)	
		5	5		9		
55	27	WH	WH			(very soft)	
		WH	WH		WH		
55	28	1	1			(soft)	
		2	2		3		
60	29	WH	WH			(very soft)	
		1	1		1		
60	30	1	3			(medium)	
		5	2		8		
65	31	2	5				
		3	4		8		
65	32	WH	1				
		5	4		6		
65	33	6	7			(stiff)	Driller Noted finish Drilling for April 21, 2009 at 68'
		7	9		14		
70	34	WH	WH			(very soft)	No Free Standing Water Encountered
		WH	3		WH		
70	35	WH	WH				Driller Collected Shelby Tube from 70' to 72'
		WH	3		WH		
75	36	2	2				
		2	2		4		
75	37	1	2			(soft)	
		2	2		4		
80	38	WH	2				
		2	1		4		

N = NO. BLOWS TO DRIVE 2-INCH SPOON 12-INCHES WITH A 140 LB PIN WT. FALLING 30-INCHES PER BLOW CLASSIFIED BY: Geologist  
 DRILLER: K. FULLER DRILL RIG TYPE CME-550X  
 METHOD OF INVESTIGATION ASTM D-1566 USING HOLLOW STEM AUGERS

DATE START <u>4/21/2009</u> FINISH <u>4/22/2009</u> SHEET <u>3 OF 3</u>	<b>SJB SERVICES, INC.</b> <b>SUBSURFACE LOG</b>	<div style="text-align: center;"></div> HOLE NO. <u>B-5</u> SURF. ELEV. _____ G.W. DEPTH <u>See Notes</u>
--	--	---

PROJECT: <u>TANNERY ROAD BRIDGE</u> PROJ. NO.: <u>BD-09-048</u>	LOCATION: <u>TANNERY ROAD</u> <u>CATTARAUGUS, NY</u>
--	---

DEPTH FT.	SMPL NO.	BLOWS ON SAMPLER				SOIL OR ROCK CLASSIFICATION	NOTES
		0/6	0/12	12/18	N		
85	39	2	3			(medium)	Driller Collected Shelby Tube from 80' to 82'  1" PVC Monitoring Well Installed at 84.0'
		2	5		5		
	40	1	4				
		7	8		11		
						Boring Complete at 86.0'	

N = NO. BLOWS TO DRIVE 2-INCH SPOON 12-INCHES WITH A 140 LB. PIN WT FALLING 30-INCHES PER BLOW CLASSIFIED BY: Geologist

DRILLER K. FULLER DRILL RIG TYPE: CME-550X


METHOD OF INVESTIGATION ASTM D-1586 USING HOLLOW STEM AUGERS

DATE START <u>4/23/2009</u> FINISH <u>4/24/2009</u> SHEET <u>1</u> OF <u>2</u>	<b>SJB SERVICES, INC.</b> <b>SUBSURFACE LOG</b> 	HOLE NO. <u>B-6</u> SURF. ELEV. _____ G.W. DEPTH <u>See Notes</u>
---	--	---

PROJECT: <u>TANNERY ROAD BRIDGE</u> PROJ. NO.: <u>BD-09-048</u>	LOCATION: <u>TANNERY ROAD</u> <u>CATTARAUGUS, NY</u>
--	---

DEPTH FT.	SAMPL NO.	BLOWS ON SAMPLER				SOIL OR ROCK CLASSIFICATION	NOTES
		0/8	6/12	12/18	N		
	1	11	10			BLACKTOP (2")	
		4	12		14	Brown f-c GRAVEL and f-c Sand, tr. silt (most FILL)	
	2	9	10			Contains tr. glass	
		5	5		15		
5	3	6	6				
		3	2		9		
	4	2	2			Brown to Gray Silty CLAY, tr. sand, tr. roots (moist, soft, CL, possible FILL)	Poor Recovery Sample No. 4
		2	2		4	Becomes Gray, little fine Gravel, little f-c Sand	
10	5	2	2				
		1	2		3		
	6	1	2			Contains f-c Gravel Seam	
		3	3		5		
	7	4	4			Gray Silty CLAY, tr. gravel, tr. sand, occasional f-c Sand Seams (moist, medium, CL)	
		4	5		8		
15	8	3	5			Brown f-m SAND, some Silt, tr. gravel, occasional Silty Clay laminations (moist-wet, firm SM)	Driller Noted finish Drilling for April 23, 2009 at 14.0'
		7	6		12	Becomes Gray f-c SAND, some Silt, little f-c Gravel (SW)	No Free Standing Water Encountered
	9	7	6				Poor Recovery Sample No. 9
		6	6		12		
20	10	2	2			Brown Gray Silty CLAY, tr. sand (moist, medium CL)	
		2	3		4		
	11	2	4			Contains tr. gravel, contains occasional silt partings	
		4	6		8	(stiff)	
	12	5	6				
		6	6		12		
25	13	WH	3			(medium)	
		3	3		6		
	14	3	4				
		5	5		9		
30	15	WH	WH			(soft)	Driller Collected Shelby Tube from 28.0' to 30.0'
		2	2		2		
	16	2	2				
		2	2		4		
35	17	WH	WH			(very soft)	
		WH	2		WH		
	18	WH	WH				
		WH	1		WH		
40	19	WH	WH				
		WH	2		WH		

N = NO BLOWS TO DRIVE 2-INCH SPOON 12-INCHES WITH A 140 LB. PIN WT FALLING 30-INCHES PER BLOW CLASSIFIED BY Geologist  
 DRILLER: K. FULLER DRILL RIG TYPE: CME-550X  
 METHOD OF INVESTIGATION ASTM D-1586 USING HOLLOW STEM AUGERS

DATE START <u>4/23/2009</u> FINISH <u>4/24/2009</u> SHEET <u>2</u> OF <u>2</u>	<b>SJB SERVICES, INC.</b> <b>SUBSURFACE LOG</b>	 HOLE NO. <u>B-6</u> SURF. ELEV. _____ G.W. DEPTH <u>See Notes</u>
---	--	---

PROJECT: <u>TANNERY ROAD BRIDGE</u> PROJ. NO.: <u>BD-09-048</u>	LOCATION: <u>TANNERY ROAD</u> <u>CATTARAUGUS, NY</u>
--	---

DEPTH FT.	BMPL NO.	BLOWS ON SAMPLER				SOIL OR ROCK CLASSIFICATION	NOTES
		0/8	0/12	12/15	N		
	20	WH	1			(moist-wet, soft)	
			3	3		4	
	21		3	4		(stiff)	
			5	6		9	
45	22		1	1		Becomes Gray (soft)	
			1	1		2	
	23		1	1			
			1	1		2	
	24		3	1			
			1	1		2	
50	25	WH	2			(moist, medium)	
			3	5		5	
	26		2	3			
			3	5		6	
55							Driller Collected Shelby Tube from 54.0' to 56.0'
	27	WH	1				
			3	4		4	
	28	WH	2			Contains occasional Silt Seams	
			2	3		4	
60	29	WH	2				
			2	3		4	
65	30	WH	2			(soft)	Driller Collected Shelby Tube from 62.0' to 64.0'
			1	3		3	
Boring Complete at 66.0'							1" PVC Monitoring Well Installed at 65.0'
70							
75							
80							

N = NO. BLOWS TO DRIVE 2-INCH SPOON 12-INCHES WITH A 140 LB. PIN WT. FALLING 30-INCHES PER BLOW CLASSIFIED BY: Geologist  
 DRILLER: K. FULLER DRILL RIG TYPE: CME-550X  
 METHOD OF INVESTIGATION ASTM D-1586 USING HOLLOW STEM AUGERS

DATE START <u>4/23/2009</u> FINISH <u>4/23/2009</u> SHEET <u>1 OF 1</u>	<b>SJB SERVICES, INC.</b> <b>SUBSURFACE LOG</b> 	HOLE NO. <u>B-7</u> SURF. ELEV. _____ G.W. DEPTH <u>See Notes</u>
--	--	---

PROJECT: TANNERY ROAD BRIDGE LOCATION: TANNERY ROAD  
 PROJ. NO.: BD-09-048 CATTARAUGUS, NY

DEPTH FT	SMPL NO.	BLOWS ON SAMPLER				SOIL OR ROCK CLASSIFICATION	NOTES
		0/6	6/12	12/18	N		
	1	2	2			TOPSOIL (2")	
	2	2			4	Brown f-c SAND, little f. Gravel, little Silt (moist, FILL)	
	2	4	3			Brown f-c GRAVEL, little f-c Sand, little Silt	
		2	2		5	occasional Silty Clay laminations (moist, FILL)	
5	3	2	2			Brown Silty CLAY, tr. sand, tr. roots,	
		2	2		4	(moist, medium, CL possible FILL)	
	4	15	8			Contains some f-c Gravel, little f-c Sand,	
		4	4		12	tr. organics (stiff)	
	5	2	2			Brown Silty CLAY, tr. sand (medium)	
10		3	4		5		
	6	2	2			Becomes Gray, contains occasional fine Sand	
		2	2		4	and Silty Seams	
	7	3	3				
		3	3		6	Contains occasional Silt Seams	
15	8	3	3				
		3	4		7		
	9	4	4				
		4	5		8		
	10	2	2			Becomes Brown Gray	
20		2	3		4		
	11	WH	2			Contains occasional Silt partings	
		2	4		4		
	12	4	4				
		4	5		8		
25	13	WH	1				
		3	3		4		
	14	3	4				
		4	5		8		
	15	1	1				
30		3	4		4		1" PVC Monitoring Well Installed at 40.0'
	16	WH	3				
		3	15		6		
	17	4	4				
		4	5		8		
35							Driller Collected Shelby Tube from 34.0' to 36.0'
	18	3	4				
		4	4		8		
40						Boring Complete at 40.0'	Driller Collected Shelby Tube from 38.0' to 40.0'

N = NO. BLOWS TO DRIVE 2-INCH SPOON 12-INCHES WITH A 140 LB. PIN WT. FALLING 30-INCHES PER BLOW CLASSIFIED BY: Geologist  
 DRILLER K. FULLER DRILL RIG TYPE: CME-550X  
 METHOD OF INVESTIGATION ASTM D-1586 USING HOLLOW STEM AUGERS

**MONITORING WELL COMPLETION RECORD**



<b>PROJECT:</b> Tannery Road Bridge	
<b>PROJECT NUMBER:</b> BD - 09- 048	<b>DRILLING METHOD:</b> 3 1/4 HAS
<b>WELL NUMBER:</b> B-5	<b>GEOLOGIST:</b>
<b>DRILLER:</b> K. Fuller	<b>INSTALLATION DATE(S):</b> 4/22/2009



**TYPE OF SURFACE SEAL:** Portland Type I Cement

**TYPE OF BACKFILL:** Soil Cuttings

**BOREHOLE DIAMETER:** 7"

**I.D. OF RISER PIPE:** 1"

**TYPE OF RISER PIPE:** PVC Schedule 40

**DEPTH OF SEAL:** 69.0'

**TYPE OF SEAL:** Bentonite Chlps

**DEPTH OF SAND PACK:** 72.0'

**DEPTH OF TOP OF SCREEN:** 74.0'

**TYPE OF SCREEN:** PVC Schedule 40

**SLOT SIZE X LENGTH:** 0.10" x 10"

**I.D. OF SCREEN:** 1"

**TYPE OF SAND PACK:** Silica Sand No. 0

**DEPTH BOTTOM OF SCREEN:** 84.0'

**DEPTH BOTTOM OF SAND PACK:** 85.0'

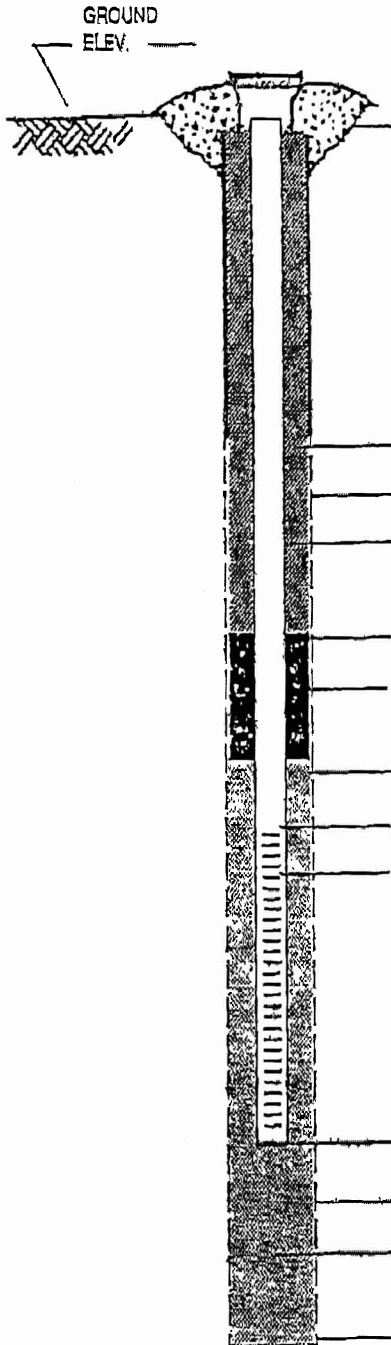
**TYPE OF BACKFILL BELOW OBSERVATION WELL:** Native Soils

**ELEVATION/ DEPTH OF HOLE:** 85.0'

**MONITORING WELL COMPLETION RECORD**



<b>PROJECT:</b> Tannery Road Bridge	
<b>PROJECT NUMBER:</b> BD - 09- 048	<b>DRILLING METHOD:</b> 3 1/4 HAS
<b>WELL NUMBER:</b> B-6	<b>GEOLOGIST:</b>
<b>DRILLER:</b> K. Fuller	<b>INSTALLATION DATE(S):</b> 4/24/2009



**TYPE OF SURFACE SEAL:**  
Portland Type I Cement

**TYPE OF BACKFILL:** Soil Cuttings  
**BOREHOLE DIAMETER:** 7"  
**I.D. OF RISER PIPE:** 1"  
**TYPE OF RISER PIPE:** PVC Schedule 40

**DEPTH OF SEAL:** 49.0'  
**TYPE OF SEAL:** Bentonite Chips

**DEPTH OF SAND PACK:** 52.0'  
**DEPTH OF TOP OF SCREEN:** 55.0'

**TYPE OF SCREEN:** PVC Schedule 40  
**SLOT SIZE X LENGTH:** 0.10" x 10"  
**I.D. OF SCREEN:** 1"  
**TYPE OF SAND PACK:** Silica Sand No. 0

**DEPTH BOTTOM OF SCREEN:** 65.0'

**DEPTH BOTTOM OF SAND PACK:** 65.0'

**TYPE OF BACKFILL BELOW OBSERVATION WELL:**  
Native Soils

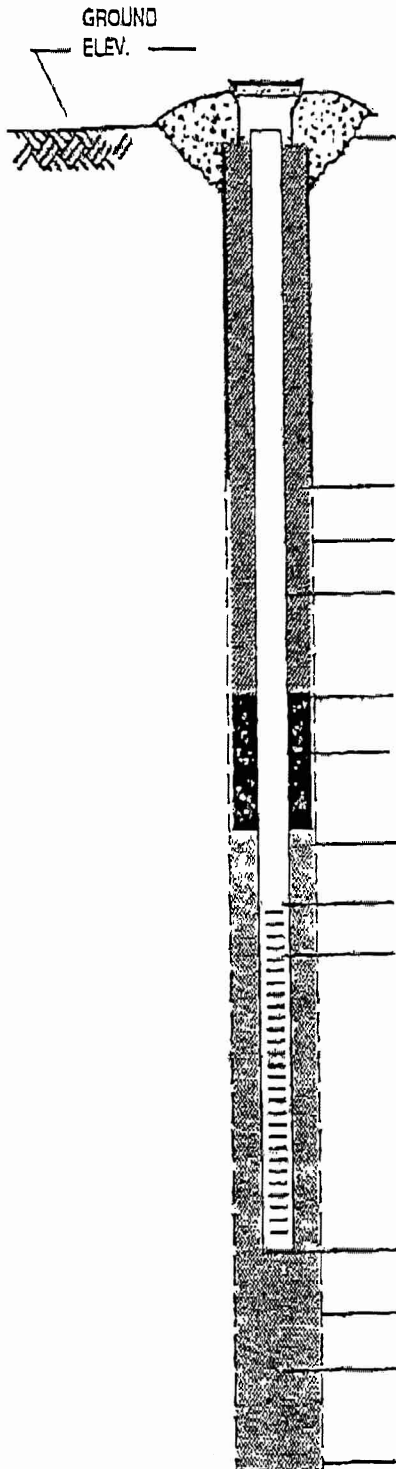
**ELEVATION/ DEPTH OF HOLE:** 65.0'



**MONITORING WELL COMPLETION RECORD**



<b>PROJECT:</b> Tannery Road Bridge	
<b>PROJECT NUMBER:</b> BD - 09- 048	<b>DRILLING METHOD:</b> 3 1/4 HAS
<b>WELL NUMBER:</b> B-7	<b>GEOLOGIST:</b>
<b>DRILLER:</b> K. Fuller	<b>INSTALLATION DATE(S):</b> 4/23/2009



**TYPE OF SURFACE SEAL:**  
 Portland Type I Cement

**TYPE OF BACKFILL:** Soil Cuttings

**BOREHOLE DIAMETER:** 7"

**I.D. OF RISER PIPE:** 1"

**TYPE OF RISER PIPE:** PVC Schedule 40

**DEPTH OF SEAL:** 24.0'

**TYPE OF SEAL:** Bentonite Chips

**DEPTH OF SAND PACK:** 27.0'

**DEPTH OF TOP OF SCREEN:** 30.0'

**TYPE OF SCREEN:** PVC Schedule 40

**SLOT SIZE X LENGTH:** 0.10" x 10"

**I.D. OF SCREEN:** 1"

**TYPE OF SAND PACK:** Silica Sand No. 0

**DEPTH BOTTOM OF SCREEN:** 40.0'

**DEPTH BOTTOM OF SAND PACK:** 40.0'

**TYPE OF BACKFILL BELOW OBSERVATION WELL:**  
 Native Soils

**ELEVATION/ DEPTH OF HOLE:** 40.0'

**This Page Left Intentionally Blank**

**NYSDEC Water Quality Certification**  
**Letter**

**This Page Left Intentionally Blank**

**NEW YORK STATE DEPARTMENT OF ENVIRONMENTAL CONSERVATION**

Division of Environmental Permits, Region 9  
182 East Union, Suite 3, Allegany, NY 14706-1328  
P: (716) 372-0645 | F: (716) 372-2113  
www.dec.ny.gov

May 2, 2019

Mark C. Burr, P.E.  
Cattaraugus County Dept. of Public Works  
8810 NYS Route 242  
Little Valley, New York 14755

**REPLACEMENT OF NEW ALBION BRIDGE #35 (BIN 3322810)  
TANNERY STREET OVER TRIBUTARY 7 OF SOUTH BRANCH OF  
CATTARAUGUS CREEK  
(V) OF CATTARAUGUS, (T) NEW ALBION CATTARAUGUS CO.  
DEC ID: 9-0464-00027/00003**

Dear Mr. Burr:

This will acknowledge receipt of your application for a permit and advise you that, pursuant to the provisions of N.Y.S. Environmental Conservation Law, no Department Stream Disturbance nor Freshwater Wetlands permit has been identified for the above-noted work in accordance with the submitted plans.

This letter also affirms that Section 401 Water Quality Certification has already been granted by this Department and that the subject project will not contravene effluent limitations or other limitations or standards under Sections 301, 302, 303, 306 and 307 of the Clean Water Act of 1977 (PL 95-217) for activities carried out under U.S. Dept. of Army, Corps of Engineers' Nationwide Permit No. 3.

This determination does not, however, relieve you of any requirements under any other applicable laws which may exist. In particular, you are specifically reminded that project activities (either directly or indirectly) cannot cause contravention of water quality standards. **Therefore, appropriate soil and erosion control measures must be utilized during construction to prevent the movement of turbid waters from the project site.** In addition, you are advised to contact all appropriate Federal, State and/or local agencies for any approvals that may be required.

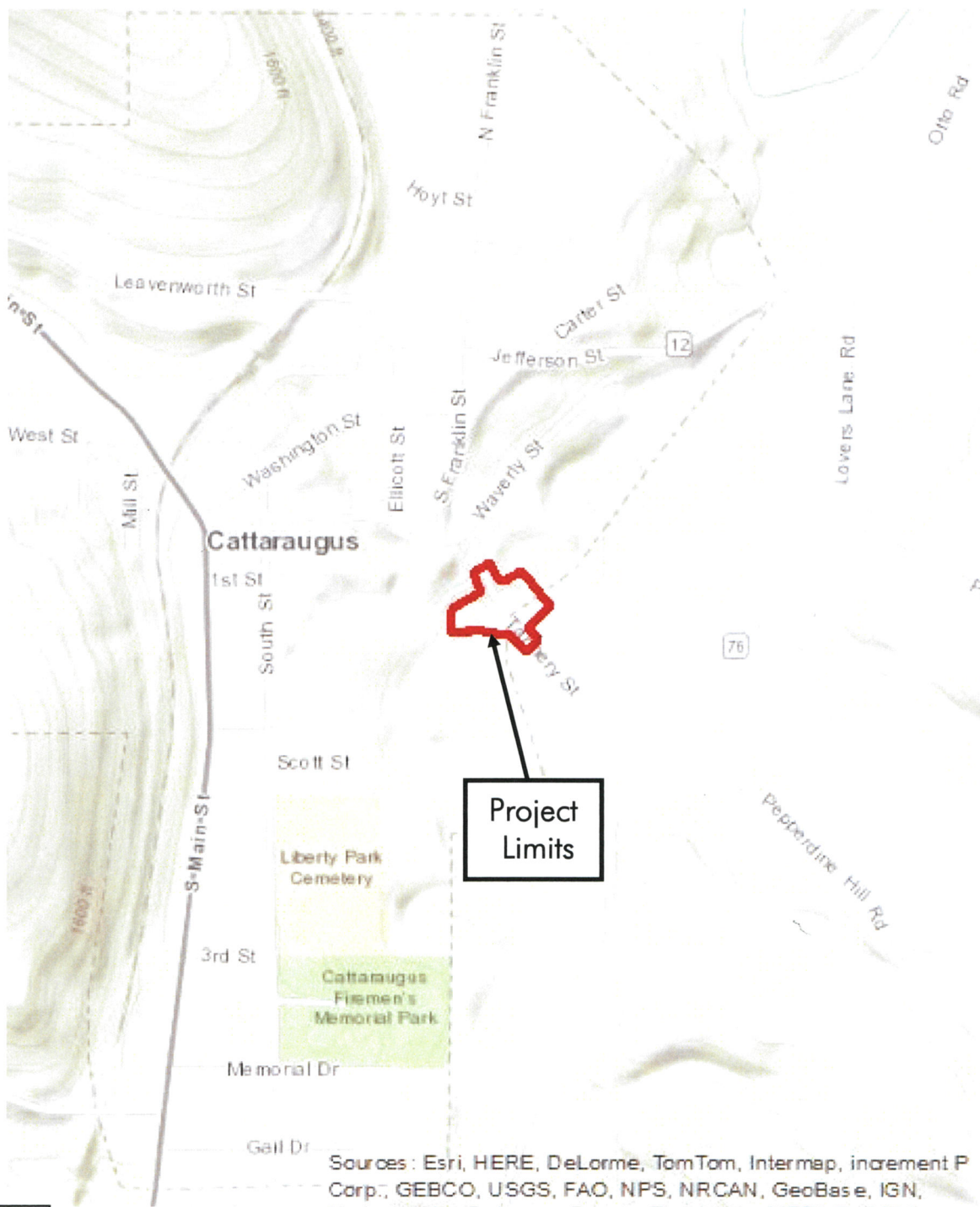
If you have any questions or comments in regard to this letter, or your responsibilities under the New York State Environmental Conservation Law, please do not hesitate to contact this office.

Sincerely,

Charles D. Cranston  
Deputy Regional Permit Administrator

cc: Capt. Elizabeth Haag, NYSDEC Division of Law Enforcement  
U.S. Department of Army, Buffalo District Corps of Engineers  
Ms. Virginia Ursitti, QEP, Watts Architecture & Engineering





Sources: Esri, HERE, DeLorme, TomTom, Intermap, increment P Corp., GEBCO, USGS, FAO, NPS, NRCAN, GeoBase, IGN, Kadaster NL, Ordnance Survey, Esri Japan, METI, Esri China (Hong Kong), swisstopo, MapmyIndia, © OpenStreetMap contributors, and the GIS User Community

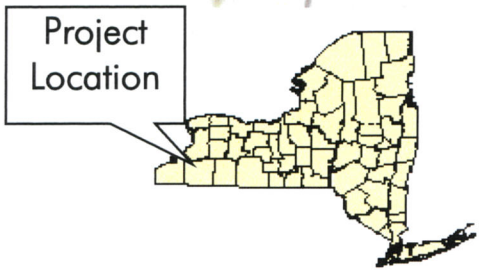


Figure 1 - Project Location Map

Tannery Street Bridge over Tributary to  
Cattaraugus Creek  
Cattaraugus, New York

Not to Scale

February 13, 2018



**Watts Architecture &  
Engineering**  
95 Perry Street  
Buffalo, New York

# **USACE PERMIT**

**This Page Left Intentionally Blank**





**DEPARTMENT OF THE ARMY**  
BUFFALO DISTRICT, CORPS OF ENGINEERS  
1776 NIAGARA STREET  
BUFFALO, NEW YORK 14207-3199

June 18, 2019

Regulatory Branch

SUBJECT: Application No. LRB-2019-00398, Nationwide Permit No. 3 as Published in the Federal Register, Volume 82, No. 4, on Friday, January 6, 2017

Mr. William Fox, P.E.  
Cattaraugus County Department of Public Works  
8810 Route 242  
Little Valley, New York 14755

Dear Mr. Fox:

This pertains to your application for a Department of the Army permit to replace the existing three, side-by-side 12-foot diameter by 48-foot long culverts with a 32-foot by 72-foot three-sided concrete box culvert and place a total of 3,179 cubic yards of fill (including concrete, heavy stone, bedding material and granular fill) into an unnamed tributary to support the new culvert, replacement of the concrete waterfall with new grade control, and to improve the existing plunge pool, located at Tannery Street over unnamed tributary to South Branch Cattaraugus Creek, Town of Cattaraugus, Cattaraugus County, New York.

I have evaluated the impacts associated with your proposal, and have concluded that they are authorized by the enclosed Nationwide Permit (NWP) provided that the attached conditions are satisfied.

Verification of the applicability of this NWP is valid until March 18, 2022 unless the NWP is modified, suspended, revoked, or the activity complies with any subsequent permit modification. Please note in accordance with 33 CFR part 330.6(b), that if you commence or are under contract to commence an activity in reliance of the permit prior to the date this NWP expires, is suspended or revoked, or is modified such that the activity no longer complies with the terms and conditions, you have twelve months from the date of permit modification, expiration, or revocation to complete the activity under the present terms and conditions of the permit, unless the permit has been subject to the provisions of discretionary authority.

It is your responsibility to remain informed of changes to the NWP program. A public notice announcing any changes will be issued when they occur and will be available for viewing at our website: <http://www.lrb.usace.army.mil/Missions/Regulatory.aspx>. Finally, note that if your activity is not undertaken within the defined period or the project specifications have changed, you must immediately notify this office to determine the need for further approval or reverification.

Regulatory Branch

SUBJECT: Application No. LRB-2018-00844, Nationwide Permit No. 13 as Published in the Federal Register, Volume 82, No. 4, on Friday, January 6, 2017

During our review we considered all applicable Federal requirements as well as state Water Quality Certification (WQC) conditions. We have made every effort to ensure that your project complies with these requirements. However, we have neither the resources nor the statutory authority to conclusively determine whether your project complies with ALL New York State WQC conditions. In this regard, I strongly suggest that you closely review the WQC conditions attached at the end of this document. If you are certain that you will remain in compliance with ALL conditions attached to this Permit no further coordination is required. However, if you have any doubt about your ability to comply with the state WQC conditions you must resolve those issues with the appropriate Department of Environmental Conservation (DEC) Regional office before you commence work. If the state determines that you need to obtain a project specific WQC you should forward to this office a copy of their final decision at the conclusion of the process. Direct your WQC inquiries to:

Regional Permit Administrator  
New York State Department of Environmental Conservation  
270 Michigan Avenue  
Buffalo, NY 14203-2999

Your initiation of work as authorized by the enclosed NWP acknowledges your acceptance of the general and special conditions contained therein. This affirmation is limited to the attached NWP and associated WQC, and does not obviate the need to obtain any other project specific Federal, state, or local authorization. Specifically, you may need to obtain Article 15 (Protection of Water), Article 24 (Freshwater Wetland), and/or Article 34 (Coastal Erosion Management) authorization from the New York State DEC.

Questions pertaining to this matter should be directed to me at 716-879-4308, by writing to the following address: U.S. Army Corps of Engineers, 1776 Niagara Street, Buffalo, New York 14207, or by e-mail at: Heather.L.Adams@usace.army.mil

Sincerely,



Heather Adams  
Biologist

Enclosures

COMPLETION FORM / COMPLIANCE CERTIFICATION

Each permittee who receives a Nationwide Permit (NWP) verification letter from the Corps must provide a signed certification documenting completion of the authorized activity and any compensatory mitigation.

APPLICANT:	POINT OF CONTACT:	File No.: LRB-2019-00398
William Fox	Virginia Ursitti	File Closed: 6/18/2019
Cattaraugus County DPW	Watts Architecture &	NWP No.: 3
8810 Route 242	Engineering	
Little Valley, New York 14755	95 Perry Street, Suite 300	
	Buffalo, New York 14203	

**Upon completion of the activity authorized by this permit and any required compensatory mitigation sign this certification and return it to the address listed below within 30 days of project completion.**

Please note that your permitted activity is subject to a compliance inspection by a U.S. Army Corps of Engineers representative. If you fail to comply with this permit you are subject to permit suspension, modification, revocation, and/or assessment of administrative penalties.

The permittee shall certify the completion of the authorized work and mitigation:

- a. The authorized work was done in accordance with the NWP authorization, including any general, regional, or activity specific conditions.
- b. The implementation of any required compensatory mitigation was completed in accordance with the permit conditions. If credits from a mitigation bank or in-lieu fee program are used to satisfy the compensatory mitigation requirements, this certification must include the documentation required by 33 CFR 332.3(1)(3) to confirm that the permittee secured the appropriate number and resource type of credits.

\_\_\_\_\_  
APPLICANTS NAME

\_\_\_\_\_  
Date

Permittee Telephone Number: \_\_\_\_\_

Department of the Army permit to replace the existing three, side-by-side 12-foot diameter by 48-foot long culverts with a 32-foot by 72-foot three sided concrete box culvert and place a total of 3,179 cubic yards of fill (including concrete, heavy stone, bedding material and granular fill) into an unnamed tributary to support the new culvert, replacement of the concrete waterfall with new grade control, and to improve the existing plunge pool, located at Tannery Street over unnamed tributary to South Branch Cattaraugus Creek, Town of Cattaraugus, Cattaraugus County, New York.

Return completed form to:  
**Mr. David Leput**  
**Regulatory Branch**  
**U.S. Army Corps of Engineers**  
**1776 Niagara Street**  
**Buffalo, NY 14207**

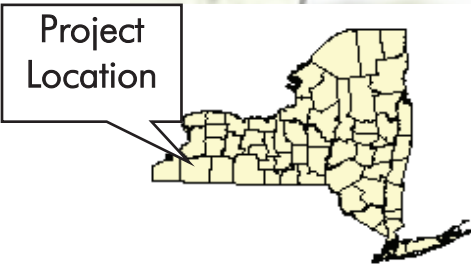


Figure 1 - Project Location Map

Tannery Street Bridge over Tributary to  
Cattaraugus Creek  
Cattaraugus County DPW

LRB-2019-00398  
Sheet 1 of 21 **136**

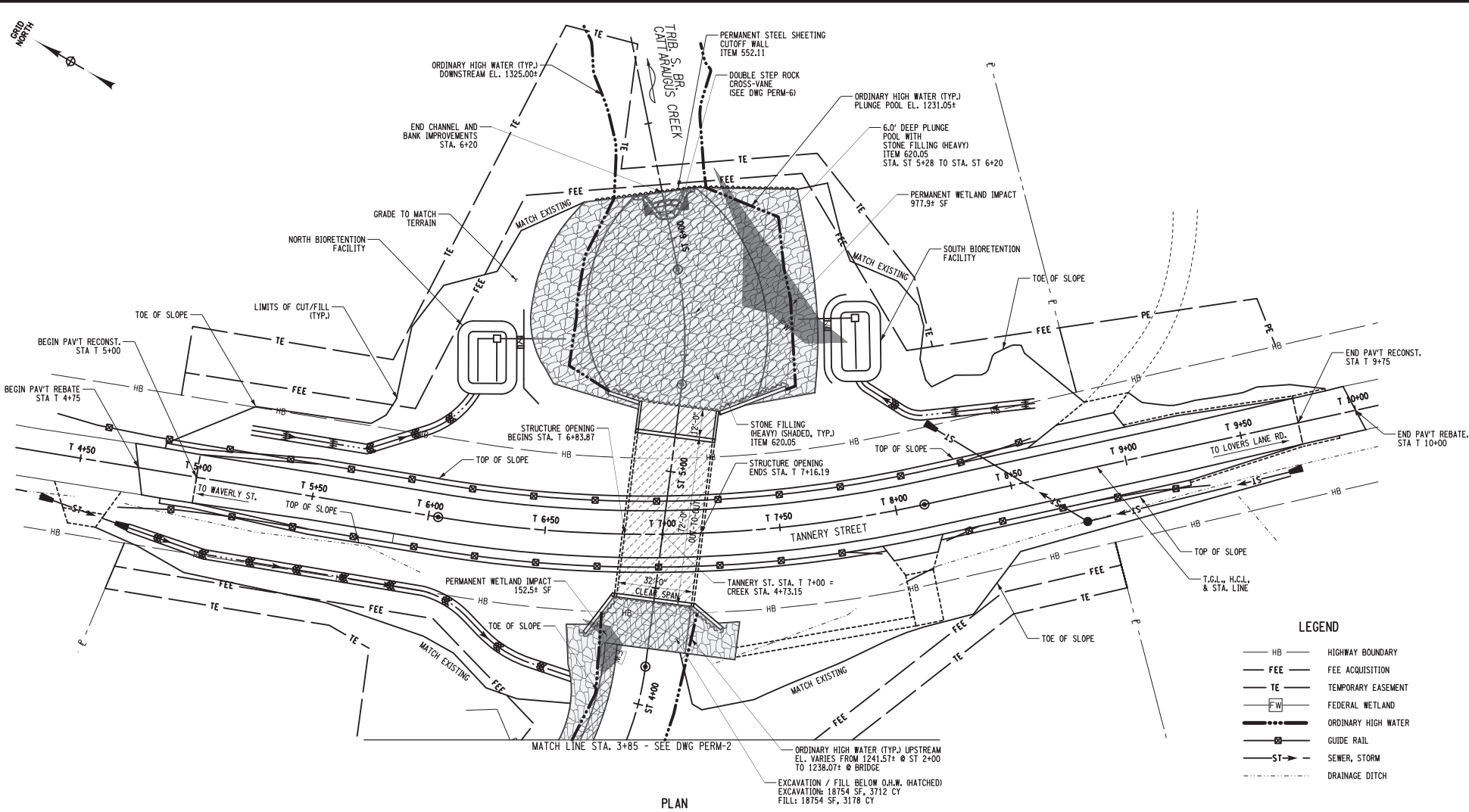
Not to Scale



Watts Architecture &  
Engineering  
95 Perry Street  
Buffalo, New York

FILE NAME = L:\19250012\environmental\Permits\Permit Drawings\PERM-1.dgn  
 DATE/TIME = 3/10/2019 2:05:48 PM  
 USER = koberis

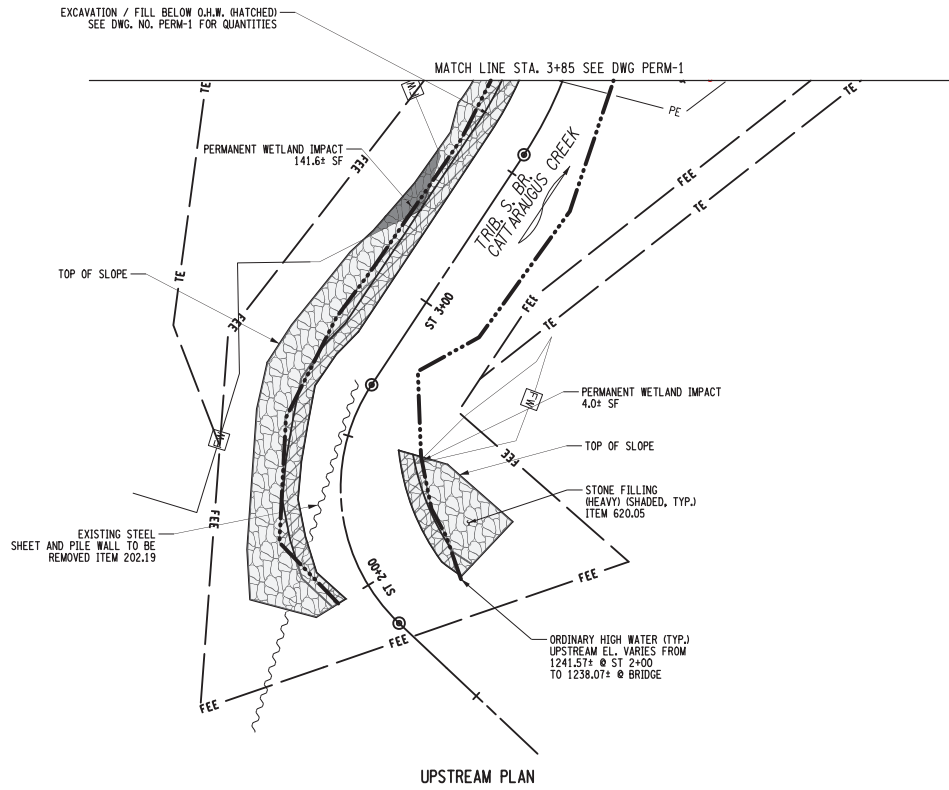
DESIGN SUPERVISOR T. BRADLEY JOB MANAGER S. MILLER/T. BRADLEY DESIGN D. CLARK DRAFTING D. CLARK CHECK T. BRADLEY PROJECT MANAGER T. BRADLEY



- LEGEND**
- HB — HIGHWAY BOUNDARY
  - FEE — FEE ACQUISITION
  - TE — TEMPORARY EASEMENT
  - FW — FEDERAL WETLAND
  - O.H.W. — ORDINARY HIGH WATER
  - GR — GUIDE RAIL
  - ST — SEWER, STORM
  - D — DRAINAGE DITCH



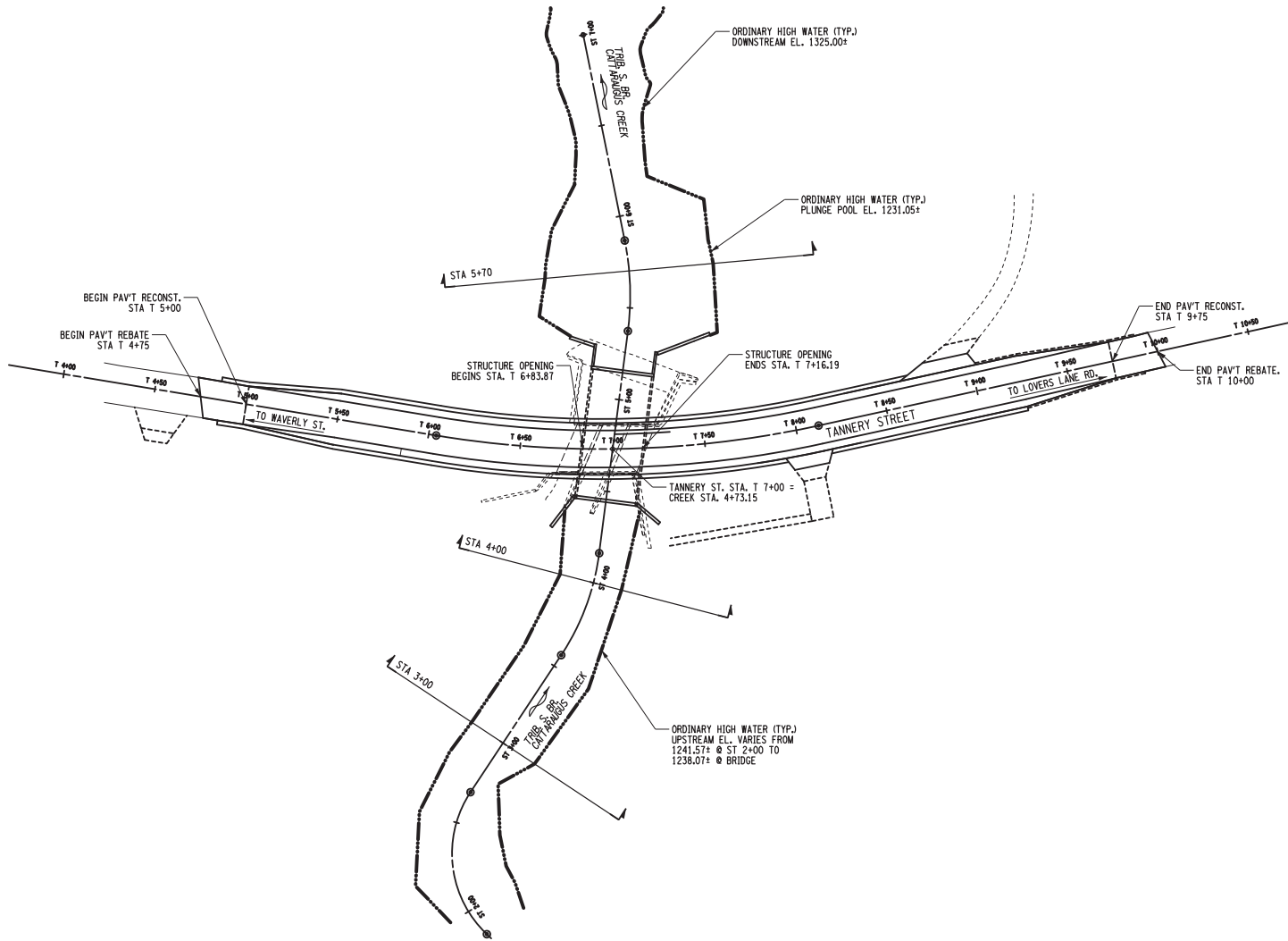
THIS DRAWING IS PROVIDED FOR INFORMATIONAL PURPOSES ONLY. THE DRAWING CONTENTS ARE NOT AN APPROVED FINAL CONSTRUCTION CONTRACT DOCUMENT	TANNERY STREET OVER TRIB. S. BR. CATTARAUGUS CREEK	PIN 5757.33	BRIDGES 3322810	CULVERTS	ALL DIM	Cattaraugus County DPW LRB-2019-00398 Sheet 2 of 21
	VILLAGE OF CATTARAUGUS AND TOWN OF NEW ALBION					
	COUNTY: CATTARAUGUS	REGION: 5				



NOTE:  
 FOR LEGEND SEE DWG. NO. PERM-1



THIS DRAWING IS PROVIDED FOR INFORMATIONAL PURPOSES ONLY. THE DRAWING CONTENTS ARE NOT AN APPROVED FINAL CONSTRUCTION CONTRACT DOCUMENT	TANNERY STREET OVER TRIB. S. BR. CATTARAUGUS CREEK	PIN 5757.33	BRIDGES 3322810	CULVERTS	Cattaraugus County DPW LRB-2019-00398 Sheet 3 of 21
	VILLAGE OF CATTARAUGUS AND TOWN OF NEW ALBION				
	COUNTY: CATTARAUGUS REGION: 5				

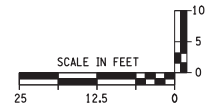
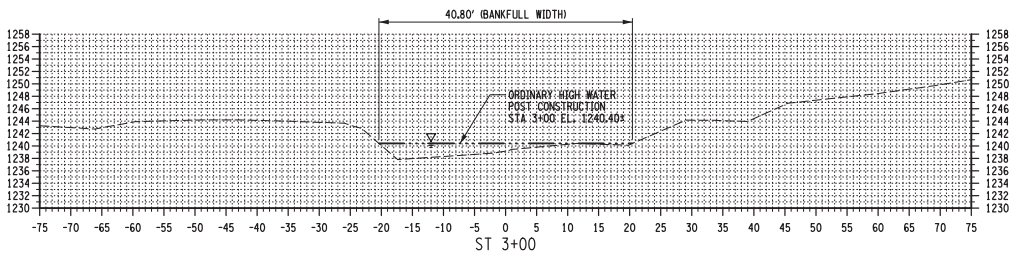
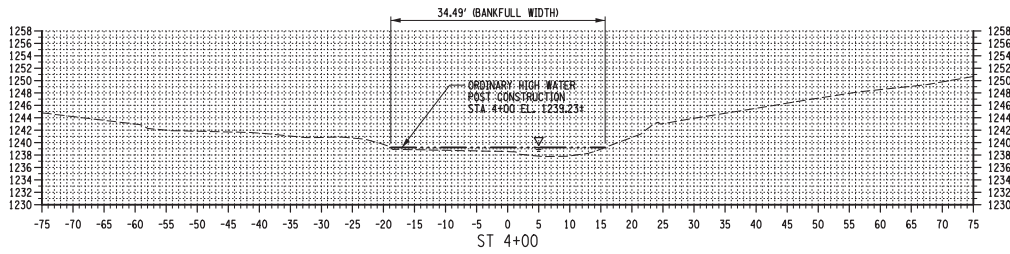
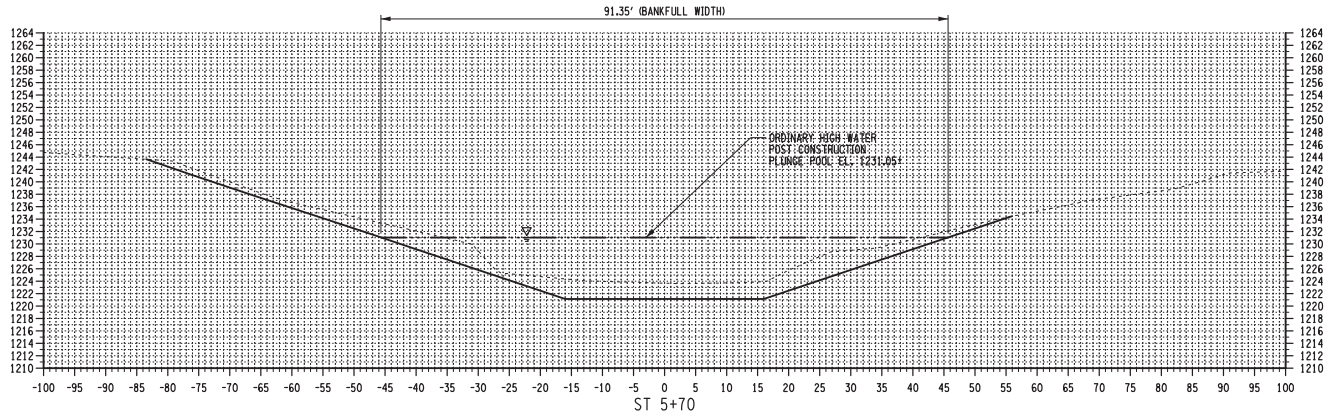


NOTE:  
 SEE DRAWING NO. PERM-4 FOR CROSS  
 SECTIONS AND BANKFILL WIDTHS.



THIS DRAWING IS PROVIDED FOR INFORMATIONAL PURPOSES ONLY. THE DRAWING CONTENTS ARE NOT AN APPROVED FINAL CONSTRUCTION CONTRACT DOCUMENT	TANNERY STREET OVER TRIB. S. BR. CATTARAUGUS CREEK	PIN 5757.33	BRIDGES 3322810	CULVERTS	Cattaraugus County DPW LRB-2019-00398 Sheet 4 of 21
	VILLAGE OF CATTARAUGUS AND TOWN OF NEW ALBION				
	COUNTY: CATTARAUGUS	REGION: 5			

DEPARTMENT OF PUBLIC WORKS

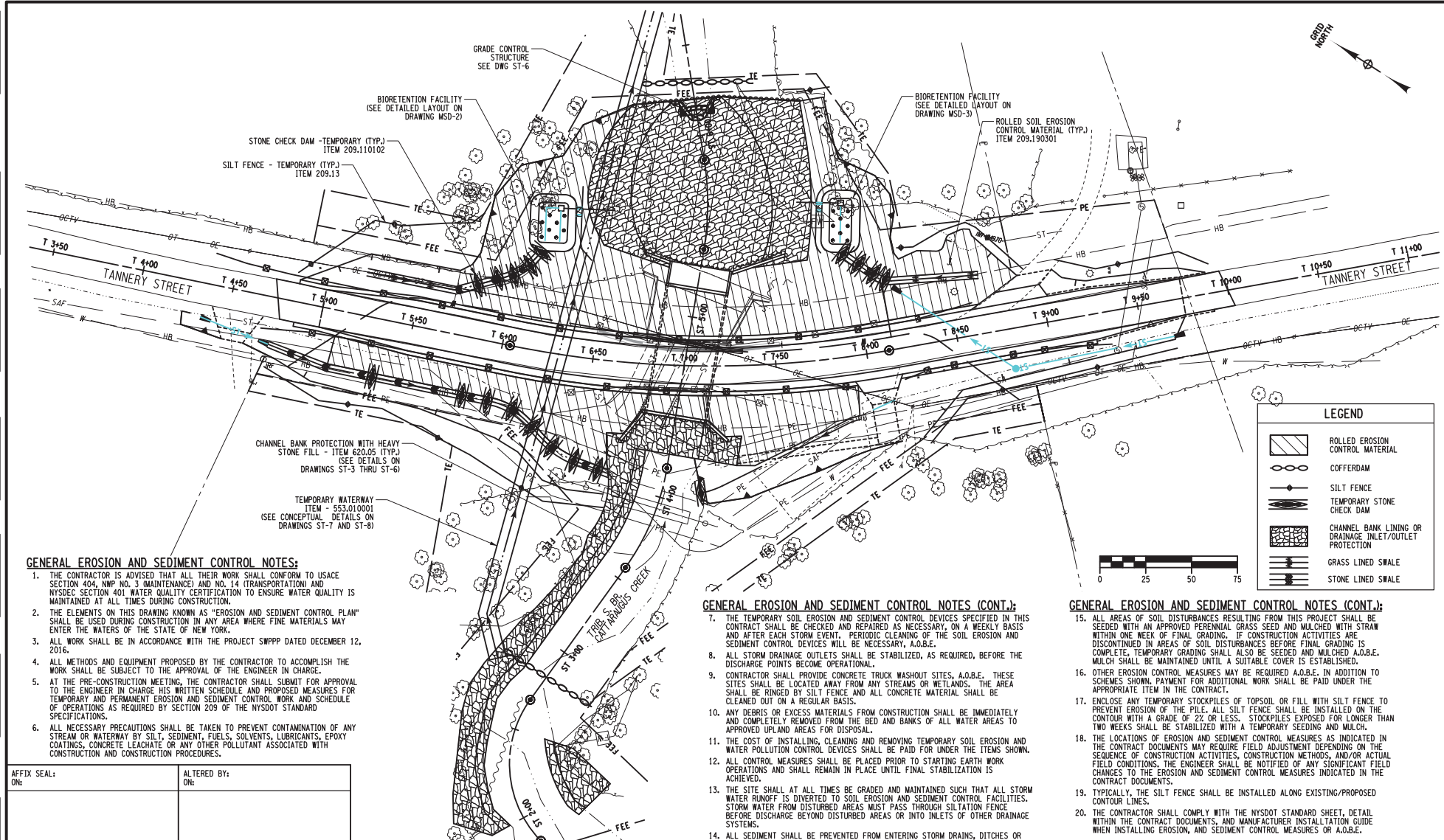


THIS DRAWING IS PROVIDED FOR INFORMATIONAL PURPOSES ONLY. THE DRAWING CONTENTS ARE NOT AN APPROVED FINAL CONSTRUCTION CONTRACT DOCUMENT	TANNERY STREET OVER TRIB. S. BR. CATTARAUGUS CREEK	PIN 5757.33	BRIDGES 3322810	CULVERTS	ALL DIMENSIONS IN ft UNLESS OTHERWISE NOTED
	VILLAGE OF CATTARAUGUS AND TOWN OF NEW ALBION				
	COUNTY: CATTARAUGUS      REGION: 5				
					Cattaraugus County DPW LRB-2019-00398 Sheet 5 of 21



FILE NAME = L:\19250012\environmental\Permits\5\Permit - Drawings\PERM-5.dgn  
 DATE/TIME = 2/10/2019 2:05:51 PM  
 USER = kdobris

DESIGN SUPERVISOR T. BRADLEY  
 JOB MANAGER S. MILLER/T. BRADLEY  
 DESIGN D. CLARK  
 S. MILLER / CHECK T. BRADLEY  
 DRAFTING D. CLARK  
 S. MILLER / CHECK T. BRADLEY  
 PROJECT MANAGER T. BRADLEY



LEGEND	
	ROLLED EROSION CONTROL MATERIAL
	COFFERDAM
	SILT FENCE
	TEMPORARY STONE CHECK DAM
	CHANNEL BANK LINING OR PROTECTION
	GRASS LINED SWALE
	STONE LINED SWALE

**GENERAL EROSION AND SEDIMENT CONTROL NOTES:**

1. THE CONTRACTOR IS ADVISED THAT ALL THEIR WORK SHALL CONFORM TO USACE SECTION 404, NHP NO. 3 (MAINTENANCE) AND NO. 14 (TRANSPORTATION) AND NYSDEC SECTION 401 WATER QUALITY CERTIFICATION TO ENSURE WATER QUALITY IS MAINTAINED AT ALL TIMES DURING CONSTRUCTION.
2. THE ELEMENTS ON THIS DRAWING KNOWN AS "EROSION AND SEDIMENT CONTROL PLAN" SHALL BE USED DURING CONSTRUCTION IN ANY AREA WHERE FINE MATERIALS MAY ENTER THE WATERS OF THE STATE OF NEW YORK.
3. ALL WORK SHALL BE IN ACCORDANCE WITH THE PROJECT SWPPP DATED DECEMBER 12, 2016.
4. ALL METHODS AND EQUIPMENT PROPOSED BY THE CONTRACTOR TO ACCOMPLISH THE WORK SHALL BE SUBJECT TO THE APPROVAL OF THE ENGINEER IN CHARGE.
5. AT THE PRE-CONSTRUCTION MEETING, THE CONTRACTOR SHALL SUBMIT FOR APPROVAL TO THE ENGINEER IN CHARGE HIS WRITTEN SCHEDULE AND PROPOSED MEASURES FOR TEMPORARY AND PERMANENT EROSION AND SEDIMENT CONTROL WORK AND SCHEDULE OF OPERATIONS AS REQUIRED BY SECTION 209 OF THE NYSDOT STANDARD SPECIFICATIONS.
6. ALL NECESSARY PRECAUTIONS SHALL BE TAKEN TO PREVENT CONTAMINATION OF ANY STREAM OR WATERWAY BY SILT, SEDIMENT, FUELS, SOLVENTS, LUBRICANTS, EPOXY COATINGS, CONCRETE LEACHATE OR ANY OTHER POLLUTANT ASSOCIATED WITH CONSTRUCTION AND CONSTRUCTION PROCEDURES.

**GENERAL EROSION AND SEDIMENT CONTROL NOTES (CONT.):**

7. THE TEMPORARY SOIL EROSION AND SEDIMENT CONTROL DEVICES SPECIFIED IN THIS CONTRACT SHALL BE CHECKED AND REPAIRED AS NECESSARY, ON A WEEKLY BASIS AND AFTER EACH STORM EVENT. PERIODIC CLEANING OF THE SOIL EROSION AND SEDIMENT CONTROL DEVICES WILL BE NECESSARY, A.O.B.E.
8. ALL STORM DRAINAGE OUTLETS SHALL BE STABILIZED, AS REQUIRED, BEFORE THE DISCHARGE POINTS BECOME OPERATIONAL.
9. CONTRACTOR SHALL PROVIDE CONCRETE TRUCK WASHOUT SITES, A.O.B.E. THESE SITES SHALL BE LOCATED AWAY FROM ANY STREAMS OR WETLANDS. THE AREA SHALL BE RINGED BY SILT FENCE AND ALL CONCRETE MATERIAL SHALL BE CLEANED OUT ON A REGULAR BASIS.
10. ANY DEBRIS OR EXCESS MATERIALS FROM CONSTRUCTION SHALL BE IMMEDIATELY AND COMPLETELY REMOVED FROM THE BED AND BANKS OF ALL WATER AREAS TO APPROVED UPLAND AREAS FOR DISPOSAL.
11. THE COST OF INSTALLING, CLEANING AND REMOVING TEMPORARY SOIL EROSION AND WATER POLLUTION CONTROL DEVICES SHALL BE PAID FOR UNDER THE ITEMS SHOWN.
12. ALL CONTROL MEASURES SHALL BE PLACED PRIOR TO STARTING EARTH WORK OPERATIONS AND SHALL REMAIN IN PLACE UNTIL FINAL STABILIZATION IS ACHIEVED.
13. THE SITE SHALL AT ALL TIMES BE GRADED AND MAINTAINED SUCH THAT ALL STORM WATER RUNOFF IS DIVERTED TO SOIL EROSION AND SEDIMENT CONTROL FACILITIES. STORM WATER FROM DISTURBED AREAS MUST PASS THROUGH SILTATION FENCE BEFORE DISCHARGE BEYOND DISTURBED AREAS OR INTO INLETS OF OTHER DRAINAGE SYSTEMS.
14. ALL SEDIMENT SHALL BE PREVENTED FROM ENTERING STORM DRAINS, DITCHES OR WATER COURSES.

**GENERAL EROSION AND SEDIMENT CONTROL NOTES (CONT.):**

15. ALL AREAS OF SOIL DISTURBANCES RESULTING FROM THIS PROJECT SHALL BE SEEDED WITH AN APPROVED PERENNIAL GRASS SEED AND MULCHED WITH STRAW WITHIN ONE WEEK OF FINAL GRADING. IF CONSTRUCTION ACTIVITIES ARE DISCONTINUED IN AREAS OF SOIL DISTURBANCES BEFORE FINAL GRADING IS COMPLETE, TEMPORARY GRADING SHALL ALSO BE SEEDED AND MULCHED A.O.B.E. MULCH SHALL BE MAINTAINED UNTIL A SUITABLE COVER IS ESTABLISHED.
16. OTHER EROSION CONTROL MEASURES MAY BE REQUIRED A.O.B.E. IN ADDITION TO SCHEMES SHOWN. PAYMENT FOR ADDITIONAL WORK SHALL BE PAID UNDER THE APPROPRIATE ITEM IN THE CONTRACT.
17. ENCLOSE ANY TEMPORARY STOCKPILES OF TOPSOIL OR FILL WITH SILT FENCE TO PREVENT EROSION OF THE PILE. ALL SILT FENCE SHALL BE INSTALLED ON THE CONTOUR WITH A GRADE OF 2% OR LESS. STOCKPILES EXPOSED FOR LONGER THAN TWO WEEKS SHALL BE STABILIZED WITH A TEMPORARY SEEDING AND MULCH.
18. THE LOCATIONS OF EROSION AND SEDIMENT CONTROL MEASURES AS INDICATED IN THE CONTRACT DOCUMENTS MAY REQUIRE FIELD ADJUSTMENT DEPENDING ON THE SEQUENCE OF CONSTRUCTION ACTIVITIES, CONSTRUCTION METHODS, AND/OR ACTUAL FIELD CONDITIONS. THE ENGINEER SHALL BE NOTIFIED OF ANY SIGNIFICANT FIELD CHANGES TO THE EROSION AND SEDIMENT CONTROL MEASURES INDICATED IN THE CONTRACT DOCUMENTS.
19. TYPICALLY, THE SILT FENCE SHALL BE INSTALLED ALONG EXISTING/PROPOSED CONTOUR LINES.
20. THE CONTRACTOR SHALL COMPLY WITH THE NYSDOT STANDARD SHEET, DETAIL WITHIN THE CONTRACT DOCUMENTS AND MANUFACTURER INSTALLATION GUIDE WHEN INSTALLING EROSION, AND SEDIMENT CONTROL MEASURES OR A.O.B.E.

AFFIX SEAL: ON  
 ALTERED BY: ON

AS-BUILT REVISIONS DESCRIPTION OF ALTERATIONS:	TANNERY STREET OVER TRIB. S. BR. CATTARAUGUS CREEK	PIN 5757.33	BRIDGES 3322810	CULVERTS	ALL DIMENSIONS IN FT UNLESS OTHERWISE NOTED
	VILLAGE OF CATTARAUGUS AND TOWN OF NEW ALBION				EROSION AND SEDIMENT CONTROL PLAN
	COUNTY: CATTARAUGUS	REGION: 5			Cattaraugus County DPW LRB-2019-00398

IT IS A VIOLATION OF LAW FOR ANY PERSON, UNLESS THEY ARE ACTING UNDER THE DIRECTION OF A LICENSED PROFESSIONAL ENGINEER, ARCHITECT, LANDSCAPE ARCHITECT, OR LAND SURVEYOR, TO ALTER AN ITEM IN ANY WAY, IF AN ITEM BEARING THE STAMP OF A LICENSED PROFESSIONAL IS ALTERED, THE ALTERING ENGINEER, ARCHITECT, LANDSCAPE ARCHITECT, OR LAND SURVEYOR SHALL STAMP THE DOCUMENT AND INCLUDE THE NOTATION "ALTERED BY" FOLLOWED BY THEIR SIGNATURE, THE DATE OF SUCH ALTERATION, AND A SPECIFIC DESCRIPTION OF THE ALTERATION.

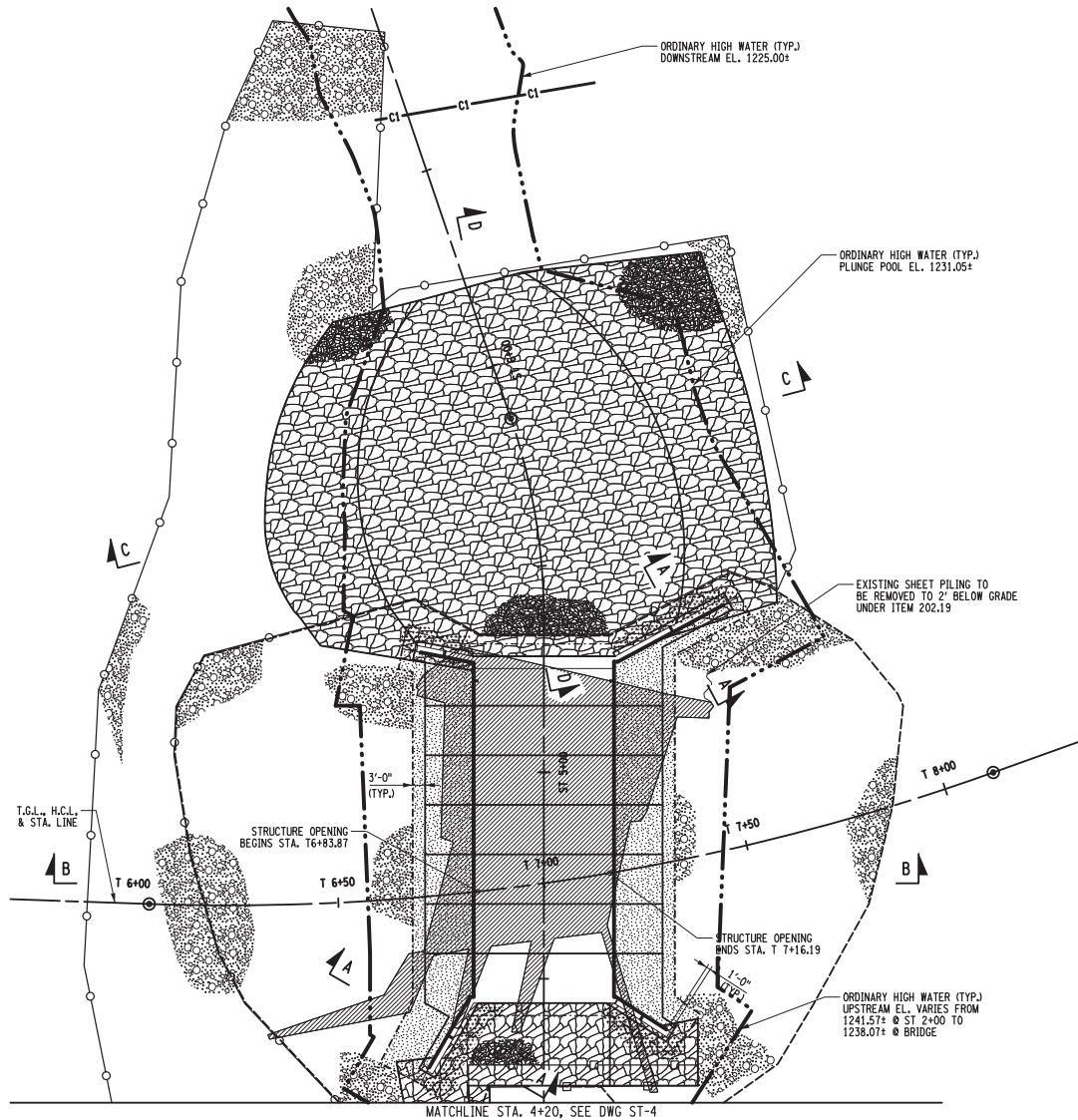
CATTARAUGUS COUNTY DEPARTMENT OF PUBLIC WORKS	Sheet 6 of 21
--	---------------

FILE NAME = L:\192500172\environmental\Permits\6.dgn  
 DATE/TIME = 2/10/2019 2:05:53 PM  
 USER = kdobris

DESIGN SUPERVISOR T. BRADLEY JOB MANAGER S. MILLER/ T. BRADLEY DESIGN D. CLARK S. MILLER/ T. BRADLEY CHECK T. BRADLEY DRAFTING D. CLARK S. MILLER/ T. BRADLEY CHECK T. BRADLEY PROJECT MANAGER T. BRADLEY



- LEGEND**
- SELECT STRUCTURE FILL (ITEM 203.21), COMPACTED TO 95% OF STANDARD PROCTOR MAXIMUM DENSITY
  - HIGHWAY EMBANKMENT MATERIAL, ITEM 203.03
  - BACKFILL WITH SUITABLE EXCAVATED MATERIAL AS PROVIDED FOR UNDER ITEM 206.01, STRUCTURE EXCAVATION.
  - STONE FILLING (HEAVY), ITEM 620.05
  - BEDDING MATERIAL, ITEM 620.08
  - REMOVAL OF SUBSTRUCTURES, ITEM 202.19
  - CRUSHED MATERIAL MEETING THE REQUIREMENTS OF MATERIAL DESIGNATION 703.0201, 703-0202, OR 703-0204 WITH A PRIMARY SIZE DESIGNATION 2. ITEM 623.12 CRUSHED STONE (IN-PLACE MEASURE)
  - AREA ENCLOSED WITHIN THESE LINES DESIGNATES PAYMENT LINES FOR STRUCTURE EXCAVATION, ITEM 206.01
  - AREA ENCLOSED WITHIN THESE LINES DESIGNATES PAYMENT LINES FOR UNCLASSIFIED EXCAVATION AND DISPOSAL, ITEM 203.02
  - AREA ENCLOSED WITHIN THESE LINES DESIGNATES PAYMENT LINES FOR TRENCH AND CULVERT EXCAVATION, ITEM 206.0201
  - AREA ENCLOSED WITHIN THESE LINES DESIGNATES PAYMENT LINES FOR STRUCTURE EXCAVATION, ITEM 623.12 CRUSHED STONE (IN-PLACE MEASURE)
  - PREFABRICATED COMPOSITE STRUCTURAL DRAIN, ITEM 207.26
  - DESIGNATES COFFERDAM (TYPE 1), ITEM 553.010001 INLET SIDE, ITEM 553.010002 OUTLET SIDE



- NOTES:**
- EXISTING STRUCTURE TO BE COMPLETELY REMOVED.
  - THE CONTRACTOR SHALL MAINTAIN CREEK FLOW THROUGHOUT THE DURATION OF THE PROJECT. MEANS AND METHODS OF MAINTAINING FLOW SHALL BE THE RESPONSIBILITY OF THE CONTRACTOR. COST SHALL BE INCLUDED UNDER ITEMS 553.010001 AND 553.010002 COFFERDAMS (TYPE 1).



AFFIX SEAL: ON:	ALTERED BY: ON:

AS-BUILT REVISIONS DESCRIPTION OF ALTERATIONS:	TANNERY STREET OVER TRIB. S. BR. CATTARAUGUS CREEK	PIN 5757.33	BRIDGES 3322810	CULVERTS	ALL DIMENSIONS IN FT UNLESS OTHERWISE NOTED
	VILLAGE OF CATTARAUGUS AND TOWN OF NEW ALBION				DEMOLITION, EXCAVATION AND EMBANKMENT PL
COUNTY: CATTARAUGUS	REGION: 5	Cattaraugus County DPW LRB-2019-00398 Sheet 7 of 21			
IT IS A VIOLATION OF LAW FOR ANY PERSON, UNLESS THEY ARE ACTING UNDER THE DIRECTION OF A LICENSED PROFESSIONAL ENGINEER, ARCHITECT, LANDSCAPE ARCHITECT, OR LAND SURVEYOR, TO ALTER AN ITEM IN ANY WAY. IF AN ITEM BEARING THE STAMP OF A LICENSED PROFESSIONAL IS ALTERED, THE ALTERING ENGINEER, ARCHITECT, LANDSCAPE ARCHITECT, OR LAND SURVEYOR SHALL STAMP THE DOCUMENT AND INCLUDE THE NOTATION "ALTERED BY:" FOLLOWED BY THEIR SIGNATURE, THE DATE OF SUCH ALTERATION, AND A SPECIFIC DESCRIPTION OF THE ALTERATION.					CATTARAUGUS COUNTY DEPARTMENT OF PUBLIC WORKS

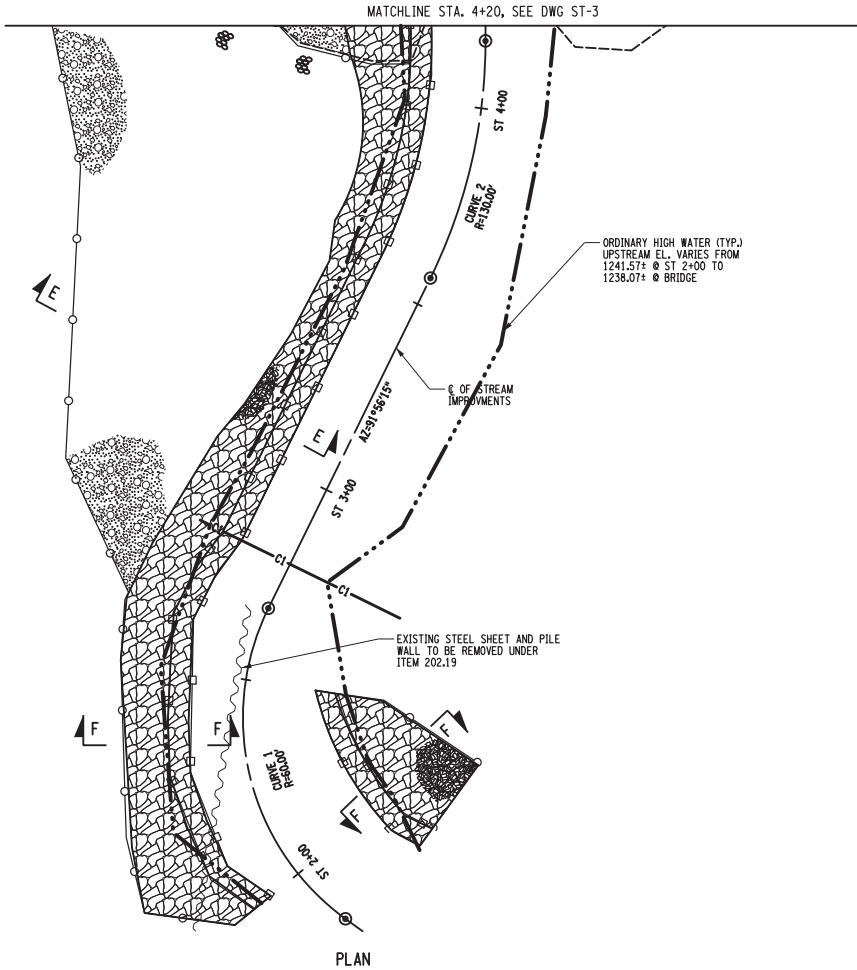
FILE NAME = L:\192500172\environmental\Permits\Permit Drawings\PERM-7.dgn  
 DATE/TIME = 2/10/2019 2:05:54 PM  
 USER = kdobris

DESIGN SUPERVISOR T. BRADLEY PROJECT MANAGER T. BRADLEY  
 JOB MANAGER S. MILLER/T. BRADLEY DESIGN D. CLARK  
 S. MILLER/T. BRADLEY CHECK T. BRADLEY  
 S. MILLER/T. BRADLEY CHECK T. BRADLEY  
 DRAFTING D. CLARK



**LEGEND**

- SELECT STRUCTURE FILL (ITEM 203.21), COMPACTED TO 95% OF STANDARD PROCTOR MAXIMUM DENSITY
- HIGHWAY EMBANKMENT MATERIAL, ITEM 203.03
- BACKFILL WITH SUITABLE EXCAVATED MATERIAL AS PROVIDED FOR UNDER ITEM 206.01, STRUCTURE EXCAVATION.
- STONE FILLING (HEAVY), ITEM 620.05
- BEDDING MATERIAL, ITEM 620.08
- REMOVAL OF SUBSTRUCTURES, ITEM 202.19
- CRUSHED MATERIAL MEETING THE REQUIREMENTS OF MATERIAL DESIGNATION 703.0201, 703.0202, OR 703.0204 WITH A PRIMARY SIZE DESIGNATION 2, ITEM 623.12 CRUSHED STONE (IN-PLACE MEASURE)
- AREA ENCLOSED WITHIN THESE LINES DESIGNATES PAYMENT LINES FOR STRUCTURE EXCAVATION, ITEM 206.01
- AREA ENCLOSED WITHIN THESE LINES DESIGNATES PAYMENT LINES FOR UNCLASSIFIED EXCAVATION AND DISPOSAL, ITEM 203.02
- AREA ENCLOSED WITHIN THESE LINES DESIGNATES PAYMENT LINES FOR TRENCH AND CULVERT EXCAVATION, ITEM 206.0201
- AREA ENCLOSED WITHIN THESE LINES DESIGNATES PAYMENT LINES FOR STRUCTURE EXCAVATION, ITEM 623.12 CRUSHED STONE (IN-PLACE MEASURE)
- PREFABRICATED COMPOSITE STRUCTURAL DRAIN, ITEM 207.26
- DESIGNATES COFFERDAM (TYPE 1), ITEM 553.010001 INLET SIDE, ITEM 553.010002 OUTLET SIDE



ORDINARY HIGH WATER (TYP.)  
 UPSTREAM EL. VARIES FROM  
 1241.57+ @ ST 2+00 TO  
 1238.07+ @ BRIDGE

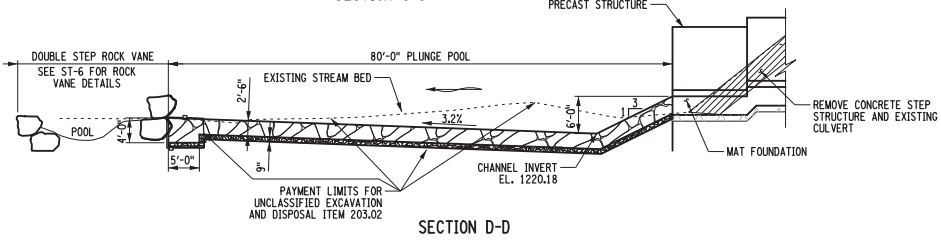
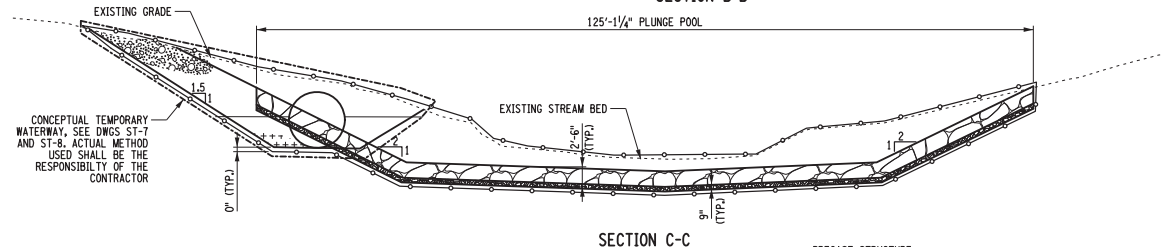
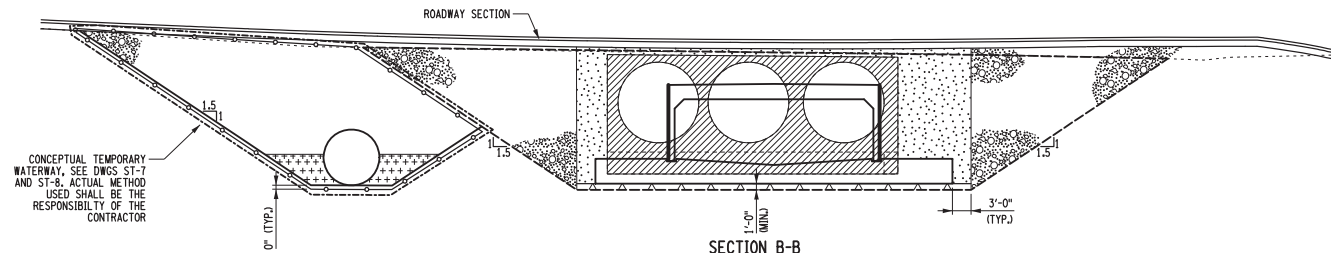
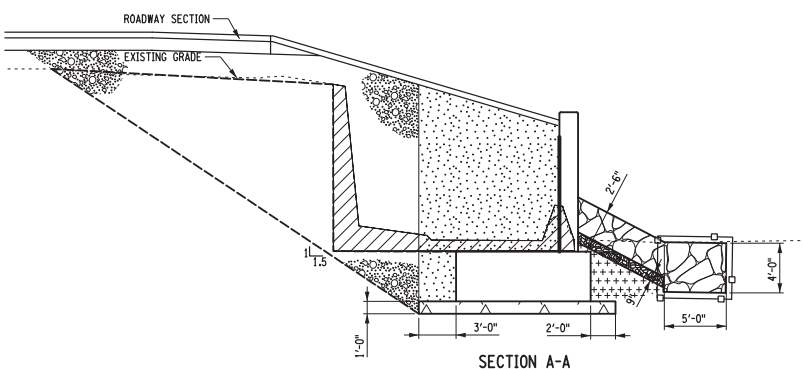
AFFIX SEAL: ON:	ALTERED BY: ON:

AS-BUILT REVISIONS DESCRIPTION OF ALTERATIONS:	TANNERY STREET OVER TRIB. S. BR. CATTARAUGUS CREEK	PIN 5757.33	BRIDGES 3322810	CULVERTS
	VILLAGE OF CATTARAUGUS AND TOWN OF NEW ALBION			
	COUNTY: CATTARAUGUS	REGION: 5		
IT IS A VIOLATION OF LAW FOR ANY PERSON, UNLESS THEY ARE ACTING UNDER THE DIRECTION OF A LICENSED PROFESSIONAL ENGINEER, ARCHITECT, LANDSCAPE ARCHITECT, OR LAND SURVEYOR, TO ALTER AN ITEM IN ANY WAY. IF AN ITEM BEARING THE STAMP OF A LICENSED PROFESSIONAL IS ALTERED, THE ALTERING ENGINEER, ARCHITECT, LANDSCAPE ARCHITECT, OR LAND SURVEYOR SHALL STAMP THE DOCUMENT AND INCLUDE THE NOTATION "ALTERED BY" FOLLOWED BY THEIR SIGNATURE, THE DATE OF SUCH ALTERATION, AND A SPECIFIC DESCRIPTION OF THE ALTERATION.				

**NOTES:**

1. EXISTING STRUCTURE TO BE COMPLETELY REMOVED.
2. THE CONTRACTOR SHALL MAINTAIN CREEK FLOW THROUGHOUT THE DURATION OF THE PROJECT. MEANS AND METHODS OF MAINTAINING FLOW SHALL BE THE RESPONSIBILITY OF THE CONTRACTOR. COST SHALL BE INCLUDED UNDER ITEMS 553.010001 AND 553.010002, COFFERDAMS (TYPE 1).

ALL DIMENSIONS IN FT UNLESS OTHERWISE NOTED	
DEMOLITION, EXC EMBANKMEN	Cattaraugus County DPW LRB-2019-00398 Sheet 8 of 21
CATTARAUGUS COUN DEPARTMENT OF PUBLIC	



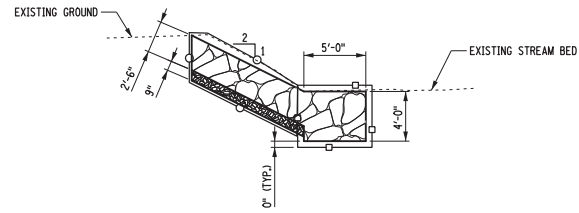
- NOTES:**
- EXISTING STRUCTURE TO BE COMPLETELY REMOVED.
- LEGEND**
- [Pattern] SELECT STRUCTURE FILL (ITEM 203.21), COMPACTED TO 95% OF STANDARD PROCTOR MAXIMUM DENSITY
  - [Pattern] HIGHWAY EMBANKMENT MATERIAL, ITEM 203.03
  - [Pattern] BACKFILL WITH SUITABLE EXCAVATED MATERIAL AS PROVIDED FOR UNDER ITEM 206.01, STRUCTURE EXCAVATION.
  - [Pattern] STONE FILLING (HEAVY), ITEM 620.05
  - [Pattern] BEDDING MATERIAL, ITEM 620.08
  - [Pattern] REMOVAL OF SUBSTRUCTURES, ITEM 202.19
  - [Pattern] CRUSHED MATERIAL MEETING THE REQUIREMENTS OF MATERIAL DESIGNATION 703.0201, 703-0202, OR 703-0204 WITH A PRIMARY SIZE DESIGNATION 2. ITEM 623.12 CRUSHED STONE (IN-PLACE MEASURE)
  - [---] AREA ENCLOSED WITHIN THESE LINES DESIGNATES PAYMENT LINES FOR STRUCTURE EXCAVATION, ITEM 206.01
  - [---] AREA ENCLOSED WITHIN THESE LINES DESIGNATES PAYMENT LINES FOR UNCLASSIFIED EXCAVATION AND DISPOSAL, ITEM 203.02
  - [---] AREA ENCLOSED WITHIN THESE LINES DESIGNATES PAYMENT LINES FOR TRENCH AND CULVERT EXCAVATION, ITEM 206.0201
  - [---] PREFABRICATED COMPOSITE STRUCTURAL DRAIN, ITEM 207.26

AFFIX SEAL: ON:	ALTERED BY: ON:

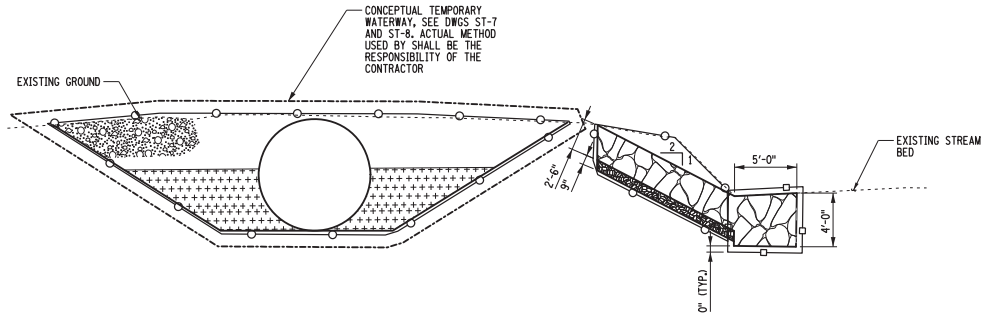
AS-BUILT REVISIONS DESCRIPTION OF ALTERATIONS:	TANNERY STREET OVER TRIB. S. BR. CATTARAUGUS CREEK	PIN 5757.33	BRIDGES 3322810	CULVERTS	ALL DIMENSIONS IN FT UNLESS OTHERWISE NOTED
	VILLAGE OF CATTARAUGUS AND TOWN OF NEW ALBION				
	COUNTY: CATTARAUGUS	REGION: 5			

DEMOLITION, EXCAVATION, EMBANKMENT SECTION	Cattaraugus County DPW LRB-2019-00398 Sheet 9 of 21
CATTARAUGUS COUNTY DEPARTMENT OF PUBLIC WORKS	

IT IS A VIOLATION OF LAW FOR ANY PERSON, UNLESS THEY ARE ACTING UNDER THE DIRECTION OF A LICENSED PROFESSIONAL ENGINEER, ARCHITECT, LANDSCAPE ARCHITECT, OR LAND SURVEYOR, TO ALTER AN ITEM IN ANY WAY. IF AN ITEM BEARING THE STAMP OF A LICENSED PROFESSIONAL IS ALTERED, THE ALTERING ENGINEER, ARCHITECT, LANDSCAPE ARCHITECT, OR LAND SURVEYOR SHALL STAMP THE DOCUMENT AND INCLUDE THE NOTATION "ALTERED BY" FOLLOWED BY THEIR SIGNATURE, THE DATE OF SUCH ALTERATION, AND A SPECIFIC DESCRIPTION OF THE ALTERATION.



SECTION F-F

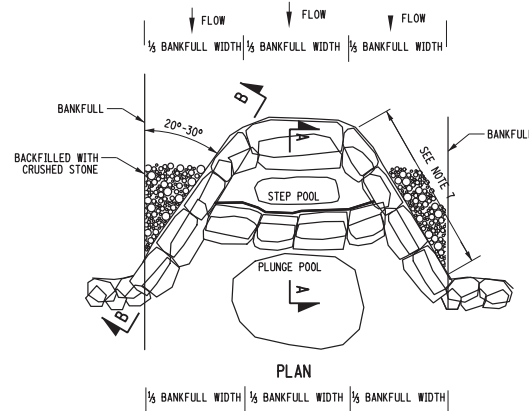


SECTION E-E

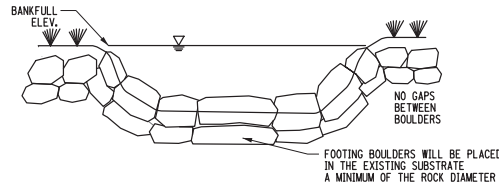
- NOTES:**  
 1. EXISTING STRUCTURE TO BE COMPLETELY REMOVED.

**LEGEND**

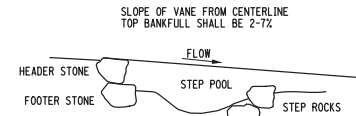
- SELECT STRUCTURE FILL (ITEM 203.21), COMPACTED TO 95% OF STANDARD PROCTOR MAXIMUM DENSITY
- HIGHWAY EMBANKMENT MATERIAL, ITEM 203.03
- BACKFILL WITH SUITABLE EXCAVATED MATERIAL AS PROVIDED FOR UNDER ITEM 206.01, STRUCTURE EXCAVATION.
- STONE FILLING (HEAVY), ITEM 620.05
- BEDDING MATERIAL, ITEM 620.08
- REMOVAL OF SUBSTRUCTURES, ITEM 202.19
- CRUSHED MATERIAL MEETING THE REQUIREMENTS OF MATERIAL DESIGNATION 703.0201, 703-0202, OR 703-0204 WITH A PRIMARY SIZE DESIGNATION 2, ITEM 623.12 CRUSHED STONE (IN-PLACE MEASURE)
- AREA ENCLOSED WITHIN THESE LINES DESIGNATES PAYMENT LINES FOR STRUCTURE EXCAVATION, ITEM 206.01
- AREA ENCLOSED WITHIN THESE LINES DESIGNATES PAYMENT LINES FOR UNCLASSIFIED EXCAVATION AND DISPOSAL, ITEM 203.02
- AREA ENCLOSED WITHIN THESE LINES DESIGNATES PAYMENT LINES FOR TRENCH AND CULVERT EXCAVATION, ITEM 206.0201
- PREFABRICATED COMPOSITE STRUCTURAL DRAIN, ITEM 207.26



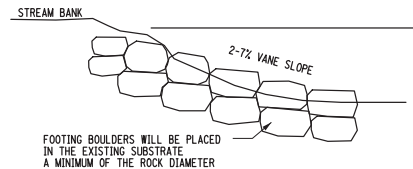
PLAN



CROSS-SECTION



SECTION A-A



SECTION B-B

1. ALL STONES ARE TO BE STRUCTURE STONE.
2. GAPS BETWEEN BOULDERS SHALL BE MINIMIZED BY FITTING BOULDERS TOGETHER, PLUGGING WITH CRUSHED STONE OR CHINKING STONE APPROVED BY DESIGN ENGINEER AND LINING WITH FILTER FABRIC.
3. DIMENSIONS AND SLOPES MAY BE ADJUSTED TO IT BY THE DESIGN ENGINEER.
4. CONTRACTOR WILL BE REQUIRED TO FIT BOULDERS TIGHTLY.
5. FOOTER BOULDERS AND VANE BOULDERS SHALL BE NATIVE STONE OR SHOT ROCK, CUBICAL OR RECTANGULAR IN NATURE.
6. SLOPE OF VANE FROM CENTERLINE TO THE TOP OF THE VANE ARM SHALL BE 2-7%.
7. ELEVATION CHANGE SHALL BE SPLIT EVENLY OVER TWO DROPS.
8. THERE SHALL BE NO DROP GREATER THAN 6 INCHES.
9. THE ELEVATION OF EACH GRADE CONTROL STRUCTURE SHOULD BE EQUAL TO OR GREATER THAN THE ELEVATION OF THE TOP OF THE FOOTER ROCKS DIRECTLY UPSTREAM.

AFFIX SEAL: ON:	ALTERED BY: ON:

AS-BUILT REVISIONS DESCRIPTION OF ALTERATIONS:	TANNERY STREET OVER TRIB. S. BR. CATTARAUGUS CREEK	PIN 5757.33	BRIDGES 3322810	CULVERTS	ALL DIMENSIONS IN ft UNLESS OTHERWISE NOTED
	VILLAGE OF CATTARAUGUS AND TOWN OF NEW ALBION				
COUNTY: CATTARAUGUS		REGION: 5	DEMOLITION, EX EMBANKMENT		
IT IS A VIOLATION OF LAW FOR ANY PERSON, UNLESS THEY ARE ACTING UNDER THE DIRECTION OF A LICENSED PROFESSIONAL ENGINEER, ARCHITECT, LANDSCAPE ARCHITECT, OR LAND SURVEYOR, TO ALTER AN ITEM IN ANY WAY. IF AN ITEM BEARING THE STAMP OF A LICENSED PROFESSIONAL IS ALTERED, THE ALTERING ENGINEER, ARCHITECT, LANDSCAPE ARCHITECT, OR LAND SURVEYOR SHALL STAMP THE DOCUMENT AND INCLUDE THE NOTATION "ALTERED BY:" FOLLOWED BY THEIR SIGNATURE, THE DATE OF SUCH ALTERATION, AND A SPECIFIC DESCRIPTION OF THE ALTERATION.					
CATTARAUGUS COUNTY DEPARTMENT OF PUBLIC WORKS					Cattaraugus County DPW LRB-2019-00398 Sheet 10 of 21

FILE NAME = L:\91325001\28\Transportation\design\dwg\catt\plan\_Sep1920 - CNP-1.dgn  
 DATE/TIME = 2/6/2019 11:50:35 AM  
 USER = kdobarris

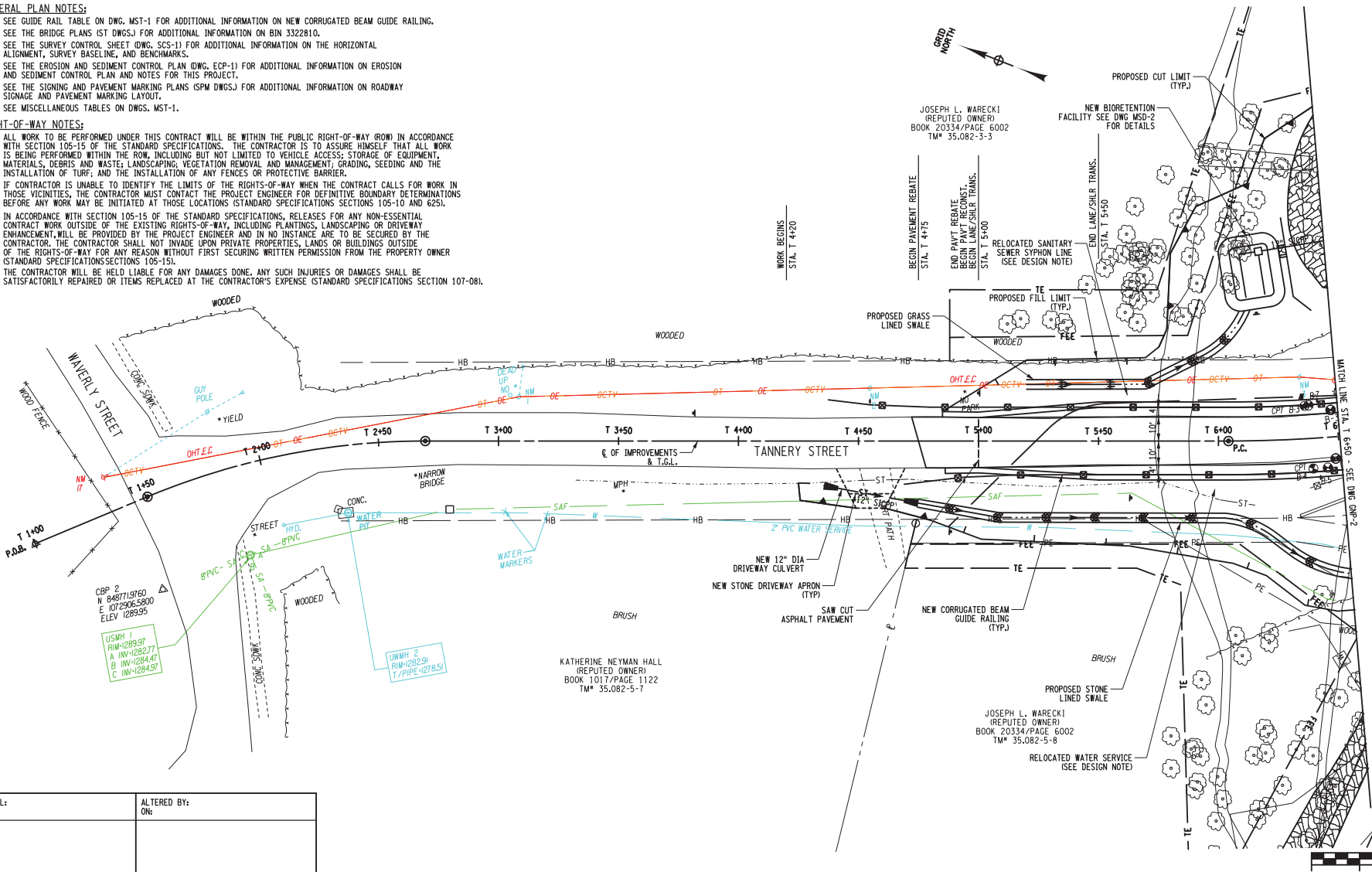
DESIGN SUPERVISOR T. BRADLEY  
 JOB MANAGER S. MILLER/T. BRADLEY  
 DESIGN D. CLARK  
 S. MILLER / T. BRADLEY  
 CHECK T. BRADLEY  
 DRAFTING D. CLARK  
 S. MILLER / T. BRADLEY  
 CHECK T. BRADLEY  
 PROJECT MANAGER T. BRADLEY

**GENERAL PLAN NOTES:**

- SEE GUIDE RAIL TABLE ON DWG. MST-1 FOR ADDITIONAL INFORMATION ON NEW CORRUGATED BEAM GUIDE RAILING.
- SEE THE BRIDGE PLANS (ST DWGS.) FOR ADDITIONAL INFORMATION ON BIN 3322810.
- SEE THE SURVEY CONTROL SHEET (DWG. SCS-1) FOR ADDITIONAL INFORMATION ON THE HORIZONTAL ALIGNMENT, SURVEY BASELINE, AND BENCHMARKS.
- SEE THE EROSION AND SEDIMENT CONTROL PLAN (DWG. ECP-1) FOR ADDITIONAL INFORMATION ON EROSION AND SEDIMENT CONTROL PLAN AND NOTES FOR THIS PROJECT.
- SEE THE SIDING AND PAVEMENT MARKING PLANS (SPM DWGS.) FOR ADDITIONAL INFORMATION ON ROADWAY STORAGE AND PAVEMENT MARKING LAYOUT.
- SEE MISCELLANEOUS TABLES ON DWGS. MST-1.

**RIGHT-OF-WAY NOTES:**

- ALL WORK TO BE PERFORMED UNDER THIS CONTRACT WILL BE WITHIN THE PUBLIC RIGHT-OF-WAY (ROW) IN ACCORDANCE WITH SECTION 105-15 OF THE STANDARD SPECIFICATIONS. THE CONTRACTOR IS TO ASSURE HIMSELF THAT ALL WORK IS BEING PERFORMED WITHIN THE ROW, INCLUDING BUT NOT LIMITED TO VEHICLE ACCESS; STORAGE OF EQUIPMENT, MATERIALS, DEBRIS AND WASTE; LANDSCAPING; VEGETATION REMOVAL AND MANAGEMENT; GRADING, SEEDING AND THE INSTALLATION OF TURF; AND THE INSTALLATION OF ANY FENCES OR PROTECTIVE BARRIER.
- IF CONTRACTOR IS UNABLE TO IDENTIFY THE LIMITS OF THE RIGHTS-OF-WAY WHEN THE CONTRACT CALLS FOR WORK IN THOSE VICINITIES, THE CONTRACTOR MUST CONTACT THE PROJECT ENGINEER FOR DEFINITIVE BOUNDARY DETERMINATIONS BEFORE ANY WORK MAY BE INITIATED AT THOSE LOCATIONS (STANDARD SPECIFICATIONS SECTIONS 105-10 AND 625).
- IN ACCORDANCE WITH SECTION 105-15 OF THE STANDARD SPECIFICATIONS, RELEASES FOR ANY NON-ESSENTIAL CONTRACT WORK OUTSIDE OF THE EXISTING RIGHTS-OF-WAY, INCLUDING PLANTINGS, LANDSCAPING OR DRIVEWAY ENHANCEMENT, WILL BE PROVIDED BY THE PROJECT ENGINEER AND IN NO INSTANCE ARE TO BE SECURED BY THE CONTRACTOR. THE CONTRACTOR SHALL NOT INVADE UPON PRIVATE PROPERTIES, LANDS OR BUILDINGS OUTSIDE OF THE RIGHTS-OF-WAY FOR ANY REASON WITHOUT FIRST SECURING WRITTEN PERMISSION FROM THE PROPERTY OWNER (STANDARD SPECIFICATIONS SECTIONS 105-15).
- THE CONTRACTOR WILL BE HELD LIABLE FOR ANY DAMAGES DONE, ANY SUCH INJURIES OR DAMAGES SHALL BE SATISFACTORILY REPAIRED OR ITEMS REPLACED AT THE CONTRACTOR'S EXPENSE (STANDARD SPECIFICATIONS SECTION 107-08).



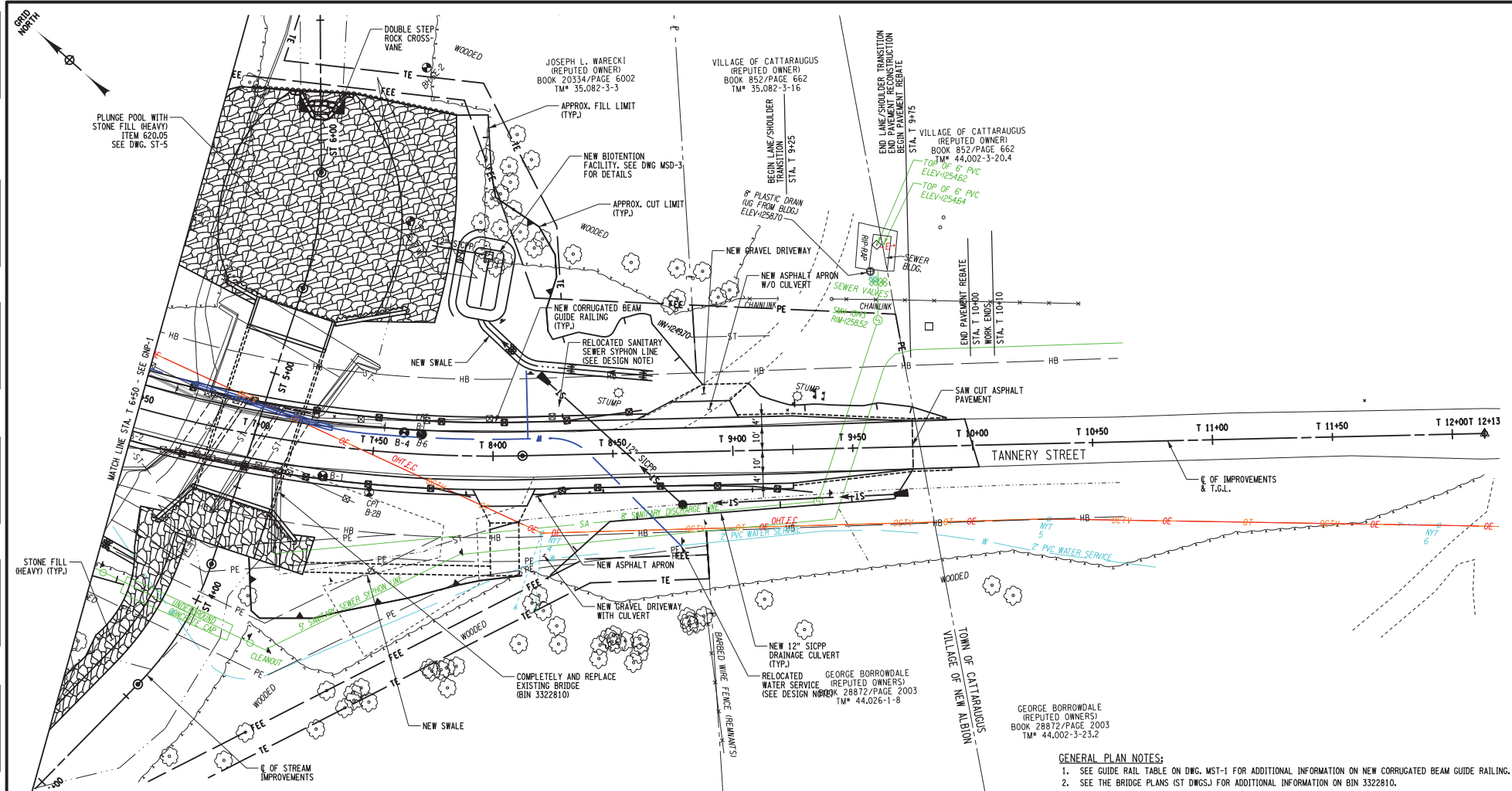
AFFIX SEAL: ON:	ALTERED BY: ON:

AS-BUILT REVISIONS DESCRIPTION OF ALTERATIONS:	TANNERY STREET OVER TRIB. S. BR. CATTARAUGUS CREEK	PIN 5757.33	BRIDGES 3322810	CULVERTS	ALL DIMENSIONS IN FT UNLESS OTHERWISE NOTED
	VILLAGE OF CATTARAUGUS AND TOWN OF NEW ALBION				ROADWAY PLAN STA. T 1+00 TO ST
	COUNTY: CATTARAUGUS	REGION: 5			Cattaraugus County DPW LRB-2019-00398
IT IS A VIOLATION OF LAW FOR ANY PERSON, UNLESS THEY ARE ACTING UNDER THE DIRECTION OF A LICENSED PROFESSIONAL ENGINEER, ARCHITECT, LANDSCAPE ARCHITECT, OR LAND SURVEYOR, TO ALTER AN ITEM IN ANY WAY. IF AN ITEM BEARING THE STAMP OF A LICENSED PROFESSIONAL IS ALTERED, THE ALTERING ENGINEER, ARCHITECT, LANDSCAPE ARCHITECT, OR LAND SURVEYOR SHALL STAMP THE DOCUMENT AND INCLUDE THE NOTATION "ALTERED BY" FOLLOWED BY THEIR SIGNATURE, THE DATE OF SUCH ALTERATION, AND A SPECIFIC DESCRIPTION OF THE ALTERATION.					CATTARAUGUS COUNTY DEPARTMENT OF PUBLIC W



FILE NAME = I:\p1925001\28\Transportation\design\dwg\Plan\_Sep1920 - CWP-2.dwg  
 DATE/TIME = 7/6/2019 11:09:15 AM  
 USER = kborris

DESIGN SUPERVISOR T. BRADLEY  
 JOB MANAGER S. MILLER/T. BRADLEY DESIGN D. CLARK  
 S. MILLER/T. BRADLEY CHECK T. BRADLEY  
 DRAFTING D. CLARK  
 S. MILLER/T. BRADLEY CHECK T. BRADLEY  
 PROJECT MANAGER T. BRADLEY



- GENERAL PLAN NOTES:**
1. SEE GUIDE RAIL TABLE ON DWG. MST-1 FOR ADDITIONAL INFORMATION ON NEW CORRUGATED BEAM GUIDE RAILING.
  2. SEE THE BRIDGE PLANS (ST DWGS.) FOR ADDITIONAL INFORMATION ON BIN 3322810.
  3. SEE THE SURVEY CONTROL SHEET (DWG. SCS-1) FOR ADDITIONAL INFORMATION ON THE HORIZONTAL ALIGNMENT, SURVEY BASELINE, AND BENCHMARKS.
  4. SEE THE EROSION AND SEDIMENT CONTROL PLAN (DWG. ECP-1) FOR ADDITIONAL INFORMATION ON EROSION AND SEDIMENT CONTROL FOR THIS PROJECT.
  5. SEE THE SIGNING AND PAVEMENT MARKING PLANS (SPM DWGS.) FOR ADDITIONAL INFORMATION ON ROADWAY SIGNAGE AND PAVEMENT MARKING LAYOUT.



AFFIX SEAL: ONE	ALTERED BY: ONE
JOSEPH L. WARECKI (REPUTED OWNER) BOOK 20334/PAGE 6002 TM# 35.082-5-8	

AS-BUILT REVISIONS DESCRIPTION OF ALTERATIONS:	TANNERY STREET OVER TRIB. S. BR. CATTARAUGUS CREEK VILLAGE OF CATTARAUGUS AND TOWN OF NEW ALBION	PIN 5757.33	BRIDGES 3322810	CULVERTS	ALL DIMENSIONS IN FT UNLESS OTHERWISE NOTED
	COUNTY: CATTARAUGUS	REGION: 5			ROADWAY PLAN STA. T 6+50 TO STA. 12+13

IT IS A VIOLATION OF LAW FOR ANY PERSON, UNLESS THEY ARE ACTING UNDER THE DIRECTION OF A LICENSED PROFESSIONAL ENGINEER, ARCHITECT, LANDSCAPE ARCHITECT, OR LAND SURVEYOR, TO ALTER AN ITEM IN ANY WAY. IF AN ITEM BEARING THE STAMP OF A LICENSED PROFESSIONAL IS ALTERED, THE ALTERING ENGINEER, ARCHITECT, LANDSCAPE ARCHITECT, OR LAND SURVEYOR SHALL STAMP THE DOCUMENT AND INCLUDE THE NOTATION "ALTERED BY" FOLLOWED BY THEIR SIGNATURE, THE DATE OF SUCH ALTERATION, AND A SPECIFIC DESCRIPTION OF THE ALTERATION.	
--	--

CATTARAUGUS COUNTY DEPARTMENT OF PUBLIC WORKS	
--	--

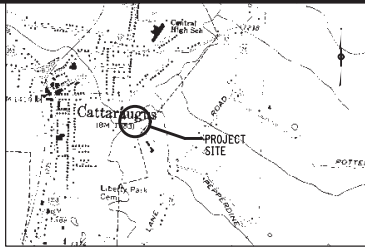
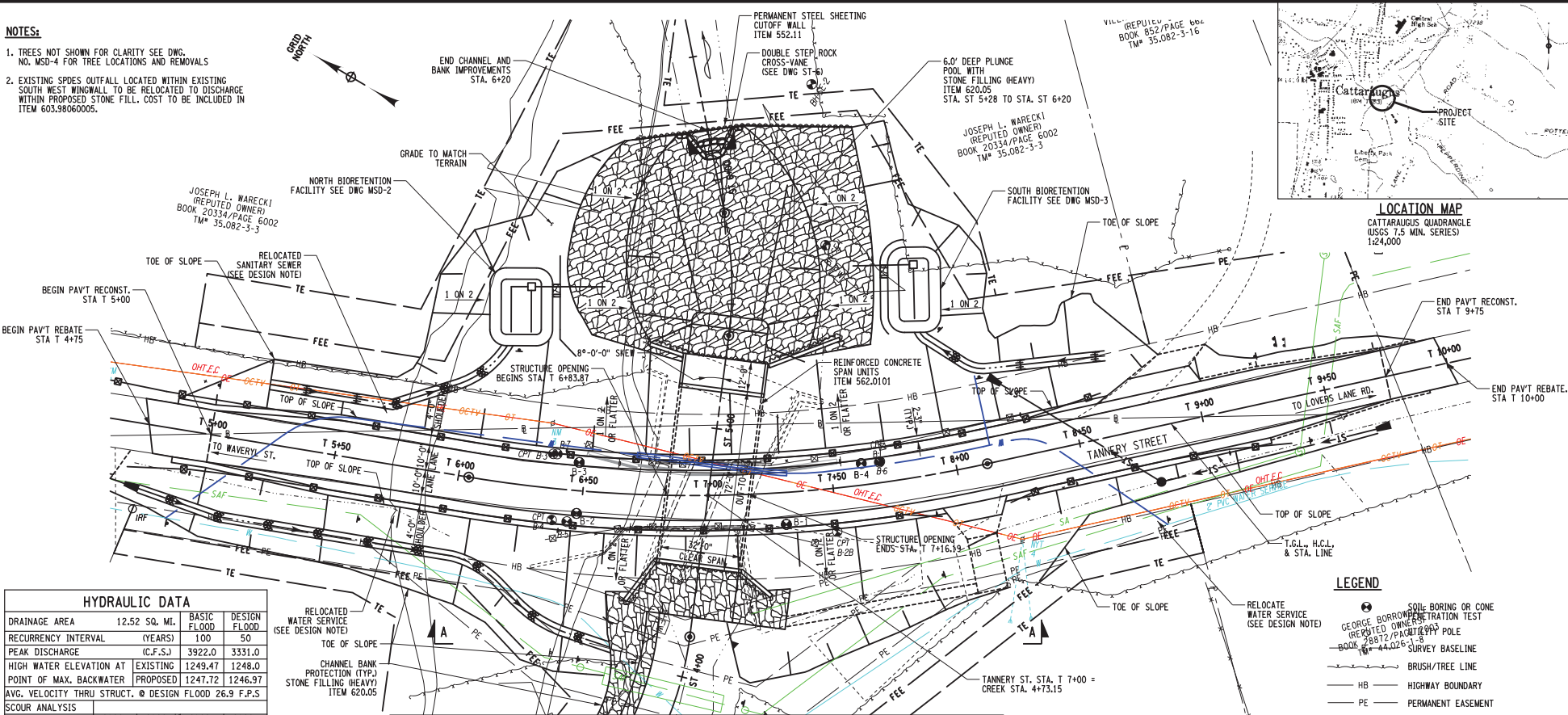
CATTARAUGUS COUNTY DPW LRB-2019-00398 Sheet 12 of 21	
--	--

FILE NAME = I:\p1925001\26structure\cadd\grading\dwg\PlanSet\PS1-1.dgn  
 DATE/TIME = 3/6/2019 11:46:01 AM  
 USER = kborris

DESIGN SUPERVISOR T. BRADLEY  
 JOB MANAGER S. MILLER/T. BRADLEY  
 DESIGN D. CLARK  
 DRAFTING D. CLARK  
 CHECK T. BRADLEY  
 S. MILLER/T. BRADLEY  
 PROJECT MANAGER T. BRADLEY

**NOTES:**

- TREES NOT SHOWN FOR CLARITY SEE DWG. NO. MSD-4 FOR TREE LOCATIONS AND REMOVALS
- EXISTING SPDES OUTFALL LOCATED WITHIN EXISTING SOUTH WEST WINGWALL TO BE RELOCATED TO DISCHARGE WITHIN PROPOSED STONE FILL. COST TO BE INCLUDED IN ITEM 603.9060005.

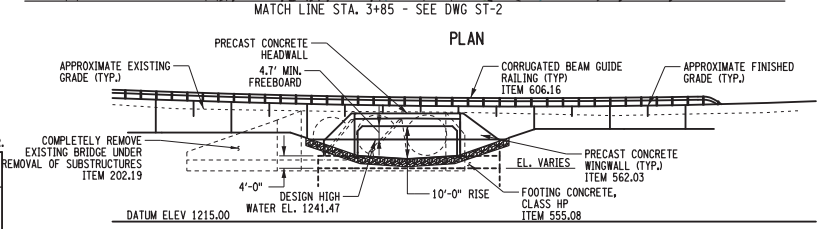


HYDRAULIC DATA				
DRAINAGE AREA	12.52 SQ. MI.	BASIC FLOOD	DESIGN FLOOD	
RECURRENTY INTERVAL (YEARS)	100	50		
PEAK DISCHARGE (C.F.S.)	3922.0	3331.0		
HIGH WATER ELEVATION AT EXISTING	1249.47	1248.0		
POINT OF MAX. BACKWATER	PROPOSED 1247.72	1246.97		
AVG. VELOCITY THRU STRUCT.	DESIGN FLOOD 26.9 F.P.S.			
SCOUR ANALYSIS				
MINIMUM CHANNEL ELEVATION (FT.)	Q100 SCOUR DEPTH (FT.)	Q100 SCOUR DEPTH (FT.)	Q100 SCOUR DEPTH (FT.)	Q100 SCOUR DEPTH (FT.)
INLET - 1235.18	7.957	1227.22	8.591	1226.58
OUTLET - 1227.68	7.957	1219.72	8.591	1219.08

THE PROPOSED STRUCTURE SHALL HAVE A MINIMUM AREA OF 185 SF BELOW THE DESIGN HIGH WATER ELEVATION OF 1241.47 FT AT THE UPSTREAM FASCIA OF THE STRUCTURE. THIS AREA SHALL BE MEASURED PERPENDICULAR TO THE FLOW. THE MINIMUM CLEAR SPAN SHALL BE 32 FT PERPENDICULAR TO FLOW. A CLEAR SPAN EXCEEDING THIS BY MORE THAN 10% SHALL REQUIRE THE CONCURRENCE OF THE REGIONAL HYDRAULICS ENGINEER.

RELOCATED WATER SERVICE (SEE DESIGN NOTE)  
 TOE OF SLOPE  
 CHANNEL BANK PROTECTION (TYP.) STONE FILLING (HEAVY) ITEM 620.05

AFFIX SEAL:	ALTERED BY:
ON:	ON:



**DESIGN NOTE**  
 SANITARY SEWER AND WATER SERVICE RELOCATION TO BE DESIGNED BY CATTARAUGUS COUNTY. LOCATION AND DETAIL DRAWINGS WILL BE PROVIDED TO STANTEC.

- LEGEND**
- SOIL BORING OR CORE
  - GEORGE BORROW PITRATION TEST (REPUTED OWNER) POLE
  - BOOK 28812/PAGE 11-13
  - ITEM 44.026-1-3
  - SURVEY BASELINE
  - BUSH/TREE LINE
  - HB HIGHWAY BOUNDARY
  - PE PERMANENT EASEMENT
  - OE OVERHEAD ELECTRIC
  - OT OVERHEAD TELEPHONE
  - OCTV OVERHEAD CABLE
  - W UNDERGROUND WATER
  - SAF UNDERGROUND SEWER
  - FEE FEE ACQUISITION
  - TE TEMPORARY EASEMENT
  - PE PERMANENT EASEMENT
  - SAF PROPOSED UNDERGROUND SEWER
  - W UNDERGROUND WATER
  - ST SEWER, STORM
  - GR GUIDE RAIL



AS-BUILT REVISIONS DESCRIPTION OF ALTERATIONS:	TANNERY STREET OVER TRIB. S. BR. CATTARAUGUS CREEK VILLAGE OF CATTARAUGUS AND TOWN OF NEW ALBION	PIN 5757.33	BRIDGES 3322810	CULVERTS	ALL DIMENSIONS IN FT UNLESS OTHERWISE NOTED
	COUNTY: CATTARAUGUS	REGION: 5	GENERAL PLAN & ELEVATION		
IT IS A VIOLATION OF LAW FOR ANY PERSON, UNLESS THEY ARE ACTING UNDER THE DIRECTION OF A LICENSED PROFESSIONAL ENGINEER, ARCHITECT, LANDSCAPE ARCHITECT, OR LAND SURVEYOR, TO ALTER AN ITEM IN ANY WAY, IF AN ITEM BEARING THE STAMP OF A LICENSED PROFESSIONAL IS ALTERED, THE ALTERING ENGINEER, ARCHITECT, LANDSCAPE ARCHITECT, OR LAND SURVEYOR SHALL STAMP THE DOCUMENT AND INCLUDE THE NOTATION "ALTERED BY" FOLLOWED BY THEIR SIGNATURE, THE DATE OF SUCH ALTERATION, AND A SPECIFIC DESCRIPTION OF THE ALTERATION.					

Cattaraugus County DPW  
 LRB-2019-00398  
 Sheet 13 of 21



FILE NAME = I:\192500172\structure\dwg\grading\wing\PlanSet\FST-2.dgn  
 DATE/TIME = 2/7/2019 8:06:21 AM  
 USER = kborris

DESIGN SUPERVISOR T. BRADLEY PROJECT MANAGER T. BRADLEY  
 S. MILLER / CHECK T. BRADLEY  
 S. MILLER / CHECK T. BRADLEY  
 DRAFTING D. CLARK  
 DESIGN D. CLARK  
 JOB MANAGER S. MILLER/T. BRADLEY

**GENERAL NOTES**

DESIGN SPECIFICATIONS: NYSDOT LRFD BRIDGE DESIGN SPECIFICATIONS WITH ALL PROVISIONS IN EFFECT AS OF JANUARY 2019 (FOR DESIGN PURPOSES, COMPRESSIVE STRENGTH OF CONCRETE FOR SUBSTRUCTURES AND DECK SLABS AT 28 DAYS:  $f_c = 3000$  psi.)

LIVE LOAD: AASHTO HL - 93 AND NYSDOT DESIGN PERMIT VEHICLE.

CONSTRUCTION AND MATERIALS SPECIFICATIONS: STANDARD SPECIFICATIONS, CONSTRUCTION AND MATERIALS, NEW YORK STATE DEPARTMENT OF TRANSPORTATION, OFFICE OF ENGINEERING.

DETAILS ON THE DRAWINGS LABELED AS "NOT TO SCALE" ARE INTENTIONALLY DRAWN NOT TO SCALE FOR VISUAL CLARITY. ALL OTHER DETAILS FOR WHICH NO SCALE IS SHOWN ARE DRAWN PROPORTIONAL AND ARE FULLY DIMENSIONED.

ALL SHOP DRAWINGS SUBMITTED FOR THIS PROJECT SHALL BE IN US CUSTOMARY UNITS.

THE COST OF ALL JOINT MATERIAL SHALL BE INCLUDED IN THE UNIT PRICES BID FOR THE VARIOUS ITEMS OF THE CONTRACT, UNLESS OTHERWISE SPECIFIED ON THE PLANS.

DIMENSIONS OF THICKNESSES OF STEEL ROLLED ANGLE SHAPES AND STRUCTURAL TUBING ARE SHOWN ACCORDING TO THE AISC MANUAL.

THIS BRIDGE SHALL BE MAINTAINED IN ACCORDANCE WITH THE GUIDELINES CONTAINED IN THE CURRENT EDITION OF THE AASHTO MAINTENANCE MANUAL FOR ROADWAYS AND BRIDGES.

THE LOAD RATINGS ARE IN ACCORDANCE WITH THE AASHTO MANUAL FOR BRIDGE EVALUATION.

**FOUNDATION NOTES**

ALL PLACEMENTS OF SELECT STRUCTURE FILL, ITEM 203.21, SHALL BE COMPACTED TO 95 PERCENT OF STANDARD PROCTOR MAXIMUM DENSITY.

HIGHWAY EMBANKMENT MATERIAL (FROM HIGHWAY ESTIMATE OR FROM STRUCTURE EXCAVATION BACKFILL) AND SELECT STRUCTURE FILL, ITEM 203.2, SHALL BE PLACED SIMULTANEOUSLY, IN CONTACT, ON BOTH SIDES OF THE VERTICAL PAYMENT LINE.

THE COST OF WATER USED FOR COMPACTION OF SELECT FILL ITEMS SHALL BE INCLUDED IN THE UNIT PRICE BID FOR ITEM 203.21 - SELECT STRUCTURE FILL.

**COFFERDAM NOTES**

SHOULD THE CONTRACTOR ELECT TO LAY BACK A PORTION OF THE EXISTING EARTH ADJACENT TO AN EXCAVATION REQUIRING A COFFERDAM, ANY REQUIRED EXTENSIONS OF THE COFFERDAM NECESSARY TO KEEP WATER FROM ENTERING THE EXCAVATION SHALL BE FURNISHED AND PLACED AT NO COST TO THE COUNTY.

WHERE A COFFERDAM IS USED, THE COST OF DEWATERING THE ENTIRE EXCAVATION, REGARDLESS OF SOURCE OF WATER, SHALL BE INCLUDED IN THE UNIT PRICE BID FOR THE COFFERDAM ITEM.

SHOULD FIELD CONDITIONS REQUIRE A CHANGE FROM THE TYPE OF COFFERDAM SYSTEM CALLED FOR ON THE PLANS, THE ENGINEER-IN-CHARGE SHALL CONTACT THE ENGINEER FOR COORDINATION WITH APPROPRIATE AGENCIES TO APPROVE THE CHANGE.

IF MULTIPLE COFFERDAMS ARE REPLACED BY A SINGLE SYSTEM, AS PERMITTED BY THE ENGINEER, PAYMENT SHALL BE BASED ON ALL OF THE APPLICABLE COFFERDAM ITEMS INDICATED ON THE PLANS.

DEWATERING OF THE COFFERDAM SHALL BE ACCOMPLISHED BY PUMPING THE WATER TO AN APPROVED UPLAND VEGETATED AREA OUTSIDE OF THE STREAMBED AS SHOWN ON THE PLANS AND/OR APPROVED BY THE E.I.G. TEMPORARY SOIL EROSION AND WATER POLLUTION CONTROL, SUCH AS STRAW BALES OR APPROVED EQUAL, MAY BE REQUIRED AS DETERMINED BY THE ENGINEER-IN-CHARGE. NO SETTLEMENT BASIN SHALL BE CONSTRUCTED.

ORDINARY HIGH WATER IS ESTIMATED TO BE 1238.07 AT THE BRIDGE. THIS IS DEFINED AS THE WATER SURFACE ELEVATION FOR THE MEAN ANNUAL FLOOD, WHICH IS THE FLOOD THAT HAS A RECURRENCE INTERVAL OF 2.33 YEARS.

ORDINARY WATER IS ESTIMATED TO BE 1237.50 AT THE BRIDGE. THIS IS DEFINED AS THE HIGHEST SURFACE WATER ELEVATION LIKELY TO BE ENCOUNTERED DURING ONE CONSTRUCTION SEASON (OTHER THAN MAJOR FLOODS). IT IS ALWAYS LESS THAN THE ORDINARY HIGH WATER ELEVATION AND IT IS USUALLY AN OBSERVED ELEVATION RATHER THAN A COMPUTED ONE.

LOW WATER IS ESTIMATED TO BE 1237.23 AT THE BRIDGE. THIS WATER ELEVATION IS THE NORMAL LOW WATER ELEVATION PREVALENT DURING ONE CONSTRUCTION SEASON FOR MORE THAN 25% OF THE TIME. IT IS AN OBSERVED ELEVATION RATHER THAN A COMPUTED ONE.

**REMOVAL NOTES**

EXISTING SUBSTRUCTURES SHALL BE REMOVED WITHIN THE LIMITS SHOWN ON THE PLANS UNDER ITEM 202.19 IN THE BRIDGE ESTIMATE.

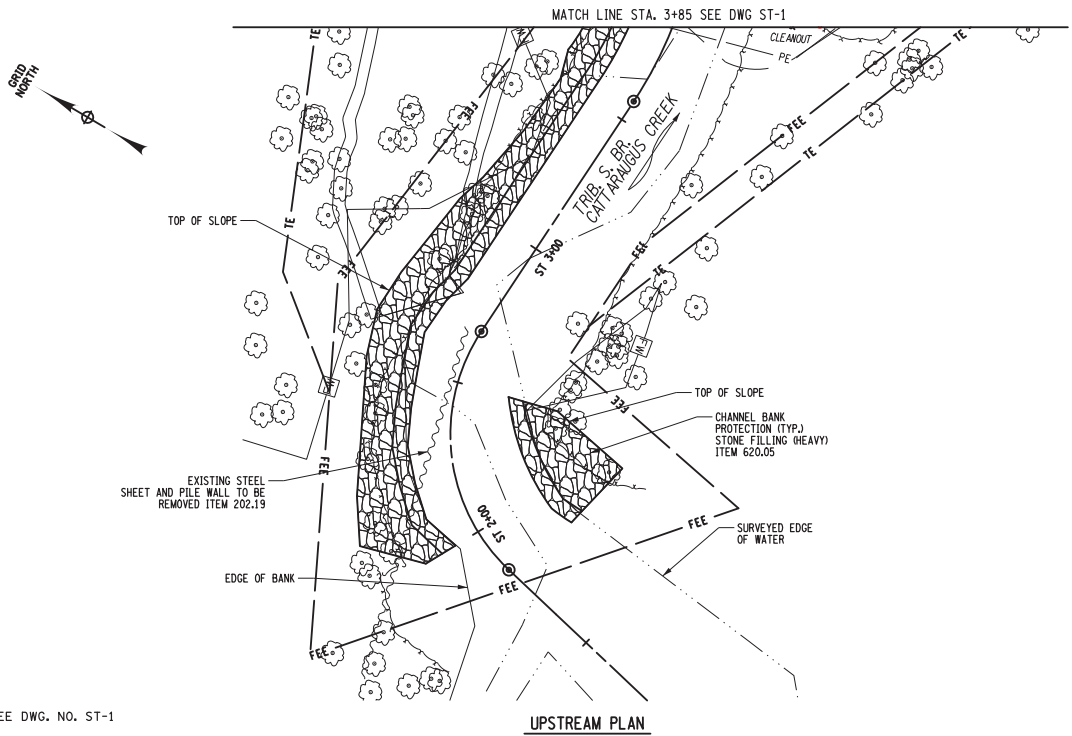
THE CONTRACTOR'S ATTENTION IS DIRECTED TO THE REQUIREMENTS OF SUBSECTION 202.3-01 GENERAL AND SAFETY REQUIREMENTS. A REMOVAL PLAN, SIGNED BY A LICENSED AND REGISTERED PROFESSIONAL ENGINEER IN THE STATE OF NEW YORK, SHALL BE SUBMITTED TO THE ENGINEER THIRTY (30) DAYS PRIOR TO BEGINNING THE DEMOLITION.

RECORD PLANS FOR THIS STRUCTURE ARE NOT AVAILABLE.

REFER TO SUBSECTION 107-05 OF THE STANDARD SPECIFICATIONS FOR SAFETY AND HEALTH REQUIREMENTS.

**INDEX OF DRAWINGS**

- ST-1 GENERAL PLAN AND ELEVATION
- ST-2 GENERAL NOTES AND UPSTREAM PLAN
- ST-3 DEMOLITION, EXCAVATION AND EMBANKMENT PLAN
- ST-4 DEMOLITION, EXCAVATION AND EMBANKMENT SECTIONS
- ST-5 DEMOLITION, EXCAVATION AND EMBANKMENT SECTIONS
- ST-6 CONCEPTUAL TEMPORARY WATERWAY PLAN AND PROFILE
- ST-7 CONCEPTUAL TEMPORARY WATERWAY SECTIONS
- ST-8 STRUCTURE PLAN AND SECTIONS
- ST-9 MAT FOUNDATION DETAILS
- ST-10 WINGWALL SECTIONS AND DETAILS
- ST-11 WINGWALL SECTIONS AND DETAILS
- ST-12 WINGWALL SECTIONS AND DETAILS



**NOTE:**  
 FOR LEGEND SEE DWG. NO. ST-1

AFFIX SEAL: ON:	ALTERED BY: ON:

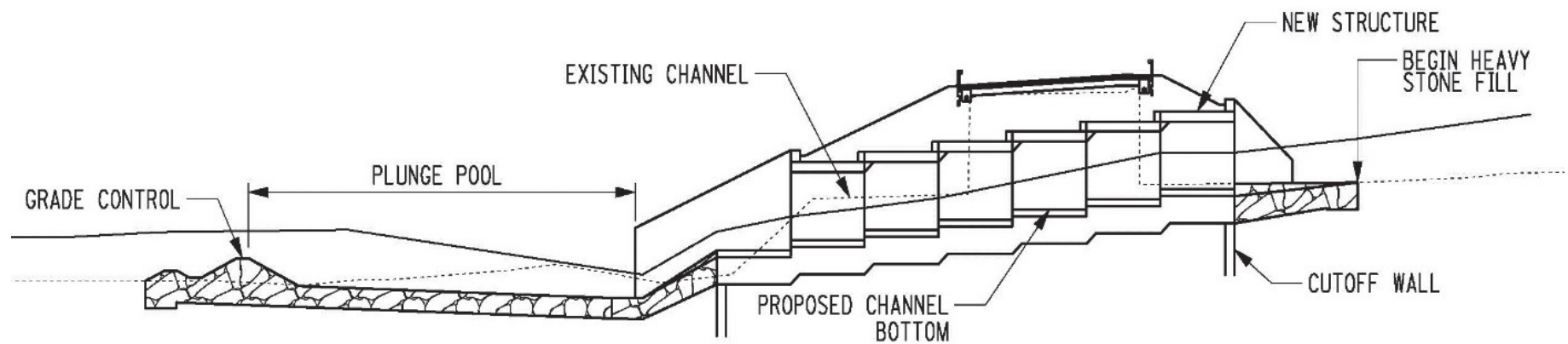
AS-BUILT REVISIONS DESCRIPTION OF ALTERATIONS:	TANNERY STREET OVER TRIB. S. BR. CATTARAUGUS CREEK VILLAGE OF CATTARAUGUS AND TOWN OF NEW ALBION	PIN 5757.33	BRIDGES 3322810	CULVERTS	ALL DIMENSIONS IN FT UNLESS OTHERWISE NOTED
	COUNTY: CATTARAUGUS	REGION: 5			

GENERAL NO AND UPSTREAM  
 Cattaraugus County DPW  
 LRB-2019-00398  
 Sheet 14 of 21

IT IS A VIOLATION OF LAW FOR ANY PERSON, UNLESS THEY ARE ACTING UNDER THE DIRECTION OF A LICENSED PROFESSIONAL ENGINEER, ARCHITECT, LANDSCAPE ARCHITECT, OR LAND SURVEYOR, TO ALTER AN ITEM IN ANY WAY. IF AN ITEM BEARING THE STAMP OF A LICENSED PROFESSIONAL IS ALTERED, THE ALTERING ENGINEER, ARCHITECT, LANDSCAPE ARCHITECT, OR LAND SURVEYOR SHALL STAMP THE DOCUMENT AND INCLUDE THE NOTATION "ALTERED BY" FOLLOWED BY THEIR SIGNATURE, THE DATE OF SUCH ALTERATION, AND A SPECIFIC DESCRIPTION OF THE ALTERATION.

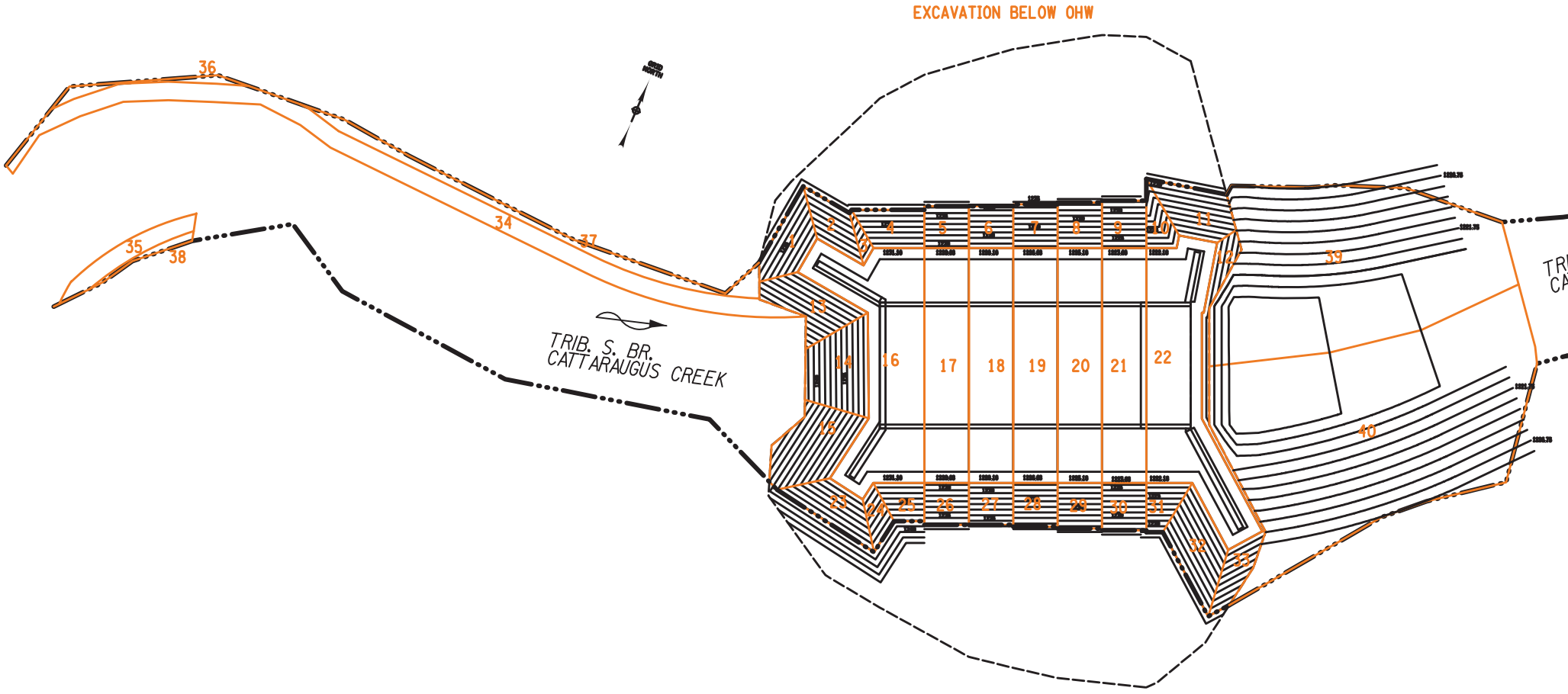
# HYDRAULIC ANALYSIS FOR TANNERY STREET OVER TRIB. SOUTH BRANCH CATTARAUGUS CREEK

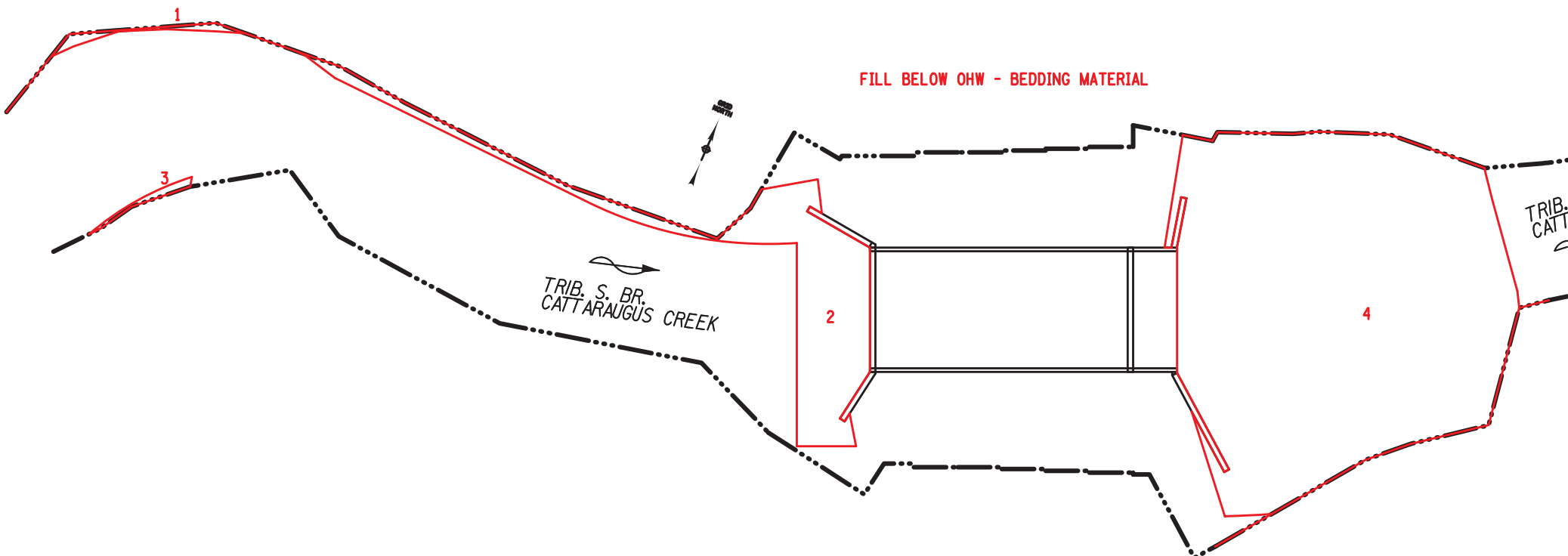
November 3, 2017

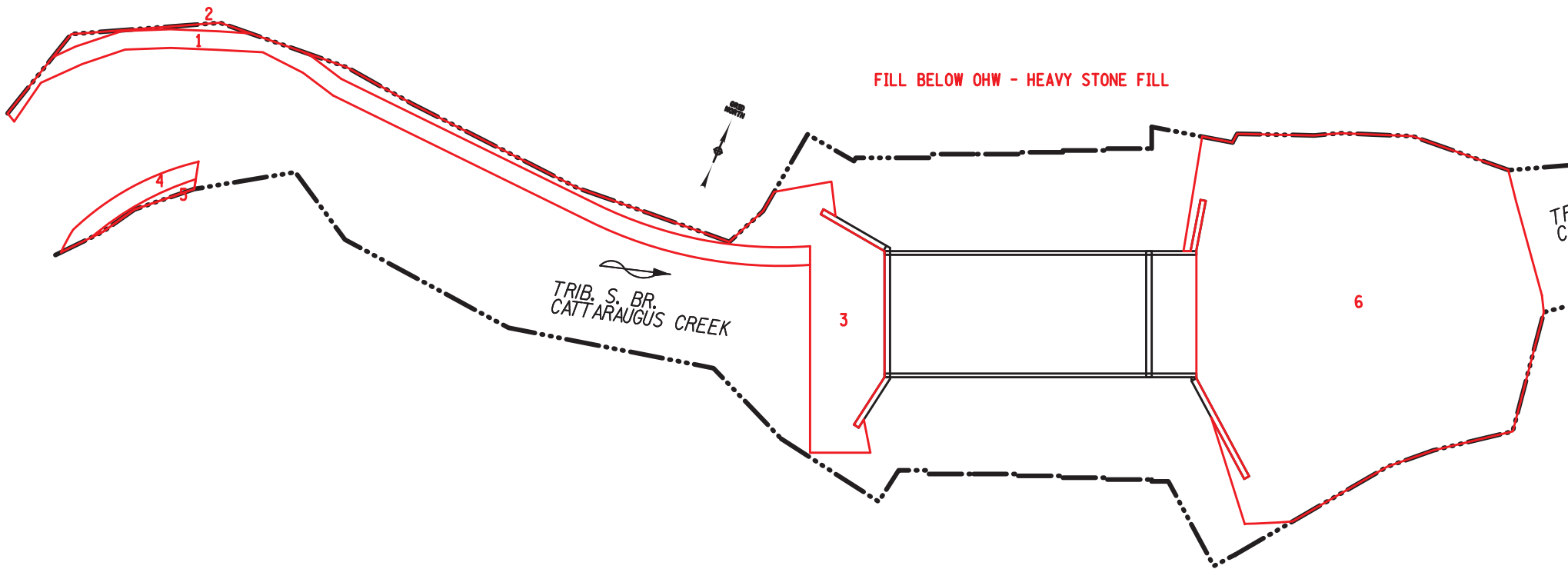


**Figure 5: Proposed Channel Profile**

Cattaraugus County DPW  
LRB-2019-00398  
Sheet 15 of 21

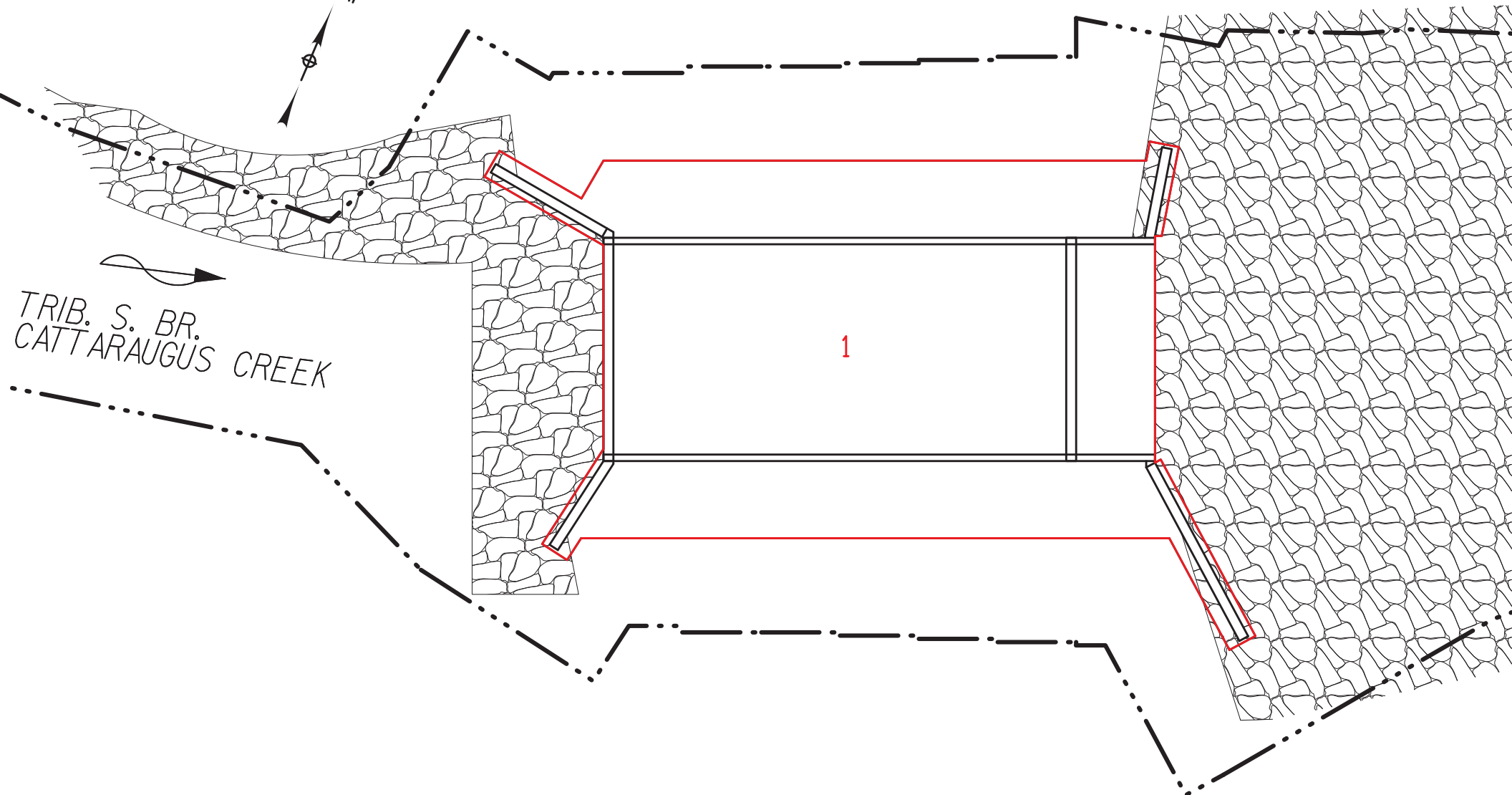






FILL BELOW OHW - POURED CONCRETE

GRID  
NORTH

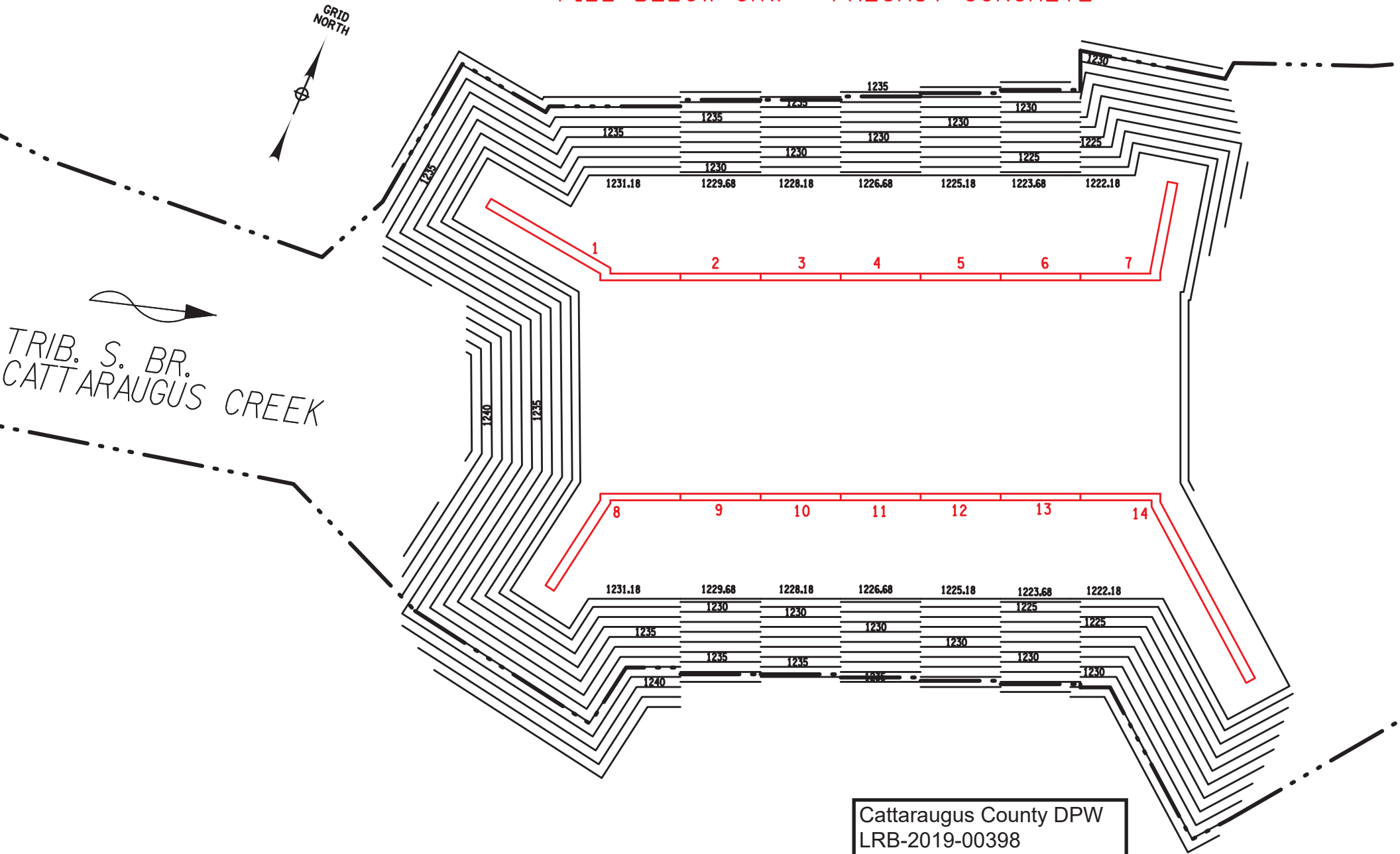


TRIB. S. BR.  
CATTARAUGUS CREEK

1

Cattaraugus County DPW  
LRB-2019-00398  
Sheet 19 of 21

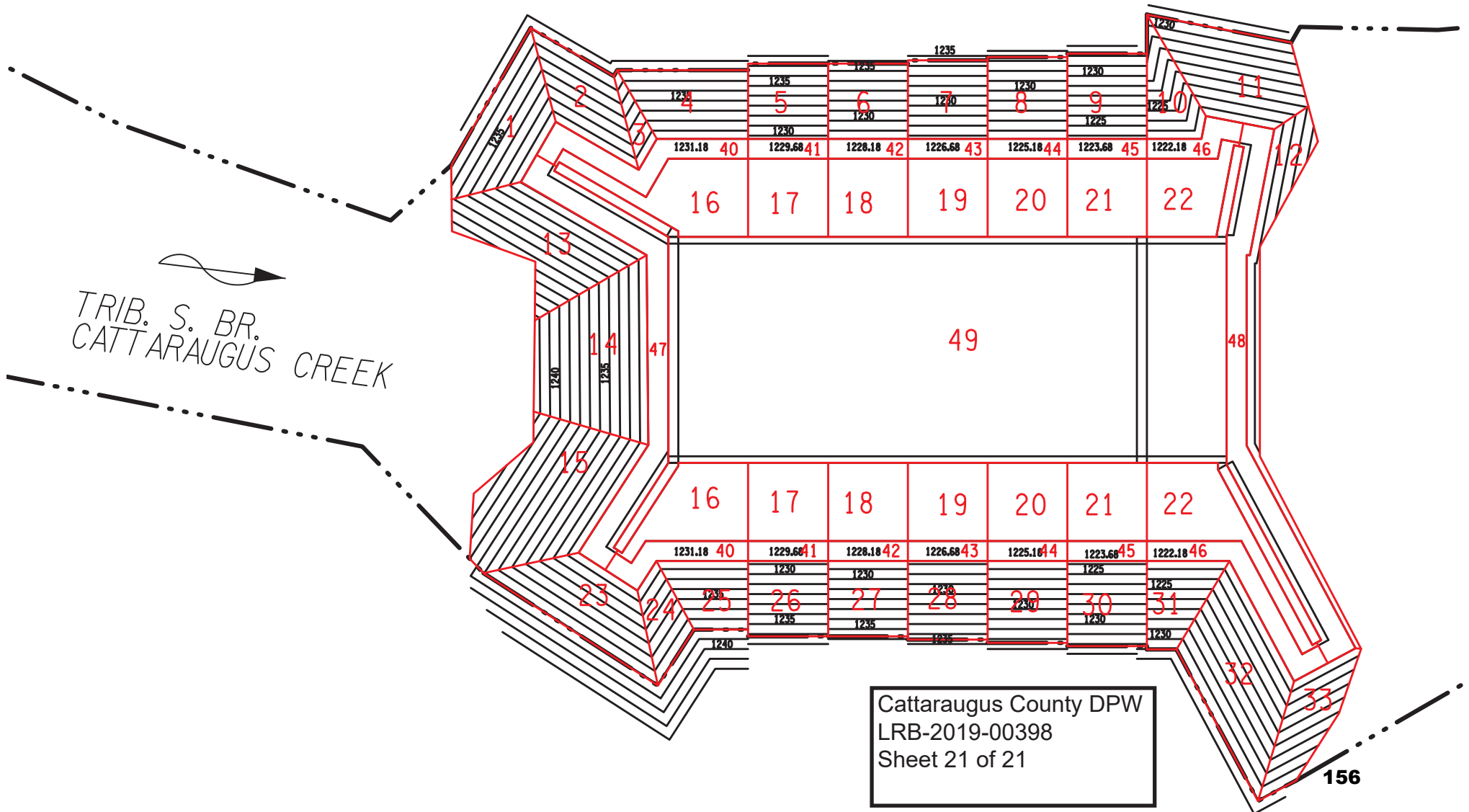
FILL BELOW OHW - PRECAST CONCRETE



Cattaraugus County DPW  
LRB-2019-00398  
Sheet 20 of 21



FILL BELOW OHW - STRUCTURE FILL/EMBANKMENT/BACKFILL



TRIB. S. BR.  
CATTARAUGUS CREEK

Cattaraugus County DPW  
LRB-2019-00398  
Sheet 21 of 21



**ACTIVITIES AUTHORIZED BY 2017 NATIONWIDE PERMIT  
WITHIN THE STATE OF NEW YORK  
Expiration March 18, 2022**

**B. Nationwide Permits**

**3. Maintenance.** (a) The repair, rehabilitation, or replacement of any previously authorized, currently serviceable structure or fill, or of any currently serviceable structure or fill authorized by 33 CFR 330.3, provided that the structure or fill is not to be put to uses differing from those uses specified or contemplated for it in the original permit or the most recently authorized modification. Minor deviations in the structure's configuration or filled area, including those due to changes in materials, construction techniques, requirements of other regulatory agencies, or current construction codes or safety standards that are necessary to make the repair, rehabilitation, or replacement are authorized. This NWP also authorizes the removal of previously authorized structures or fills. Any stream channel modification is limited to the minimum necessary for the repair, rehabilitation, or replacement of the structure or fill; such modifications, including the removal of material from the stream channel, must be immediately adjacent to the project. This NWP also authorizes the removal of accumulated sediment and debris within, and in the immediate vicinity of, the structure or fill. This NWP also authorizes the repair, rehabilitation, or replacement of those structures or fills destroyed or damaged by storms, floods, fire or other discrete events, provided the repair, rehabilitation, or replacement is commenced, or is under contract to commence, within two years of the date of their destruction or damage. In cases of catastrophic events, such as hurricanes or tornadoes, this two-year limit may be waived by the district engineer, provided the permittee can demonstrate funding, contract, or other similar delays.

(b) This NWP also authorizes the removal of accumulated sediments and debris outside the immediate vicinity of existing structures (e.g., bridges, culverted road crossings, water intake structures, etc.). The removal of sediment is limited to the minimum necessary to restore the waterway in the vicinity of the structure to the approximate dimensions that existed when the structure was built, but cannot extend farther than 200 feet in any direction from the structure. This 200 foot limit does not apply to maintenance dredging to remove accumulated sediments blocking or restricting outfall and intake structures or to maintenance dredging to remove accumulated sediments from canals associated with outfall and intake structures. All dredged or excavated materials must be deposited and retained in an area that has no waters of the United States unless otherwise specifically approved by the district engineer under separate authorization.

(c) This NWP also authorizes temporary structures, fills, and work, including the use of temporary mats, necessary to conduct the maintenance activity. Appropriate measures must be taken to maintain normal downstream flows and minimize flooding to the maximum extent practicable, when temporary structures, work, and discharges, including cofferdams, are necessary for construction activities, access fills, or dewatering of construction sites. Temporary fills must consist of materials, and be placed in a manner, that will not be eroded by expected high flows. After conducting the maintenance activity, temporary fills must be removed in their entirety and the affected areas returned to pre-construction elevations. The areas affected by temporary fills must be revegetated, as appropriate.

(d) This NWP does not authorize maintenance dredging for the primary purpose of navigation. This NWP does not authorize beach restoration. This NWP does not authorize new stream channelization or stream relocation projects.

**Notification:** For activities authorized by paragraph (b) of this NWP, the permittee must submit a pre-construction notification to the district engineer prior to commencing the activity (see general condition 32). The pre-construction notification must include information regarding the original design capacities and configurations of the outfalls, intakes, small impoundments, and canals. (Authorities: Section 10 of the Rivers and Harbors Act of 1899 and section 404 of the Clean Water Act (Sections 10 and 404))

**Note:** This NWP authorizes the repair, rehabilitation, or replacement of any previously authorized structure or fill that does not qualify for the Clean Water Act section 404(f) exemption for maintenance.

**Permit-specific Regional Conditions (Buffalo and New York Districts):**

a. The Nationwide General Permit Condition No. 32 – Pre-Construction Notification (PCN) for activities proposed under NWP 3.b. involving the removal of accumulated sediments and debris in the vicinity of existing structures to restore the waterway to previously existing depths, must include evidence of such depths. Such evidence may include but is not limited to: construction drawings of the original structure; or project drawings of past excavation activities in the vicinity. If this information is not available, the PCN must include evidence of the existing depths immediately outside the proposed work area.

b. Every effort should be made to prevent additional encroachment into the beds of New York waterbodies. All repair or rehabilitation activities should focus on using the area immediately landward of the existing structure. Bulkhead replacement shall be completed in-place or landward of the existing structure where practicable. When that is not practicable, a PCN shall be required for any encroachment proposed within tidal waters of the U.S. or any extensions, excluding the placement of toe stone protection recommended/required by state/federal resource agencies (i.e. NYSDEC, NYSDOS, USFWS & USEPA), which exceed 18 inches waterward of the existing bulkhead within non-tidal waters. The PCN must include justification for a waterward extension of the bulkhead (e.g geologic conditions, engineering requirements, etc).

**REMINDER TO APPLICANT: For projects involving culvert maintenance or replacement, please take particular note of the requirements of General Regional Conditions G-B.1 and B.2. below. For projects involving aerial transmission lines, note clearance requirements as outlined in 33 CFR 322.5(i) (See NWP #12).**

**Section 401 Water Quality Certification:**

The New York State Department of Environmental Conservation (NYSDEC) has granted blanket Section 401 Water Quality Certification in New York State provided that the project complies with **all** the General Conditions listed below in Section H. Any party conducting the activities authorized by this NWP that cannot comply with **all** these conditions must apply for and obtain an individual Section 401 Water Quality Certification from the NYSDEC.

## **New York State Department of State Coastal Zone Management Consistency Determination:**

Pursuant to 15 CFR Part 930.41 and 930.43, the New York State Department of State (NYSDOS) concurs with the USACE consistency determination for this NWP with which all general and all Buffalo and New York District regional conditions are complied and with the additional condition(s), as follows:

The NYSDOS concurs with the USACE' consistency determination for NWP 3 outside of tidal wetlands and within the NYS Coastal Area where the activities to be authorized would: involve the repair/replacement in-place or landward, with no waterward expansion or increase in footprint; or for those proposed within the artificial canals identified by NYSDOS at:

[https://appext20.dos.ny.gov/coastal\\_map\\_public/map.aspx](https://appext20.dos.ny.gov/coastal_map_public/map.aspx).

### C. Nationwide Permit General Conditions

Note: To qualify for NWP authorization, the prospective permittee must comply with the following General Conditions, as applicable, in addition to any regional or case-specific conditions imposed by the division engineer or district engineer. Prospective permittees should contact the appropriate Corps district office to determine if regional conditions have been imposed on an NWP. Prospective permittees should also contact the appropriate Corps district office to determine the status of Clean Water Act Section 401 water quality certification and/or Coastal Zone Management Act consistency for an NWP. Every person who may wish to obtain permit authorization under one or more NWPs, or who is currently relying on an existing or prior permit authorization under one or more NWPs, has been and is on notice that all of the provisions of 33 CFR 330.1 through 330.6 apply to every NWP authorization. Note especially 33 CFR 330.5 relating to the modification, suspension, or revocation of any NWP authorization.

1. Navigation. (a) No activity may cause more than a minimal adverse effect on navigation.

(b) Any safety lights and signals prescribed by the U.S. Coast Guard, through regulations or otherwise, must be installed and maintained at the permittee's expense on authorized facilities in navigable waters of the United States.

(c) The permittee understands and agrees that, if future operations by the United States require the removal, relocation, or other alteration, of the structure or work herein authorized, or if, in the opinion of the Secretary of the Army or his authorized representative, said structure or work shall cause unreasonable obstruction to the free navigation of the navigable waters, the permittee will be required, upon due notice from the Corps of Engineers, to remove, relocate, or alter the structural work or obstructions caused thereby, without expense to the United States. No claim shall be made against the United States on account of any such removal or alteration.

2. Aquatic Life Movements. No activity may substantially disrupt the necessary life cycle movements of those species of aquatic life indigenous to the waterbody, including those species that normally migrate through the area, unless the activity's primary purpose is to impound water. All permanent and temporary crossings of waterbodies shall be suitably culverted, bridged, or otherwise designed and constructed to maintain low flows to sustain the movement of those aquatic species. If a bottomless culvert cannot be used, then the crossing should be designed and constructed to minimize adverse effects to aquatic life movements.

3. Spawning Areas. Activities in spawning areas during spawning seasons must be avoided to the maximum extent practicable. Activities that result in the physical destruction (e.g., through excavation, fill, or downstream smothering by substantial turbidity) of an important spawning area are not authorized.

4. Migratory Bird Breeding Areas. Activities in waters of the United States that serve as breeding areas for migratory birds must be avoided to the maximum extent practicable.

5. Shellfish Beds. No activity may occur in areas of concentrated shellfish populations, unless the activity is directly related to a shellfish harvesting activity authorized by NWP #4 and #48, or is a shellfish seeding or habitat restoration activity authorized by NWP #27.

6. Suitable Material. No activity may use unsuitable material (e.g., trash, debris, car bodies, asphalt, etc.). Material used for construction or discharged must be free from toxic pollutants in toxic amounts (see Section 307 of the Clean Water Act).

7. Water Supply Intakes. No activity may occur in the proximity of a public water supply intake, except where the activity is for the repair or improvement of public water supply intake structures or adjacent bank stabilization.

8. Adverse Effects From Impoundments. If the activity creates an impoundment of water, adverse effects to the aquatic system due to accelerating the passage of water, and/or restricting its flow must be minimized to the maximum extent practicable.

9. Management of Water Flows. To the maximum extent practicable, the pre-construction course, condition, capacity, and location of open waters must be maintained for each activity, including stream channelization, storm water management activities, and temporary and permanent road crossings, except as provided below. The activity must be constructed to withstand expected high flows. The activity must not restrict or impede the passage of normal or high flows, unless the primary purpose of the activity is to impound water or manage high flows. The activity may alter the pre-construction course, condition, capacity, and location of open waters if it benefits the aquatic environment (e.g., stream restoration or relocation activities).

10. Fills Within 100-Year Floodplains. The activity must comply with applicable FEMA-approved state or local floodplain management requirements.

11. Equipment. Heavy equipment working in wetlands or mudflats must be placed on mats, or other measures must be taken to minimize soil disturbance.

12. Soil Erosion and Sediment Controls. Appropriate soil erosion and sediment controls must be used and maintained in effective operating condition during construction, and all exposed soil and other fills, as well as any work below the ordinary high water mark or high tide line, must be permanently stabilized at the earliest practicable date. Permittees are encouraged to perform work within waters of the United States during periods of low-flow or no-flow, or during low tides.

13. Removal of Temporary Fills. Temporary fills must be removed in their entirety and the affected areas returned to pre-construction elevations. The affected areas must be revegetated, as appropriate.

14. Proper Maintenance. Any authorized structure or fill shall be properly maintained, including maintenance to ensure public safety and compliance with applicable NWP General Conditions, as well as any activity-specific conditions added by the district engineer to an NWP authorization.

15. Single and Complete Project. The activity must be a single and complete project. The same NWP cannot be used more than once for the same single and complete project.

16. Wild and Scenic Rivers. (a) No NWP activity may occur in a component of the National Wild and Scenic River System, or in a river officially designated by Congress as a "study river" for possible inclusion in the system while the river is in an official study status, unless the appropriate Federal agency with direct management responsibility for such river, has determined in writing that the proposed activity will not adversely affect the Wild and Scenic River designation or study status.

(b) If a proposed NWP activity will occur in a component of the National Wild and Scenic River System, or in a river officially designated by Congress as a "study river" for possible inclusion in the system while the river is in an official study status, the permittee must submit a pre-construction notification (see General Condition #32). The district engineer will coordinate the PCN with the Federal agency with direct management responsibility for that river. The permittee shall not begin the NWP activity until notified by the district engineer that the Federal

agency with direct management responsibility for that river has determined in writing that the proposed NWP activity will not adversely affect the Wild and Scenic River designation or study status.

(c) Information on Wild and Scenic Rivers may be obtained from the appropriate Federal land management agency responsible for the designated Wild and Scenic River or study river (e.g., National Park Service, U.S. Forest Service, Bureau of Land Management, U.S. Fish and Wildlife Service). Information on these rivers is also available at: <http://www.rivers.gov/>.

17. Tribal Rights. No NWP activity may cause more than minimal adverse effects on tribal rights (including treaty rights), protected tribal resources, or tribal lands.

18. Endangered Species. (a) No activity is authorized under any NWP which is likely to directly or indirectly jeopardize the continued existence of a threatened or endangered species or a species proposed for such designation, as identified under the Federal Endangered Species Act (ESA), or which will directly or indirectly destroy or adversely modify the critical habitat of such species. No activity is authorized under any NWP which "may affect" a listed species or critical habitat, unless ESA Section 7 consultation addressing the effects of the proposed activity has been completed. Direct effects are the immediate effects on listed species and critical habitat caused by the NWP activity. Indirect effects are those effects on listed species and critical habitat that are caused by the NWP activity and are later in time, but still are reasonably certain to occur.

(b) Federal agencies should follow their own procedures for complying with the requirements of the ESA. If pre-construction notification is required for the proposed activity, the Federal permittee must provide the district engineer with the appropriate documentation to demonstrate compliance with those requirements. The district engineer will verify that the appropriate documentation has been submitted. If the appropriate documentation has not been submitted, additional ESA Section 7 consultation may be necessary for the activity and the respective federal agency would be responsible for fulfilling its obligation under Section 7 of the ESA.

(c) Non-federal permittees must submit a pre-construction notification to the district engineer if any listed species or designated critical habitat might be affected or is in the vicinity of the activity, or if the activity is located in designated critical habitat, and shall not begin work on the activity until notified by the district engineer that the requirements of the ESA have been satisfied and that the activity is authorized. For activities that might affect Federally-listed endangered or threatened species or designated critical habitat, the pre-construction notification must include the name(s) of the endangered or threatened species that might be affected by the proposed activity or that utilize the designated critical habitat that might be affected by the proposed activity. The district engineer will determine whether the proposed activity "may affect" or will have "no effect" to listed species and designated critical habitat and will notify the non-Federal applicant of the Corps' determination within 45 days of receipt of a complete pre-construction notification. In cases where the non-Federal applicant has identified listed species or critical habitat that might be affected or is in the vicinity of the activity, and has so notified the Corps, the applicant shall not begin work until the Corps has provided notification that the proposed activity will have "no effect" on listed species or critical habitat, or until ESA Section 7 consultation has been completed. If the non-Federal applicant has not heard back from the Corps within 45 days, the applicant must still wait for notification from the Corps.

(d) As a result of formal or informal consultation with the FWS or NMFS the district engineer may add species-specific permit conditions to the NWPs.

(e) Authorization of an activity by an NWP does not authorize the "take" of a threatened or endangered species as defined under the ESA. In the absence of separate authorization (e.g., an ESA Section 10 Permit, a Biological Opinion with "incidental take" provisions, etc.) from the FWS or the NMFS, the Endangered Species Act prohibits any person subject to the jurisdiction of the United States to take a listed species, where "take" means to harass, harm, pursue, hunt, shoot, wound, kill, trap, capture, or collect, or to attempt to engage in any such conduct. The word "harm" in the definition of "take" means an act which actually kills or injures wildlife. Such an act may include significant habitat modification or degradation where it actually kills or injures wildlife by significantly impairing essential behavioral patterns, including breeding, feeding or sheltering.

(f) If the non-federal permittee has a valid ESA Section 10(a)(1)(B) incidental take permit with an approved Habitat Conservation Plan for a project or a group of projects that includes the proposed NWP activity, the non-federal applicant should provide a copy of that ESA Section 10(a)(1)(B) permit with the PCN required by paragraph (c) of this General Condition. The district engineer will coordinate with the agency that issued the ESA Section 10(a)(1)(B) permit to determine whether the proposed NWP activity and the associated incidental take were considered in the internal ESA Section 7 consultation conducted for the ESA Section 10(a)(1)(B) permit. If that coordination results in concurrence from the agency that the proposed NWP activity and the associated incidental take were considered in the internal ESA Section 7 consultation for the ESA Section 10(a)(1)(B) permit, the district engineer does not need to conduct a separate ESA Section 7 consultation for the proposed NWP activity. The district engineer will notify the non-federal applicant within 45 days of receipt of a complete pre-construction notification whether the ESA Section 10(a)(1)(B) permit covers the proposed NWP activity or whether additional ESA Section 7 consultation is required.

(g) Information on the location of threatened and endangered species and their critical habitat can be obtained directly from the offices of the FWS and NMFS or their world wide web pages at <http://www.fws.gov/> or <http://www.fws.gov/ipac> and <http://www.nmfs.noaa.gov/pr/species/esa/> respectively.

19. Migratory Birds and Bald and Golden Eagles. The permittee is responsible for ensuring their action complies with the Migratory Bird Treaty Act and the Bald and Golden Eagle Protection Act. The permittee is responsible for contacting appropriate local office of the U.S. Fish and Wildlife Service to determine applicable measures to reduce impacts to migratory birds or eagles, including whether “incidental take” permits are necessary and available under the Migratory Bird Treaty Act or Bald and Golden Eagle Protection Act for a particular activity.

20. Historic Properties. (a) In cases where the district engineer determines that the activity may have the potential to cause effects to properties listed, or eligible for listing, in the National Register of Historic Places, the activity is not authorized, until the requirements of Section 106 of the National Historic Preservation Act (NHPA) have been satisfied.

(b) Federal permittees should follow their own procedures for complying with the requirements of Section 106 of the National Historic Preservation Act. If pre-construction notification is required for the proposed NWP activity, the Federal permittee must provide the district engineer with the appropriate documentation to demonstrate compliance with those requirements. The district engineer will verify that the appropriate documentation has been submitted. If the appropriate documentation is not submitted, then additional consultation under Section 106 may be necessary. The respective federal agency is responsible for fulfilling its obligation to comply with Section 106.

(c) Non-federal permittees must submit a pre-construction notification to the district engineer if the NWP activity might have the potential to cause effects to any historic properties listed on, determined to be eligible for listing on, or potentially eligible for listing on the National Register of Historic Places, including previously unidentified properties. For such activities, the pre-construction notification must state which historic properties might have the potential to be affected by the proposed NWP activity or include a vicinity map indicating the location of the historic properties or the potential for the presence of historic properties. Assistance regarding information on the location of, or potential for, the presence of historic properties can be sought from the State Historic Preservation Officer, Tribal Historic Preservation Officer, or designated tribal representative, as appropriate, and the National Register of Historic Places (see 33 CFR 330.4(g)). When reviewing pre-construction notifications, district engineers will comply with the current procedures for addressing the requirements of Section 106 of the National Historic Preservation Act. The district engineer shall make a reasonable and good faith effort to carry out appropriate identification efforts, which may include background research, consultation, oral history interviews, sample field investigation, and field survey. Based on the information submitted in the PCN and these identification efforts, the district engineer shall determine whether the proposed NWP activity has the potential to cause effects on the historic properties. Section 106 consultation is not required when the district engineer determines that the activity does not have the potential to cause effects on historic properties (see 36 CFR 800.3(a)). Section 106 consultation is required when the district engineer determines that the activity has the potential to cause effects on historic properties. The district engineer will conduct consultation with consulting parties identified under 36 CFR 800.2(c) when he or she makes any of the following effect determinations for the purposes of Section 106 of the NHPA: no historic properties affected, no adverse effect, or adverse effect. Where the non-Federal applicant has identified historic properties on which the activity might have the potential to cause effects and so notified the

Corps, the non-Federal applicant shall not begin the activity until notified by the district engineer either that the activity has no potential to cause effects to historic properties or that NHPA Section 106 consultation has been completed.

(d) For non-federal permittees, the district engineer will notify the prospective permittee within 45 days of receipt of a complete pre-construction notification whether NHPA Section 106 consultation is required. If NHPA Section 106 consultation is required, the district engineer will notify the non-Federal applicant that he or she cannot begin the activity until Section 106 consultation is completed. If the non-Federal applicant has not heard back from the Corps within 45 days, the applicant must still wait for notification from the Corps.

(e) Prospective permittees should be aware that Section 110k of the NHPA (54 U.S.C. 306113) prevents the Corps from granting a permit or other assistance to an applicant who, with intent to avoid the requirements of Section 106 of the NHPA, has intentionally significantly adversely affected a historic property to which the permit would relate, or having legal power to prevent it, allowed such significant adverse effect to occur, unless the Corps, after consultation with the Advisory Council on Historic Preservation (ACHP), determines that circumstances justify granting such assistance despite the adverse effect created or permitted by the applicant. If circumstances justify granting the assistance, the Corps is required to notify the ACHP and provide documentation specifying the circumstances, the degree of damage to the integrity of any historic properties affected, and proposed mitigation. This documentation must include any views obtained from the applicant, SHPO/THPO, appropriate Indian tribes if the undertaking occurs on or affects historic properties on tribal lands or affects properties of interest to those tribes, and other parties known to have a legitimate interest in the impacts to the permitted activity on historic properties.

21. Discovery of Previously Unknown Remains and Artifacts. If you discover any previously unknown historic, cultural or archeological remains and artifacts while accomplishing the activity authorized by this permit, you must immediately notify the district engineer of what you have found, and to the maximum extent practicable, avoid construction activities that may affect the remains and artifacts until the required coordination has been completed. The district engineer will initiate the Federal, Tribal, and state coordination required to determine if the items or remains warrant a recovery effort or if the site is eligible for listing in the National Register of Historic Places.

22. Designated Critical Resource Waters. Critical resource waters include, NOAA-managed marine sanctuaries and marine monuments, and National Estuarine Research Reserves. The district engineer may designate, after notice and opportunity for public comment, additional waters officially designated by a state as having particular environmental or ecological significance, such as outstanding national resource waters or state natural heritage sites. The district engineer may also designate additional critical resource waters after notice and opportunity for public comment.

(a) Discharges of dredged or fill material into waters of the United States are not authorized by NWPs #7, 12, 14, 16, 17, 21, 29, 31, 35, 39, 40, 42, 43, 44, 49, 50, 51, and 52 for any activity within, or directly affecting, critical resource waters, including wetlands adjacent to such waters.

(b) For NWPs #3, 8, 10, 13, 15, 18, 19, 22, 23, 25, 27, 28, 30, 33, 34, 36, 37, 38, and 54, notification is required in accordance with General Condition #32, for any activity proposed in the designated critical resource waters including wetlands adjacent to those waters. The district engineer may authorize activities under these NWPs only after it is determined that the impacts to the critical resource waters will be no more than minimal.

23. Mitigation. The district engineer will consider the following factors when determining appropriate and practicable mitigation necessary to ensure that the individual and cumulative adverse environmental effects are no more than minimal:

(a) The activity must be designed and constructed to avoid and minimize adverse effects, both temporary and permanent, to waters of the United States to the maximum extent practicable at the project site (i.e., on site).

(b) Mitigation in all its forms (avoiding, minimizing, rectifying, reducing, or compensating for resource losses) will be required to the extent necessary to ensure that the individual and cumulative adverse environmental effects are no more than minimal.

(c) Compensatory mitigation at a minimum one-for-one ratio will be required for all wetland losses that exceed 1/10-acre and require pre-construction notification, unless the district engineer determines in writing that either some other form of mitigation would be more environmentally appropriate or the adverse environmental effects of the proposed activity are no more than minimal, and provides an activity-specific waiver of this requirement. For wetland losses of 1/10-acre or less that require pre-construction notification, the district engineer may determine on a case-by-case basis that compensatory mitigation is required to ensure that the activity results in only minimal adverse environmental effects.

(d) For losses of streams or other open waters that require pre-construction notification, the district engineer may require compensatory mitigation to ensure that the activity results in no more than minimal adverse environmental effects. Compensatory mitigation for losses of streams should be provided, if practicable, through stream rehabilitation, enhancement, or preservation, since streams are difficult-to-replace resources (see 33 CFR 332.3(e)(3)).

(e) Compensatory mitigation plans for NWP activities in or near streams or other open waters will normally include a requirement for the restoration or enhancement, maintenance, and legal protection (e.g., conservation easements) of riparian areas next to open waters. In some cases, the restoration or maintenance/protection of riparian areas may be the only compensatory mitigation required. Restored riparian areas should consist of native species. The width of the required riparian area will address documented water quality or aquatic habitat loss concerns. Normally, the riparian area will be 25 to 50 feet wide on each side of the stream, but the district engineer may require slightly wider riparian areas to address documented water quality or habitat loss concerns. If it is not possible to restore or maintain/protect a riparian area on both sides of a stream, or if the waterbody is a lake or coastal waters, then restoring or maintaining/protecting a riparian area along a single bank or shoreline may be sufficient. Where both wetlands and open waters exist on the project site, the district engineer will determine the appropriate compensatory mitigation (e.g., riparian areas and/or wetlands compensation) based on what is best for the aquatic environment on a watershed basis. In cases where riparian areas are determined to be the most appropriate form of minimization or compensatory mitigation, the district engineer may waive or reduce the requirement to provide wetland compensatory mitigation for wetland losses.

(f) Compensatory mitigation projects provided to offset losses of aquatic resources must comply with the applicable provisions of 33 CFR part 332.

(1) The prospective permittee is responsible for proposing an appropriate compensatory mitigation option if compensatory mitigation is necessary to ensure that the activity results in no more than minimal adverse environmental effects. For the NWPs, the preferred mechanism for providing compensatory mitigation is mitigation bank credits or in-lieu fee program credits (see 33 CFR 332.3(b)(2) and (3)). However, if an appropriate number and type of mitigation bank or in-lieu credits are not available at the time the PCN is submitted to the district engineer, the district engineer may approve the use of permittee-responsible mitigation.

(2) The amount of compensatory mitigation required by the district engineer must be sufficient to ensure that the authorized activity results in no more than minimal individual and cumulative adverse environmental effects (see 33 CFR 330.1(e)(3)). (See also 33 CFR 332.3(f)).

(3) Since the likelihood of success is greater and the impacts to potentially valuable uplands are reduced, aquatic resource restoration should be the first compensatory mitigation option considered for permittee-responsible mitigation.

(4) If permittee-responsible mitigation is the proposed option, the prospective permittee is responsible for submitting a mitigation plan. A conceptual or detailed mitigation plan may be used by the district engineer to make the decision on the NWP verification request, but a final mitigation plan that addresses the applicable requirements of 33 CFR 332.4(c)(2) through (14) must be approved by the district engineer before the permittee begins work in waters of the United States, unless the district engineer determines that prior approval of the final mitigation plan is not practicable or not necessary to ensure timely completion of the required compensatory mitigation (see 33 CFR 332.3(k)(3)).



(5) If mitigation bank or in-lieu fee program credits are the proposed option, the mitigation plan only needs to address the baseline conditions at the impact site and the number of credits to be provided.

(6) Compensatory mitigation requirements (e.g., resource type and amount to be provided as compensatory mitigation, site protection, ecological performance standards, monitoring requirements) may be addressed through conditions added to the NWP authorization, instead of components of a compensatory mitigation plan (see 33 CFR 332.4(c)(1)(ii)).

(g) Compensatory mitigation will not be used to increase the acreage losses allowed by the acreage limits of the NWPs. For example, if an NWP has an acreage limit of 1/2-acre, it cannot be used to authorize any NWP activity resulting in the loss of greater than 1/2-acre of waters of the United States, even if compensatory mitigation is provided that replaces or restores some of the lost waters. However, compensatory mitigation can and should be used, as necessary, to ensure that an NWP activity already meeting the established acreage limits also satisfies the no more than minimal impact requirement for the NWPs.

(h) Permittees may propose the use of mitigation banks, in-lieu fee programs, or permittee-responsible mitigation. When developing a compensatory mitigation proposal, the permittee must consider appropriate and practicable options consistent with the framework at 33 CFR 332.3(b). For activities resulting in the loss of marine or estuarine resources, permittee-responsible mitigation may be environmentally preferable if there are no mitigation banks or in-lieu fee programs in the area that have marine or estuarine credits available for sale or transfer to the permittee. For permittee-responsible mitigation, the special conditions of the NWP verification must clearly indicate the party or parties responsible for the implementation and performance of the compensatory mitigation project, and, if required, its long-term management.

(i) Where certain functions and services of waters of the United States are permanently adversely affected by a regulated activity, such as discharges of dredged or fill material into waters of the United States that will convert a forested or scrub-shrub wetland to a herbaceous wetland in a permanently maintained utility line right-of-way, mitigation may be required to reduce the adverse environmental effects of the activity to the no more than minimal level.

24. Safety of Impoundment Structures. To ensure that all impoundment structures are safely designed, the district engineer may require non-Federal applicants to demonstrate that the structures comply with established state dam safety criteria or have been designed by qualified persons. The district engineer may also require documentation that the design has been independently reviewed by similarly qualified persons, and appropriate modifications made to ensure safety.

25. Water Quality. Where States and authorized Tribes, or EPA where applicable, have not previously certified compliance of an NWP with CWA Section 401, individual 401 Water Quality Certification must be obtained or waived (see 33 CFR 330.4(c)). The district engineer or State or Tribe may require additional water quality management measures to ensure that the authorized activity does not result in more than minimal degradation of water quality.

26. Coastal Zone Management. In coastal states where an NWP has not previously received a state coastal zone management consistency concurrence, an individual state coastal zone management consistency concurrence must be obtained, or a presumption of concurrence must occur (see 33 CFR 330.4(d)). The district engineer or a State may require additional measures to ensure that the authorized activity is consistent with state coastal zone management requirements.

27. Regional and Case-By-Case Conditions. The activity must comply with any regional conditions that may have been added by the Division Engineer (see 33 CFR 330.4(e)) and with any case specific conditions added by the Corps or by the state, Indian Tribe, or U.S. EPA in its Section 401 Water Quality Certification, or by the state in its Coastal Zone Management Act consistency determination.

28. Use of Multiple Nationwide Permits. The use of more than one NWP for a single and complete project is prohibited, except when the acreage loss of waters of the United States authorized by the NWPs does not exceed the acreage limit of the NWP with the highest specified acreage limit. For example, if a road crossing over tidal

waters is constructed under NWP #14, with associated bank stabilization authorized by NWP #13, the maximum acreage loss of waters of the United States for the total project cannot exceed 1/3-acre.

29. Transfer of Nationwide Permit Verifications. If the permittee sells the property associated with a nationwide permit verification, the permittee may transfer the nationwide permit verification to the new owner by submitting a letter to the appropriate Corps district office to validate the transfer. A copy of the nationwide permit verification must be attached to the letter, and the letter must contain the following statement and signature:

“When the structures or work authorized by this nationwide permit are still in existence at the time the property is transferred, the terms and conditions of this nationwide permit, including any special conditions, will continue to be binding on the new owner(s) of the property. To validate the transfer of this nationwide permit and the associated liabilities associated with compliance with its terms and conditions, have the transferee sign and date below.”

\_\_\_\_\_  
(Transferee)

\_\_\_\_\_  
(Date)

30. Compliance Certification. Each permittee who receives an NWP verification letter from the Corps must provide a signed certification documenting completion of the authorized activity and implementation of any required compensatory mitigation. The success of any required permittee-responsible mitigation, including the achievement of ecological performance standards, will be addressed separately by the district engineer. The Corps will provide the permittee the certification document with the NWP verification letter. The certification document will include:

(a) A statement that the authorized activity was done in accordance with the NWP authorization, including any general, regional, or activity-specific conditions;

(b) A statement that the implementation of any required compensatory mitigation was completed in accordance with the permit conditions. If credits from a mitigation bank or in-lieu fee program are used to satisfy the compensatory mitigation requirements, the certification must include the documentation required by 33 CFR 332.3(1)(3) to confirm that the permittee secured the appropriate number and resource type of credits; and

(c) The signature of the permittee certifying the completion of the activity and mitigation.

The completed certification document must be submitted to the district engineer within 30 days of completion of the authorized activity or the implementation of any required compensatory mitigation, whichever occurs later.

31. Activities Affecting Structures or Works Built by the United States. If an NWP activity also requires permission from the Corps pursuant to 33 U.S.C. 408 because it will alter or temporarily or permanently occupy or use a U.S. Army Corps of Engineers (USACE) federally authorized Civil Works project (a “USACE project”), the prospective permittee must submit a pre-construction notification. See paragraph (b)(10) of General Condition #32. An activity that requires Section 408 permission is not authorized by NWP until the appropriate Corps office issues the Section 408 permission to alter, occupy, or use the USACE project, and the district engineer issues a written NWP verification.

32. Pre-Construction Notification. (a) Timing. Where required by the terms of the NWP, the prospective permittee must notify the district engineer by submitting a pre-construction notification (PCN) as early as possible. The district engineer must determine if the PCN is complete within 30 calendar days of the date of receipt and, if the PCN is determined to be incomplete, notify the prospective permittee within that 30 day period to request the additional information necessary to make the PCN complete. The request must specify the information needed to make the PCN complete. As a general rule, district engineers will request additional information necessary to make the PCN complete only once. However, if the prospective permittee does not provide all of the requested

information, then the district engineer will notify the prospective permittee that the PCN is still incomplete and the PCN review process will not commence until all of the requested information has been received by the district engineer. The prospective permittee shall not begin the activity until either:

(1) He or she is notified in writing by the district engineer that the activity may proceed under the NWP with any special conditions imposed by the district or division engineer; or

(2) 45 calendar days have passed from the district engineer's receipt of the complete PCN and the prospective permittee has not received written notice from the district or division engineer. However, if the permittee was required to notify the Corps pursuant to General Condition #18 that listed species or critical habitat might be affected or are in the vicinity of the activity, or to notify the Corps pursuant to General Condition #20 that the activity might have the potential to cause effects to historic properties, the permittee cannot begin the activity until receiving written notification from the Corps that there is "no effect" on listed species or "no potential to cause effects" on historic properties, or that any consultation required under Section 7 of the Endangered Species Act (see 33 CFR 330.4(f)) and/or Section 106 of the National Historic Preservation Act (see 33 CFR 330.4(g)) has been completed. Also, work cannot begin under NWPs #21, 49, or 50 until the permittee has received written approval from the Corps. If the proposed activity requires a written waiver to exceed specified limits of an NWP, the permittee may not begin the activity until the district engineer issues the waiver. If the district or division engineer notifies the permittee in writing that an individual permit is required within 45 calendar days of receipt of a complete PCN, the permittee cannot begin the activity until an individual permit has been obtained. Subsequently, the permittee's right to proceed under the NWP may be modified, suspended, or revoked only in accordance with the procedure set forth in 33 CFR 330.5(d)(2).

(b) Contents of Pre-Construction Notification: The PCN must be in writing and include the following information:

(1) Name, address and telephone numbers of the prospective permittee;

(2) Location of the proposed activity;

(3) Identify the specific NWP or NWP(s) the prospective permittee wants to use to authorize the proposed activity;

(4) A description of the proposed activity; the activity's purpose; direct and indirect adverse environmental effects the activity would cause, including the anticipated amount of loss of wetlands, other special aquatic sites, and other waters expected to result from the NWP activity, in acres, linear feet, or other appropriate unit of measure; a description of any proposed mitigation measures intended to reduce the adverse environmental effects caused by the proposed activity; and any other NWP(s), regional general permit(s), or individual permit(s) used or intended to be used to authorize any part of the proposed project or any related activity, including other separate and distant crossings for linear projects that require Department of the Army authorization but do not require pre-construction notification. The description of the proposed activity and any proposed mitigation measures should be sufficiently detailed to allow the district engineer to determine that the adverse environmental effects of the activity will be no more than minimal and to determine the need for compensatory mitigation or other mitigation measures. For single and complete linear projects, the PCN must include the quantity of anticipated losses of wetlands, other special aquatic sites, and other waters for each single and complete crossing of those wetlands, other special aquatic sites, and other waters. Sketches should be provided when necessary to show that the activity complies with the terms of the NWP. (Sketches usually clarify the activity and when provided results in a quicker decision. Sketches should contain sufficient detail to provide an illustrative description of the proposed activity (e.g., a conceptual plan), but do not need to be detailed engineering plans);

(5) The PCN must include a delineation of wetlands, other special aquatic sites, and other waters, such as lakes and ponds, and perennial, intermittent, and ephemeral streams, on the project site. Wetland delineations must be prepared in accordance with the current method required by the Corps. The permittee may ask the Corps to delineate the special aquatic sites and other waters on the project site, but there may be a delay if the Corps does the delineation, especially if the project site is large or contains many wetlands, other special aquatic sites, and other

waters. Furthermore, the 45 day period will not start until the delineation has been submitted to or completed by the Corps, as appropriate;

(6) If the proposed activity will result in the loss of greater than 1/10-acre of wetlands and a PCN is required, the prospective permittee must submit a statement describing how the mitigation requirement will be satisfied, or explaining why the adverse environmental effects are no more than minimal and why compensatory mitigation should not be required. As an alternative, the prospective permittee may submit a conceptual or detailed mitigation plan.

(7) For non-Federal permittees, if any listed species or designated critical habitat might be affected or is in the vicinity of the activity, or if the activity is located in designated critical habitat, the PCN must include the name(s) of those endangered or threatened species that might be affected by the proposed activity or utilize the designated critical habitat that might be affected by the proposed activity. For NWP activities that require pre-construction notification, Federal permittees must provide documentation demonstrating compliance with the Endangered Species Act;

(8) For non-Federal permittees, if the NWP activity might have the potential to cause effects to a historic property listed on, determined to be eligible for listing on, or potentially eligible for listing on, the National Register of Historic Places, the PCN must state which historic property might have the potential to be affected by the proposed activity or include a vicinity map indicating the location of the historic property. For NWP activities that require pre-construction notification, Federal permittees must provide documentation demonstrating compliance with Section 106 of the National Historic Preservation Act;

(9) For an activity that will occur in a component of the National Wild and Scenic River System, or in a river officially designated by Congress as a “study river” for possible inclusion in the system while the river is in an official study status, the PCN must identify the Wild and Scenic River or the “study river” (see General Condition #16); and

(10) For an activity that requires permission from the Corps pursuant to 33 U.S.C. 408 because it will alter or temporarily or permanently occupy or use a U.S. Army Corps of Engineers federally authorized civil works project, the pre-construction notification must include a statement confirming that the project proponent has submitted a written request for Section 408 permission from the Corps office having jurisdiction over that USACE project.

(c) Form of Pre-Construction Notification: The standard individual permit application form (Form ENG 4345) may be used, but the completed application form must clearly indicate that it is an NWP PCN and must include all of the applicable information required in paragraphs (b)(1) through (10) of this General Condition. A letter containing the required information may also be used. Applicants may provide electronic files of PCNs and supporting materials if the district engineer has established tools and procedures for electronic submittals.

(d) Agency Coordination: (1) The district engineer will consider any comments from Federal and state agencies concerning the proposed activity’s compliance with the terms and conditions of the NWPs and the need for mitigation to reduce the activity’s adverse environmental effects so that they are no more than minimal.

(2) Agency coordination is required for: (i) all NWP activities that require pre-construction notification and result in the loss of greater than 1/2-acre of waters of the United States; (ii) NWPs #21, 29, 39, 40, 42, 43, 44, 50, 51, and 52 activities that require pre-construction notification and will result in the loss of greater than 300 linear feet of stream bed; (iii) NWP 13 activities in excess of 500 linear feet, fills greater than one cubic yard per running foot, or involve discharges of dredged or fill material into special aquatic sites; and (iv) NWP #54 activities in excess of 500 linear feet, or that extend into the waterbody more than 30 feet from the mean low water line in tidal waters or the ordinary high water mark in the Great Lakes.

(3) When agency coordination is required, the district engineer will immediately provide (e.g., via e-mail, facsimile transmission, overnight mail, or other expeditious manner) a copy of the complete PCN to the appropriate Federal or state offices (FWS, state natural resource or water quality agency, EPA, and, if appropriate, the NMFS). With the exception of NWP #37, these agencies will have 10 calendar days from the date the material is transmitted to

notify the district engineer via telephone, facsimile transmission, or e-mail that they intend to provide substantive, site-specific comments. The comments must explain why the agency believes the adverse environmental effects will be more than minimal. If so contacted by an agency, the district engineer will wait an additional 15 calendar days before making a decision on the pre-construction notification. The district engineer will fully consider agency comments received within the specified time frame concerning the proposed activity's compliance with the terms and conditions of the NWP, including the need for mitigation to ensure the net adverse environmental effects of the proposed activity are no more than minimal. The district engineer will provide no response to the resource agency, except as provided below. The district engineer will indicate in the administrative record associated with each pre-construction notification that the resource agencies' concerns were considered. For NWP #37, the emergency watershed protection and rehabilitation activity may proceed immediately in cases where there is an unacceptable hazard to life or a significant loss of property or economic hardship will occur. The district engineer will consider any comments received to decide whether the NWP #37 authorization should be modified, suspended, or revoked in accordance with the procedures at 33 CFR 330.5.

(4) In cases of where the prospective permittee is not a Federal agency, the district engineer will provide a response to NMFS within 30 calendar days of receipt of any Essential Fish Habitat conservation recommendations, as required by Section 305(b)(4)(B) of the Magnuson-Stevens Fishery Conservation and Management Act.

(5) Applicants are encouraged to provide the Corps with either electronic files or multiple copies of pre-construction notifications to expedite agency coordination.

#### D. District Engineer's Decision

1. In reviewing the PCN for the proposed activity, the district engineer will determine whether the activity authorized by the NWP will result in more than minimal individual or cumulative adverse environmental effects or may be contrary to the public interest. If a project proponent requests authorization by a specific NWP, the district engineer should issue the NWP verification for that activity if it meets the terms and conditions of that NWP, unless he or she determines, after considering mitigation, that the proposed activity will result in more than minimal individual and cumulative adverse effects on the aquatic environment and other aspects of the public interest and exercises discretionary authority to require an individual permit for the proposed activity. For a linear project, this determination will include an evaluation of the individual crossings of waters of the United States to determine whether they individually satisfy the terms and conditions of the NWP(s), as well as the cumulative effects caused by all of the crossings authorized by NWP. If an applicant requests a waiver of the 300 linear foot limit on impacts to streams or of an otherwise applicable limit, as provided for in NWPs #13, 21, 29, 36, 39, 40, 42, 43, 44, 50, 51, 52, or 54, the district engineer will only grant the waiver upon a written determination that the NWP activity will result in only minimal individual and cumulative adverse environmental effects. For those NWPs that have a waivable 300 linear foot limit for losses of intermittent and ephemeral stream bed and a 1/2-acre limit (i.e., NWPs #21, 29, 39, 40, 42, 43, 44, 50, 51, and 52), the loss of intermittent and ephemeral stream bed, plus any other losses of jurisdictional waters and wetlands, cannot exceed 1/2-acre.

2. When making minimal adverse environmental effects determinations the district engineer will consider the direct and indirect effects caused by the NWP activity. He or she will also consider the cumulative adverse environmental effects caused by activities authorized by NWP and whether those cumulative adverse environmental effects are no more than minimal. The district engineer will also consider site specific factors, such as the environmental setting in the vicinity of the NWP activity, the type of resource that will be affected by the NWP activity, the functions provided by the aquatic resources that will be affected by the NWP activity, the degree or magnitude to which the aquatic resources perform those functions, the extent that aquatic resource functions will be lost as a result of the NWP activity (e.g., partial or complete loss), the duration of the adverse effects (temporary or permanent), the importance of the aquatic resource functions to the region (e.g., watershed or ecoregion), and mitigation required by the district engineer. If an appropriate functional or condition assessment method is available and practicable to use, that assessment method may be used by the district engineer to assist in the minimal adverse environmental effects determination. The district engineer may add case-specific special conditions to the NWP authorization to address site-specific environmental concerns.

3. If the proposed activity requires a PCN and will result in a loss of greater than 1/10-acre of wetlands, the prospective permittee should submit a mitigation proposal with the PCN. Applicants may also propose compensatory mitigation for NWP activities with smaller impacts, or for impacts to other types of waters (e.g.,

streams). The district engineer will consider any proposed compensatory mitigation or other mitigation measures the applicant has included in the proposal in determining whether the net adverse environmental effects of the proposed activity are no more than minimal. The compensatory mitigation proposal may be either conceptual or detailed. If the district engineer determines that the activity complies with the terms and conditions of the NWP and that the adverse environmental effects are no more than minimal, after considering mitigation, the district engineer will notify the permittee and include any activity-specific conditions in the NWP verification the district engineer deems necessary. Conditions for compensatory mitigation requirements must comply with the appropriate provisions at 33 CFR 332.3(k). The district engineer must approve the final mitigation plan before the permittee commences work in waters of the United States, unless the district engineer determines that prior approval of the final mitigation plan is not practicable or not necessary to ensure timely completion of the required compensatory mitigation. If the prospective permittee elects to submit a compensatory mitigation plan with the PCN, the district engineer will expeditiously review the proposed compensatory mitigation plan. The district engineer must review the proposed compensatory mitigation plan within 45 calendar days of receiving a complete PCN and determine whether the proposed mitigation would ensure the NWP activity results in no more than minimal adverse environmental effects. If the net adverse environmental effects of the NWP activity (after consideration of the mitigation proposal) are determined by the district engineer to be no more than minimal, the district engineer will provide a timely written response to the applicant. The response will state that the NWP activity can proceed under the terms and conditions of the NWP, including any activity-specific conditions added to the NWP authorization by the district engineer.

4. If the district engineer determines that the adverse environmental effects of the proposed activity are more than minimal, then the district engineer will notify the applicant either: (a) that the activity does not qualify for authorization under the NWP and instruct the applicant on the procedures to seek authorization under an individual permit; (b) that the activity is authorized under the NWP subject to the applicant's submission of a mitigation plan that would reduce the adverse environmental effects so that they are no more than minimal; or (c) that the activity is authorized under the NWP with specific modifications or conditions. Where the district engineer determines that mitigation is required to ensure no more than minimal adverse environmental effects, the activity will be authorized within the 45-day PCN period (unless additional time is required to comply with General Conditions #18, 20, and/or 31, or to evaluate PCNs for activities authorized by NWPs #21, 49, and 50), with activity-specific conditions that state the mitigation requirements. The authorization will include the necessary conceptual or detailed mitigation plan or a requirement that the applicant submit a mitigation plan that would reduce the adverse environmental effects so that they are no more than minimal. When compensatory mitigation is required, no work in waters of the United States may occur until the district engineer has approved a specific mitigation plan or has determined that prior approval of a final mitigation plan is not practicable or not necessary to ensure timely completion of the required compensatory mitigation.

#### E. Further Information

1. District Engineers have authority to determine if an activity complies with the terms and conditions of an NWP.

2. NWPs do not obviate the need to obtain other federal, state, or local permits, approvals, or authorizations required by law.

3. NWPs do not grant any property rights or exclusive privileges.

4. NWPs do not authorize any injury to the property or rights of others.

5. NWPs do not authorize interference with any existing or proposed Federal project (see General Condition #31).

#### F. Definitions

Best management practices (BMPs): Policies, practices, procedures, or structures implemented to mitigate the adverse environmental effects on surface water quality resulting from development. BMPs are categorized as structural or non-structural.

Compensatory mitigation: The restoration (re-establishment or rehabilitation), establishment (creation), enhancement, and/or in certain circumstances preservation of aquatic resources for the purposes of offsetting unavoidable adverse impacts which remain after all appropriate and practicable avoidance and minimization has been achieved.

Currently serviceable: Useable as is or with some maintenance, but not so degraded as to essentially require reconstruction.

Direct effects: Effects that are caused by the activity and occur at the same time and place.

Discharge: The term “discharge” means any discharge of dredged or fill material into waters of the United States.

Ecological reference: A model used to plan and design an aquatic habitat and riparian area restoration, enhancement, or establishment activity under NWP #27. An ecological reference may be based on the structure, functions, and dynamics of an aquatic habitat type or a riparian area type that currently exists in the region where the proposed NWP #27 activity is located. Alternatively, an ecological reference may be based on a conceptual model for the aquatic habitat type or riparian area type to be restored, enhanced, or established as a result of the proposed NWP #27 activity. An ecological reference takes into account the range of variation of the aquatic habitat type or riparian area type in the region.

Enhancement: The manipulation of the physical, chemical, or biological characteristics of an aquatic resource to heighten, intensify, or improve a specific aquatic resource function(s). Enhancement results in the gain of selected aquatic resource function(s), but may also lead to a decline in other aquatic resource function(s). Enhancement does not result in a gain in aquatic resource area.

Ephemeral stream: An ephemeral stream has flowing water only during, and for a short duration after, precipitation events in a typical year. Ephemeral stream beds are located above the water table year-round. Groundwater is not a source of water for the stream. Runoff from rainfall is the primary source of water for stream flow.

Establishment (creation): The manipulation of the physical, chemical, or biological characteristics present to develop an aquatic resource that did not previously exist at an upland site. Establishment results in a gain in aquatic resource area.

High Tide Line: The line of intersection of the land with the water’s surface at the maximum height reached by a rising tide. The high tide line may be determined, in the absence of actual data, by a line of oil or scum along shore objects, a more or less continuous deposit of fine shell or debris on the foreshore or berm, other physical markings or characteristics, vegetation lines, tidal gages, or other suitable means that delineate the general height reached by a rising tide. The line encompasses spring high tides and other high tides that occur with periodic frequency but does not include storm surges in which there is a departure from the normal or predicted reach of the tide due to the piling up of water against a coast by strong winds such as those accompanying a hurricane or other intense storm.

Historic Property: Any prehistoric or historic district, site (including archaeological site), building, structure, or other object included in, or eligible for inclusion in, the National Register of Historic Places maintained by the Secretary of the Interior. This term includes artifacts, records, and remains that are related to and located within such properties. The term includes properties of traditional religious and cultural importance to an Indian tribe or Native Hawaiian organization and that meet the National Register criteria (36 CFR part 60).

Independent utility: A test to determine what constitutes a single and complete non-linear project in the Corps Regulatory Program. A project is considered to have independent utility if it would be constructed absent the construction of other projects in the project area. Portions of a multi-phase project that depend upon other phases of the project do not have independent utility. Phases of a project that would be constructed even if the other phases were not built can be considered as separate single and complete projects with independent utility.

Indirect effects: Effects that are caused by the activity and are later in time or farther removed in distance, but are still reasonably foreseeable.

Intermittent stream: An intermittent stream has flowing water during certain times of the year, when groundwater provides water for stream flow. During dry periods, intermittent streams may not have flowing water. Runoff from rainfall is a supplemental source of water for stream flow.

Loss of waters of the United States: Waters of the United States that are permanently adversely affected by filling, flooding, excavation, or drainage because of the regulated activity. Permanent adverse effects include permanent discharges of dredged or fill material that change an aquatic area to dry land, increase the bottom elevation of a waterbody, or change the use of a waterbody. The acreage of loss of waters of the United States is a threshold measurement of the impact to jurisdictional waters for determining whether a project may qualify for an NWP; it is not a net threshold that is calculated after considering compensatory mitigation that may be used to offset losses of aquatic functions and services. The loss of stream bed includes the acres or linear feet of stream bed that are filled or excavated as a result of the regulated activity. Waters of the United States temporarily filled, flooded, excavated, or drained, but restored to pre-construction contours and elevations after construction, are not included in the measurement of loss of waters of the United States. Impacts resulting from activities that do not require Department of the Army authorization, such as activities eligible for exemptions under Section 404(f) of the Clean Water Act, are not considered when calculating the loss of waters of the United States.

Navigable waters: Waters subject to Section 10 of the Rivers and Harbors Act of 1899. These waters are defined at 33 CFR part 329.

Non-tidal wetland: A non-tidal wetland is a wetland that is not subject to the ebb and flow of tidal waters. Non-tidal wetlands contiguous to tidal waters are located landward of the high tide line (i.e., spring high tide line).

Open water: For purposes of the NWPs, an open water is any area that in a year with normal patterns of precipitation has water flowing or standing above ground to the extent that an ordinary high water mark can be determined. Aquatic vegetation within the area of flowing or standing water is either non-emergent, sparse, or absent. Vegetated shallows are considered to be open waters. Examples of “open waters” include rivers, streams, lakes, and ponds.

Ordinary High Water Mark: An ordinary high water mark is a line on the shore established by the fluctuations of water and indicated by physical characteristics, or by other appropriate means that consider the characteristics of the surrounding areas.

Perennial stream: A perennial stream has flowing water year-round during a typical year. The water table is located above the stream bed for most of the year. Groundwater is the primary source of water for stream flow. Runoff from rainfall is a supplemental source of water for stream flow.

Practicable: Available and capable of being done after taking into consideration cost, existing technology, and logistics in light of overall project purposes.

Pre-construction notification: A request submitted by the project proponent to the Corps for confirmation that a particular activity is authorized by nationwide permit. The request may be a permit application, letter, or similar document that includes information about the proposed work and its anticipated environmental effects. Pre-construction notification may be required by the terms and conditions of a nationwide permit, or by regional conditions. A pre-construction notification may be voluntarily submitted in cases where pre-construction notification is not required and the project proponent wants confirmation that the activity is authorized by nationwide permit.

Preservation: The removal of a threat to, or preventing the decline of, aquatic resources by an action in or near those aquatic resources. This term includes activities commonly associated with the protection and maintenance of aquatic resources through the implementation of appropriate legal and physical mechanisms. Preservation does not result in a gain of aquatic resource area or functions.



Protected tribal resources: Those natural resources and properties of traditional or customary religious or cultural importance, either on or off Indian lands, retained by, or reserved by or for, Indian tribes through treaties, statutes, judicial decisions, or executive orders, including tribal trust resources.

Re-establishment: The manipulation of the physical, chemical, or biological characteristics of a site with the goal of returning natural/historic functions to a former aquatic resource. Re-establishment results in rebuilding a former aquatic resource and results in a gain in aquatic resource area and functions.

Rehabilitation: The manipulation of the physical, chemical, or biological characteristics of a site with the goal of repairing natural/historic functions to a degraded aquatic resource. Rehabilitation results in a gain in aquatic resource function, but does not result in a gain in aquatic resource area.

Restoration: The manipulation of the physical, chemical, or biological characteristics of a site with the goal of returning natural/historic functions to a former or degraded aquatic resource. For the purpose of tracking net gains in aquatic resource area, restoration is divided into two categories: re-establishment and rehabilitation.

Riffle and pool complex: Riffle and pool complexes are special aquatic sites under the 404(b)(1) Guidelines. Riffle and pool complexes sometimes characterize steep gradient sections of streams. Such stream sections are recognizable by their hydraulic characteristics. The rapid movement of water over a coarse substrate in riffles results in a rough flow, a turbulent surface, and high dissolved oxygen levels in the water. Pools are deeper areas associated with riffles. A slower stream velocity, a streaming flow, a smooth surface, and a finer substrate characterize pools.

Riparian areas: Riparian areas are lands next to streams, lakes, and estuarine-marine shorelines. Riparian areas are transitional between terrestrial and aquatic ecosystems, through which surface and subsurface hydrology connects riverine, lacustrine, estuarine, and marine waters with their adjacent wetlands, non-wetland waters, or uplands. Riparian areas provide a variety of ecological functions and services and help improve or maintain local water quality. (See General Condition #23.)

Shellfish seeding: The placement of shellfish seed and/or suitable substrate to increase shellfish production. Shellfish seed consists of immature individual shellfish or individual shellfish attached to shells or shell fragments (i.e., spat on shell). Suitable substrate may consist of shellfish shells, shell fragments, or other appropriate materials placed into waters for shellfish habitat.

Single and complete linear project: A linear project is a project constructed for the purpose of getting people, goods, or services from a point of origin to a terminal point, which often involves multiple crossings of one or more waterbodies at separate and distant locations. The term “single and complete project” is defined as that portion of the total linear project proposed or accomplished by one owner/developer or partnership or other association of owners/developers that includes all crossings of a single water of the United States (i.e., a single waterbody) at a specific location. For linear projects crossing a single or multiple waterbodies several times at separate and distant locations, each crossing is considered a single and complete project for purposes of NWP authorization. However, individual channels in a braided stream or river, or individual arms of a large, irregularly shaped wetland or lake, etc., are not separate waterbodies, and crossings of such features cannot be considered separately.

Single and complete non-linear project: For non-linear projects, the term “single and complete project” is defined at 33 CFR 330.2(i) as the total project proposed or accomplished by one owner/developer or partnership or other association of owners/developers. A single and complete non-linear project must have independent utility (see definition of “independent utility”). Single and complete non-linear projects may not be “piecemealed” to avoid the limits in an NWP authorization.

Stormwater management: Stormwater management is the mechanism for controlling stormwater runoff for the purposes of reducing downstream erosion, water quality degradation, and flooding and mitigating the adverse effects of changes in land use on the aquatic environment.

**Stormwater management facilities:** Stormwater management facilities are those facilities, including but not limited to, stormwater retention and detention ponds and best management practices, which retain water for a period of time to control runoff and/or improve the quality (i.e., by reducing the concentration of nutrients, sediments, hazardous substances and other pollutants) of stormwater runoff.

**Stream bed:** The substrate of the stream channel between the ordinary high water marks. The substrate may be bedrock or inorganic particles that range in size from clay to boulders. Wetlands contiguous to the stream bed, but outside of the ordinary high water marks, are not considered part of the stream bed.

**Stream channelization:** The manipulation of a stream's course, condition, capacity, or location that causes more than minimal interruption of normal stream processes. A channelized stream remains a water of the United States.

**Structure:** An object that is arranged in a definite pattern of organization. Examples of structures include, without limitation, any pier, boat dock, boat ramp, wharf, dolphin, weir, boom, breakwater, bulkhead, revetment, riprap, jetty, artificial island, artificial reef, permanent mooring structure, power transmission line, permanently moored floating vessel, piling, aid to navigation, or any other manmade obstacle or obstruction.

**Tidal wetland:** A tidal wetland is a jurisdictional wetland that is inundated by tidal waters. Tidal waters rise and fall in a predictable and measurable rhythm or cycle due to the gravitational pulls of the moon and sun. Tidal waters end where the rise and fall of the water surface can no longer be practically measured in a predictable rhythm due to masking by other waters, wind, or other effects. Tidal wetlands are located channelward of the high tide line.

**Tribal lands:** Any lands title to which is either: 1) held in trust by the United States for the benefit of any Indian tribe or individual; or 2) held by any Indian tribe or individual subject to restrictions by the United States against alienation.

**Tribal rights:** Those rights legally accruing to a tribe or tribes by virtue of inherent sovereign authority, unextinguished aboriginal title, treaty, statute, judicial decisions, executive order or agreement, and that give rise to legally enforceable remedies.

**Vegetated shallows:** Vegetated shallows are special aquatic sites under the 404(b)(1) Guidelines. They are areas that are permanently inundated and under normal circumstances have rooted aquatic vegetation, such as seagrasses in marine and estuarine systems and a variety of vascular rooted plants in freshwater systems.

**Waterbody:** For purposes of the NWP's, a waterbody is a jurisdictional water of the United States. If a wetland is adjacent to a waterbody determined to be a water of the United States, that waterbody and any adjacent wetlands are considered together as a single aquatic unit (see 33 CFR 328.4(c)(2)). Examples of "waterbodies" include streams, rivers, lakes, ponds, and wetlands.

## **G. Buffalo and New York District General Regional Conditions** **These conditions apply to ALL Nationwide Permits.**

**G-A. Construction Best Management Practices (BMP's):** Unless specifically approved otherwise through issuance of a variance by the District Engineer, the following BMP's must be implemented to the maximum degree practicable, to minimize erosion, migration of sediments, and adverse environmental impacts. Note that at a minimum, all erosion and sediment control and stormwater management practices must be designed, installed and maintained throughout the entire construction project in accordance with the latest version of the "*New York Standards and Specifications for Erosion and Sediment Control*" and the "*New York State Stormwater Management Design Manual*". These documents are available at: <http://www.dec.ny.gov/chemical/29066.html> and <http://www.dec.ny.gov/chemical/29072.html>, respectively. Prior to the discharge of any dredged or fill material into waters of the United States, including wetlands, authorized by NWP, the permittee must install and maintain erosion and sedimentation controls in and/or adjacent to wetlands or other waters of the United States.

1. All synthetic erosion control features (e.g., silt fencing, netting, mats), which are intended for temporary use during construction, shall be completely removed and properly disposed of after their initial purpose has been served. Only natural fiber materials, which will degrade over time, may be abandoned in place.

2. Materials resulting from trench excavation for utility line installation or ditch reshaping activities which are temporarily sidecast or stockpiled into waters of the United States must be backfilled or removed to an upland area within 30 days of the date of deposition. Note: upland options shall be utilized prior to temporary placement within waters of the United States, unless it can be demonstrated that it would not be practicable or if the impacts of complying with this upland option requirement would result in more adverse impacts to the aquatic environment.
3. For trenching activities in wetlands the applicant shall install impermeable trench dams or trench breakers at the wetland boundaries and every 100 feet within wetland areas to prevent inadvertent drainage of wetlands or other waters of the United States.
4. Dry stream crossing methods (e.g., diversion, dam and pump, flume, bore) shall be utilized for culvert or other pipe, or utility installations to reduce downstream impacts from turbidity and sedimentation. This may require piping or pumping the stream flow around the work area and the use of cofferdams.
5. No in-stream work shall occur during periods of high flow, except for work that occurs in dewatered areas behind temporary diversions, cofferdams or causeways.
6. Construction access and staging areas shall be by means that avoid or minimize impacts to aquatic sites (e.g. use of upland areas for access & staging, floating barges, mats, etc.). Discharges of fill material associated with the construction of temporary access roads, staging areas and work pads in wetlands shall be placed on filter fabric. All temporary fills shall be removed upon completion of the work and the disturbed area restored to pre-construction contours, elevations and wetland conditions, including cover type. All vegetation utilized in the restoration activity shall consist of native species.
7. All return flow from dredged material disposal areas shall not result in an increase in turbidity in the receiving water body that will cause a substantial visible contrast to natural conditions. (See NWP #16)
8. For activities involving the placement of concrete into waters of the United States, the permittee must employ watertight forms. The forms shall be dewatered prior to the placement of the concrete. The use of tremie concrete is allowed, provided that it complies with New York State water quality standards.
9. New stormwater management facilities shall be located outside of waters of the United States. A variance of this requirement may be requested with the submission of a PCN. The PCN must include justification which demonstrates that avoidance and minimization efforts have been met.
10. To the maximum extent practicable, the placement of fill in wetlands must be designed to maintain pre-construction surface water flows/conditions between remaining on or off-site waters and to prevent draining of the wetland or permanent hydrologic alteration. This may require the use of culverts and/or other measures. Furthermore, the activity must not restrict or impede the passage of normal or expected high flows (unless the primary purpose of the fill is to impound waters). The activity may alter the pre-construction flows/conditions if it can be shown that it benefits the aquatic environment (i.e. wetland restoration and/or enhancement).

## **G-B. CULVERTS**

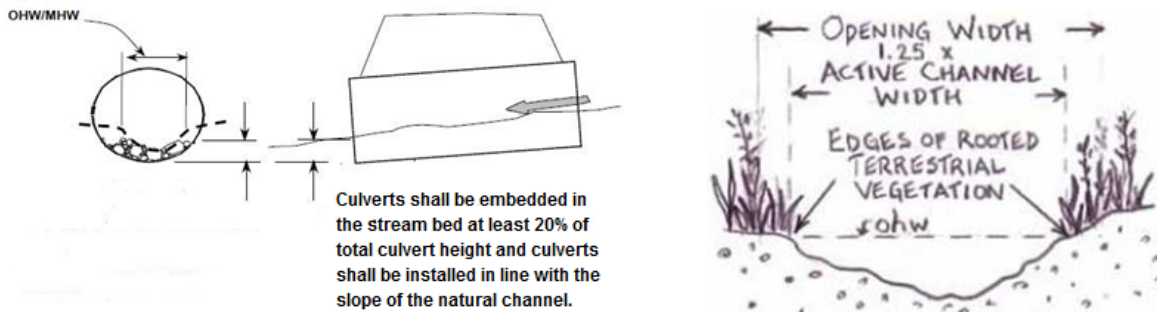
1. **ALL NEW OR REPLACEMENT CULVERTS** in streams shall be constructed/installed in accordance with the following, in order to ensure compliance with NWP General Condition #2 – Aquatic Life Movement and #9 Management of Water Flows:

- a. Size: Bank-full flows shall be accommodated through maintenance of the existing bank-full channel cross sectional dimensions within one culvert. Bank-full width is generally considered to be the top width at the stage where a stream begins to overtop its banks and spread into the floodplain. Either a bottomless culvert or bridge must be used where practicable. If the stream cannot be spanned, the culvert width shall be minimum of 1.25 times width of the stream channel at the ordinary high water, or a 2 year design storm.

- b. Depth: To maintain low flow and aquatic life movement within culverts with a bottom, the culvert invert must be embedded. Specifically, the culvert must be installed with its bottom buried below the grade of the stream bed, as measured at the average low point, to a depth of a minimum of 20 percent of the culvert vertical rise (height) throughout the length of the culvert. (Note: When not practicable to do so due to small culvert size, it is acceptable to allow natural deposition to cover the interior of the culvert bed following placement of the culvert invert to the 20% depth.)
- c. The dimension, pattern, and profile of the stream above and below the stream crossing shall not be permanently modified by changing the width or depth of the stream channel.
- d. The culvert bed slope shall remain consistent with the slope of the adjacent stream channel.
- e. Stone aprons and scour protection placed in streams shall not extend higher than the stream bed in order to create a uniform grade and shall be filled with native stream bed material and supplemented with similarly sized material, if needed, to fill interstitial spaces to maintain water flow on the surface of the stream bed.

**Note 1:** Use of the requirements alone will not satisfy the need for proper engineering and design. In particular, appropriate engineering is required to ensure structures are sized and designed to provide adequate capacity (to pass various flood flows) and stability (bed, bed forms, footings and abutments, both upstream and downstream). It is the permittee's responsibility to ensure the structure is appropriately designed.

The diameter of the culvert shall accommodate bankfull flows by sizing the culvert 1.25 times the stream width at ordinary high water/mean high water (OHW/MHW) mark, or a 2-year design storm.



**Note 2:** This condition does not apply to temporary culverts used for construction access that are in place for less than one construction season. However, compliance with General Conditions #2 and #9 still applies.

**Preconstruction Notification (PCN) Requirements:**

A PCN is required for projects that do not meet all of the above requirements. In addition to the PCN requirements of General Condition #32, the PCN must include the following information:

- i. A statement indicating which of the above requirements will not be met by the proposed project;
- ii. Information as to why the use of such structures or measures would not be practicable;
- iii. A brief description of the stream discussing:
  - Site specific information (i.e. stream bed slope, type and size of stream bed material, stream type, existing natural or manmade barriers, etc.) assessed to determine appropriate culvert design and to ensure management of water flows and aquatic life movement.
  - Evaluation of the replacement for its impacts on: downstream flooding, upstream and downstream habitat (in-stream habitat, wetlands), potential for erosion and headcutting, and stream stability.

- Flow/storm event the proposed culvert is designed to pass (2 year, 50 year, etc.)
- iv. Cross sections of the stream used to calculate the stream bed low point and ordinary high water width, consisting of:
- Stream channel cross sections shall be taken at proximal locations to the crossing location to determine the average of the lowest points in elevation of the stream bed and the average width at ordinary high water.
    - For new crossing locations, the average values from at least three measurements (project location and straight sections of the stream upstream and downstream) shall be used.
    - For replacement of an existing structure, the average values from at least two cross sections (straight sections of the stream upstream and downstream from the existing structure representative of the natural channel) shall be used.
  - This average low point shall be used to ensure low flow is maintained through the culvert and from which all embedment depths are measured.
  - If the above cross section method was not practicable to use, an alternative method may be utilized. The PCN shall include justification for the method used including the data used and an explanation as to how it provides an equivalent measure.
- v. An evaluation of the effects the crossing would have on aquatic life movement and/or water flows; and
- vi. Mitigation measures that will be employed to minimize these effects. Mitigation measures may include, but are not limited to baffles, weirs, roughened channels, and grade control structures

A variance of the requirement(s) will be issued by the Corps if it can be demonstrated that the proposal would meet General Conditions #2 and #9 and would result in the least environmentally damaging practicable alternative (e.g. compliance with any of the requirement(s) would result in detrimental impacts to the aquatic system).

**2. ALL CULVERT REHABILITATION PROJECTS** in streams, not including culvert replacement projects, shall be constructed in accordance with the following, in order to ensure compliance with NWP General Condition #2 – Aquatic Life Movement and #9 Management of Water Flows:

- a. An evaluation of the existing culvert shall be conducted prior to the proposed culvert rehabilitation to determine if the existing culvert is in compliance with NWP General Conditions #2 and #9. Specifically, the culvert shall be evaluated regarding its effect upon aquatic life movements and low/ high water flow. If the above requirements in General Regional Condition B. 1 (a)-(e) are met then the culvert is considered in compliance with NWP General Conditions #2 and #9. (Potential evaluation methods to consider include: North Atlantic Aquatic Connectivity Collaborative (NAACC), US Forest Service Aquatic Organism Passage Fish Xing, etc.)
- b. A PCN is not required for projects that utilize cured-in-place pipe lining or other repair activities that do not raise the existing invert elevation such that it causes an impediment to the passage of either aquatic life movement or water flow unless there is an existing impediment.
- c. A PCN is required for any culvert rehabilitation project that includes a culvert which is not in compliance with General Conditions #2 and/or #9 (i.e. impedes aquatic life movement or water flow) and which will not be corrected by the proposed repair.
- d. A PCN is required for culvert rehabilitation projects which will involve pipe slip lining or other activities, including concrete invert paving and concrete lining that raise the existing invert elevation such that it causes an impediment to the passage of low flow or aquatic life movement. Slip lining is defined as the insertion of a smaller diameter pipe into an existing pipe by pulling pushing, or spiral winding.

**Preconstruction Notification (PCN) Requirements:**

In addition to the PCN requirements of General Condition #32, the PCN must include the following information:

- i. A summary of the evaluation required in Item a. above including a discussion of the impediment(s) to aquatic life movement and/or water flow.
- ii. Information as to how the proposal will mitigate for the impediment. Mitigation measures may include, but are not limited to baffles, weirs, roughened channels, and grade control structures.

**G-C.** No regulated activity authorized by a Nationwide Permit can cause the loss of areas classified as a bog or fen in the State of New York, as determined by the Buffalo or the New York District Corps of Engineers, due to the scarcity of this habitat in New York State and the difficulty with in-kind mitigation. The Districts will utilize the following document in the classification:

Reschke, C. 1990. *Ecological Communities of New York State*. New York Natural Heritage Program. New York State Department of Environmental Conservation. Latham, N.Y. 96p. This document is available at the following location: <http://www.dec.ny.gov/animals/29389.html>

**G-D. National Wild and Scenic Rivers (NWSR):** The Upper Delaware River has been designated as a National Wild and Scenic River from the confluence of the East and West Branches below Hancock, New York, to the existing railroad bridge immediately downstream of Cherry Island in the vicinity of Sparrow Bush, New York. Also, the portion of the Genesee River located within Letchworth Gorge State Park, beginning at the southern boundary of the park and extending downstream to the Mt. Morris Dam, was designated by Congress as a permanent Study River in the Genesee River Protection Act of 1989. In accordance with General Condition #16, no activity may occur within a NWSR, including Study Rivers, unless the National Park Service (NPS) has determined in writing that the proposed work will not adversely affect the NWSR designation or study status. Therefore, a PCN is required for any NWP which would impact the designated portions of the Genesee River or the Upper Delaware River, unless NPS has previously indicated the project will not adversely affect the waterway. (Note: the applicant may not commence work under any NWP until the NPS determines in writing that the project will not adversely affect the NWSR even if 45-days have passed since receipt of the PCN package.) Information regarding NWSR may be found at: <https://www.rivers.gov/new-york.php>

**G-E. For all proposals requiring a pre-construction notification (PCN), in addition to the requirements in General Condition #32, the applicant shall also include: (Note: the application will not be considered complete until all of the applicable information is received).**

- 1. New York State/USACE Joint Application Form:** The application form shall be completed and signed and shall clearly indicate that the submission is a PCN.  
(<http://www.lrb.usace.army.mil/Missions/Regulatory/Application-Forms/>)
- 2. Drawings:** The PCN must include legible, black and white project drawings on 8.5" x 11" paper. Full size drawings may be submitted in addition to the 8.5" x 11" plans to aid in the application review. Three types of illustrations are needed to properly depict the work to be undertaken. These illustrations or drawings are a Vicinity Map (i.e. a location map such as a USGS topographical map), a Plan View and a Cross-Section Map. Each illustration should identify the project, the applicant, and the type of illustration (vicinity map, plan view or cross section). The Vicinity Map shall provide the location of the entire project site. In addition, each illustration should be identified with a figure or attachment number. The location map shall include the Latitude and Longitude or UTM coordinates of the project. For linear projects, the PCN shall include a map of the entire project including a delineation of all waters of the United States within the corridor. Aquatic resource information shall be submitted using the Cowardin Classification System mapping conventions (e.g. PFO, PEM, etc.)
- 3. Color photographs:** The photos should be sufficient to accurately portray the project site, keyed to a location map and not taken when snow cover is present.

**4. Avoidance and Minimization:** The PCN must include a written narrative explaining how avoidance and minimization of temporary impacts and permanent losses of waters of the United States were achieved on the project site (i.e. site redesign, reduction in scope, alternate methods, etc.). It should include a description of the proposed construction practices that would be implemented to perform the proposed work and a description of the reasonably foreseeable direct and indirect effects to waters of the United States from the proposed construction practices.

**5. Mitigation** (See General Conditions #23 and #32(b)(6)): The PCN must include at least a conceptual compensatory mitigation plan for all projects resulting in the loss of greater than 1/10<sup>th</sup> of an acre of waters of the United States; or for which a waiver of the 300 linear foot limit on intermittent and ephemeral streams is being requested. Mitigation conceptual plans submitted with the PCN must include the following information at a minimum: proposed compensation type (bank or in-lieu fee credit, restoration, creation, preservation, etc.), location and brief discussion on factors considered for site selection (i.e., soils, water source, potential for invasive species, etc.), amount proposed per resource type and a discussion of how the proposal will compensate for aquatic resource functions and services lost as a result of the project.

Note 1: All mitigation projects must comply with the Federal Regulations on compensatory mitigation (33 CFR 332) entitled “Compensatory Mitigation for Losses of Aquatic Resources: Final Rule”, dated April 10, 2008, which is available at:

<http://www.lrb.usace.army.mil/Portals/45/docs/regulatory/MitandMon/FinalMitigaitonRuleApril2008.pdf> and any applicable District Guidelines.

Note 2: Although a conceptual mitigation plan may be sufficient for the purposes of a PCN submission, a detailed mitigation plan must be approved by the Corps before any jurisdictional work may occur on the project site.

Note 3: If more than 0.10 acres of designated EFH habitat (as discussed in Section G-E.8. below) would be impacted such that habitat would be lost, compensatory mitigation at a minimum ratio of 1:1 is required. A ratio of more than 1:1 may be required depending upon the ecological value of the habitat to be lost or degraded and the form of compensatory mitigation proposed to be provided.

**6. Nationwide Rivers Inventory:** The PCN shall indicate if a river segment listed within the National Park Service Nationwide Rivers Inventory (NRI) is located within the proposed project area. For project areas containing a listed NRI segment, the PCN shall also include a statement as to how adverse effects to the river have been avoided or mitigated. The list is available at: <http://www.nps.gov/ncrc/programs/rtca/nri/states/ny.html>.

**7. Historic or Cultural Resources:** In accordance with General Condition #20, a PCN is required for any non-federal activity which may have the potential to cause effects to any historic properties\* listed, determined to be eligible for listing on, or potentially eligible for listing on the National Register of Historic Places (NR). Please refer to General Condition #20 for submission requirements. In addition, all PCNs must include:

- A written statement indicating if any such properties may be affected by the proposed project.
- A copy of any completed archaeology or building/structure survey reports. If a survey has not been performed, the statement shall include a list of resources checked in the determination.
- Copies of any available correspondence from the New York State Office of Parks, Recreation, and Historic Preservation State Historic Preservation Officer (SHPO) regarding historic properties.
- Copies of any available correspondence from federally recognized Indian Nations regarding historic properties that may be affected by the project.

- Projects with ground disturbance may have the potential to cause effects to buried historic properties, regardless of occurring outside SHPO designated archaeological sensitive areas. Therefore, the PCN shall indicate if the ground disturbance will occur in any areas of previously undisturbed soil. For areas with prior disturbance, the PCN shall include a brief narrative describing the disturbance and its limit (i.e. type of disturbance, size of area with current undisturbed soil, size of area with existing disturbed soils, when the disturbance occurred, an estimate on how deep the soil disturbance extends, etc.) as well as photos of the existing ground disturbance.
- Above ground buildings/structures that are over 50 years old and potentially affected by the project will need to be assessed to determine if they are eligible for the NR. The PCN shall: identify any structures present in the project area, which have not already been subject to SHPO review, include photos of the structures, and describe how the project would/would not affect them.

\* - see NWP definition section for further clarification

NOTE 1: Information regarding historic properties may be found at: <https://cris.parks.ny.gov>. In addition, assistance regarding the determination of the presence of historic or cultural resources at or near the project site should be directed to SHPO.

NOTE 2: as stated in General Condition #20, if any listed, eligible or potentially eligible properties are present, the applicant shall not begin the activity until notified by the district engineer in writing either that the activity has no potential to cause effects or that consultation under Section 106 of the NHPA has been completed.

**8. Endangered Species and Essential Fish Habitat:** In accordance with General Condition #18, non-federal applicants must submit a PCN if any listed species or designated critical habitat might be affected or is in the vicinity of the activity, or if the activity is located in designated critical habitat. Please refer to General Condition #18 for submission requirements. In addition, all PCNs must include:

- a written statement and documentation concerning any Essential Fish Habitat (EFH) and any federally listed or proposed Threatened, Endangered, or Candidate (TE&C) species or designated and/or proposed critical habitat that might be affected or located in the vicinity of the project.
- a copy of any correspondence from the U.S. Fish and Wildlife Service (USFWS) and/or National Oceanic and Atmospheric Administration Fisheries Service (NOAA-Fisheries), regarding the potential presence of TE&C species on the project site. USFWS TE&C website: <http://www.fws.gov/northeast/nyfo/es/section7.htm> . Information on NOAA-Fisheries (NMFS) species (both TE&C and EFH) can be found at: <https://www.greateratlantic.fisheries.noaa.gov/>
- an official TE&C species list printed within 90 days of the PCN submission from the USFWS Website.
- For projects where TE&C species are listed, a discussion of potential TE&C species habitat within the project site (See USFWS T&E website for species habitat information).
- If there is potential habitat for any TE&C species within the project site the following, as applicable, shall be submitted:
  - a. The results of any habitat surveys and presence/absence surveys. Note: all surveys should be coordinated with the USFWS and/or NOAA-Fisheries (NMFS) prior to initiation.



- b. A detailed description of the proposed project, including secondary impacts and approximate proposed project construction schedule of project activities (e.g. land clearing, utilities, stormwater management).
- c. A description of the natural characteristics of the property and surrounding area (e.g. forested areas, freshwater wetlands, open waters, and soils) and a description of surrounding land use (residential, agricultural, or commercial).
- d. A description of the area to be impacted by the proposed project, including the species, typical sizes (d.b.h.) and number or acres of trees to be removed.
- e. The location of the above referenced property and extent of any project related activities or discharges clearly indicated on a copy of a USGS 7.5 minute topographic quadrangle (quad) with the name of the quad(s) and latitude/longitude clearly labeled.
- f. A description of conservation measures to avoid, minimize and/or mitigate impacts to listed species.

**NOTE 1:** There are no known TE&C species or EFH species under the jurisdiction of the NOAA-Fisheries (NMFS) within the Buffalo District. Therefore, all Buffalo District requests for information regarding the presence of TE&C species should be directed to the USFWS. In addition, no EFH review is necessary within the following New York District counties: Clinton, Essex, Franklin, Fulton, Hamilton, Montgomery, Otsego, Schenectady, Schoharie and Warren.

**NOTE 2:** Please refer to the following website for further guidance and information relating to regulatory permits & TE&C species in New York:  
<http://www.lrb.usace.army.mil/Missions/Regulatory/Endangered-Species/Endangered-Species-New-York/>

**NOTE 3:** General Condition #18 is emphasized, ...”In cases where the non-Federal applicant has identified listed species or critical habitat that might be affected or is in the vicinity of the project, and has so notified the Corps, the applicant shall not begin work until the Corps has provided notification the proposed work will have “no effect” on listed species or critical habitat, or until Section 7 consultation has been completed.”

**9. 100 Year Floodplain:** For permanent fills within waters of the United States within the 100 year floodplain, documentation of compliance with FEMA-approved state or local floodplain management requirements.

**10. Submission of Multiple Copies of PCN:**

- a) One (1) additional copy of the application drawings shall be provided to USACE for coordination with National Oceanic and Atmospheric Administration (NOAA) for utility lines to be constructed or installed in navigable waters of the United States proposed under NWP #12, (See Note 1 of NWP #12)
- b) One (1) additional copy of the PCN package shall be provided to USACE for coordination with Department of Defense Siting Clearinghouse (See NWPs #12, 39, 51 & 52 Notes) for:
  - i. overhead utility lines proposed under NWP #12 and
  - ii. any activity that involves the construction of a wind energy generating structure, solar tower, or overhead transmission lines proposed under NWPs #39, 51 or 52
- c) Two (2) additional copies of the PCN package shall be provided to USACE when the project is located within the New York City Watershed, for coordination with the New York City Department of Environmental Protection.

- d) Five (5) additional copies of the PCN package shall be submitted to USACE for agency coordination in accordance with General Condition #32(d)(2) for:
- i. All NWP activities that result in the loss of greater than 1/2-acre of waters of the United States,
  - ii. NWPs #21, 29, 39, 40, 42, 43, 44, 50, 51, and 52 activities that will result in the loss of greater than 300 linear feet of intermittent & ephemeral stream bed,
  - iii. NWP #13 activities in excess of 500 linear feet, fills greater than one cubic yard per running foot, or involve discharges of dredged or fill material into special aquatic sites;
  - iv. NWP #54 activities in excess of 500 linear feet or that extend into the waterbody more than 30 feet from the mean low water line in tidal waters or the ordinary high water mark in the Great Lakes.

#### **G-F. CRITICAL RESOURCE WATERS**

In accordance with NWP General Condition #22, certain activities in Critical Resource Waters cannot be authorized under the NWP program or would require a PCN (see General Condition #22 for a list of the NWP activities that are either excluded or require a PCN).

Critical Resource Waters in New York State include the following:

1. **East-of-Hudson portion of the New York City Water Supply:** This area includes portions of Dutchess, Putnam and Westchester Counties as delineated on Enclosure 2.
2. **Hudson River National Estuarine Research Reserves (NERR):** The Hudson River NERR consists of four components: Piermont Marsh, Iona Island, Tivoli Bay, and Stockport Flats.

#### **H. NYSDEC General Water Quality Certification (WQC) Conditions applicable to all NWPs for which WQC has been provided are as follows:**

##### 1. Non-contamination of Waters

- All necessary precautions shall be taken to preclude contamination of any wetland or waterway by suspended solids, resins, sediments, fuels, solvents, lubricants, epoxy coatings, paints, concrete, leachate, inadvertent returns of drilling muds (frac-outs) or any other environmentally deleterious materials associated with the project.

##### 2. Installation and Replacement of Culverts

To be covered under this blanket Water Quality Certification, all of the following criteria must be met:

- Culvert pipes shall be designed to safely pass a 2% annual chance storm event.
- This certification does not authorize the installation of any culverts that are not embedded beneath the existing grade of the stream channel.
- Width of the structure must be a minimum of 1.25 times (1.25x) width of the Mean (Ordinary) High Water Channel.
- The culvert bed slope shall remain consistent with the slope of the adjacent stream channel. For slopes greater than 3%, an open bottom culvert must be used.
- This certification does not authorize work on culverts that provide sole access to “Critical Facilities”: An individual WQC must be obtained for work on these culverts.

- This certification does not authorize culvert rehabilitation projects that involve slip lining, or similar treatments.
- This certification does authorize the rehabilitation of culverts utilizing Cure in Place Pipe Lining (CIPP) or concrete spray lining for culverts which currently meet Nationwide Permit General Condition #2 - Aquatic Life Movements.

### 3. Discharge and Disturbance Limits of the Blanket WQC

- For Nationwide Permits # 5, 7, 12, 13, 14, 15, 18, 19, 23, 25, 29, 31, 32, 34, 36, 37, 39, 40, 42, 45, 46, 48, 51, utility line replacement projects under Nationwide Permit #3 and non-maintenance activities under Nationwide Permit #43.
- The following discharge limits apply:
  - a) Temporary or permanent discharges of dredged or fill material into wetlands and other waters of the U.S. must not exceed ¼ acre;
  - b) Temporary or permanent impacts (i.e., loss) to stream beds must not exceed 300 linear feet.
  - c) The discharge area limit under paragraph (a) plus the equivalent stream impact area limit under paragraph (b) must not exceed ¼ acre total.
- For Nationwide Permits #3, 4, 6, 20, 22, 27, 30, 33, 41 and maintenance activities under Nationwide Permit #43, this certification authorizes discharges and disturbances up to the limit of the respective Nationwide Permit or Regional Conditions, whichever is most restrictive.
- If a project requiring coverage under two or more Nationwide Permits results in a temporary or permanent discharge or disturbance, the most restrictive threshold applies to the project.

### 4. Bulkheads

- This certification does not authorize the construction of new bulkheads or vertical walls.
- This certification does not authorize the waterward extension of existing bulkheads.
- New toe-stone protection may not extend more than 36 inches waterward from the existing bulkhead face.

### 5. Maintenance of Water Levels

- This certification does not authorize any activity that results in a permanent water level alteration in waterbodies, such as draining or impounding, with the exception of activities authorized by Nationwide Permit #27.

### 6. Dewatering

- Authorized dewatering is limited to immediate work areas that are within coffer dams or otherwise isolated from the larger waterbody or waters of the United States.
- Dewatering must be localized and must not drain extensive areas of a waterbody or reduce the water level such that fish and other aquatic organisms are killed, or their eggs and nests are exposed to desiccation, freezing or depredation in areas outside of the immediate work site.
- Cofferdams or diversions shall not be constructed in a manner that causes or exacerbates erosion of the bed or banks of a waterbody.
- All dewatering structures must be permanently removed and disturbed areas must be graded and stabilized immediately following completion of work. Return flows from the dewatering structure shall be as visibly clear as the receiving waterbody.

### 7. Endangered or Threatened Species

- This certification does not authorize projects likely to result in the take or taking of any species listed as endangered or threatened species listed in 6 NYCRR Part 182.5 (a), (b) or projects likely to destroy or adversely modify the habitat of such species. Applicants must either verify that the activity is outside of the occupied habitat of such species or, if located within the habitat of such species, obtain a determination from the NYS Department of Conservation Regional Office that the proposed activity will not be likely to result in the take or taking of any species listed as endangered or threatened species listed in 6 NYCRR Part 182. Information on New York State endangered or threatened species may be obtained from the NYS Department of Environmental regional offices, the New York Natural Heritage Program in Albany, New York or on the DEC website at <http://www.dec.ny.gov/animals/29338.html>

If it is determined that the project is likely to result in the take of (or modify the habitat of such species) a New York listed endangered or threatened species, then this blanket water quality certification is not applicable, and the applicant will need an individual water quality certification from the department.

#### 8. Rare Mollusks

- This Certification may not be issued for and does not authorize disturbances or discharges to waters of the state listed as supporting mollusks S-1 or S-2 on the New York State Natural Heritage database. <http://www.dec.ny.gov/animals/29338.html>

#### 9. Prohibition Period for In-water Work

In-water work is prohibited during the following time period:

- in cold water trout fisheries (waterbodies classified under Article 15 of New York State Environmental Conservation Law with a "t" or "ts" designation), beginning October 1 and ending May 31.

To determine if the prohibition period is in effect for a particular water, contact the Regional Natural Resources Supervisor in the appropriate New York State Department of Environmental Conservation regional office. Water Classification values can be determined on the DEC's Environmental Resource Mapper available on the Departments Website @ <http://www.dec.ny.gov/gis/erm/> Work windows may be extended by the Regional Natural Resources Supervisor or their designee.

#### 10. Significant Coastal Fish and Wildlife Habitat

- This certification does not authorize any discharge occurring in a designated Significant Coastal Fish and Wildlife Habitat area pursuant to 19 NYCRR Part 602; Title 19 Chapter 13, Waterfront Revitalization and Coastal Resources. <https://www.dos.ny.gov/opd/programs/consistency/scfwhabitats.html>

#### 11. Coastal Erosion Hazard Areas

- This certification does not authorize projects in Coastal Erosion Hazard Areas, as identified in New York State Environmental Conservation Law Article 34, and its implementing regulations, 6 NYCRR Part 505. <http://www.dec.ny.gov/lands/86541.html>

#### 12. State-owned Underwater Lands

Prior to undertaking any Nationwide Permit activity that will involve or occupy state-owned lands now or formerly under the waters of New York State, the party proposing the activity must first obtain all necessary approvals from:

New York State Office of General Services  
Division of Real Estate Development  
Corning Tower Building, 26th Floor  
Empire State Plaza  
Albany, NY 12242  
Tel. (518) 474-2195

#### 13. Tidal Wetlands

- This certification does not authorize any activities in tidal wetlands as defined in Article 25 of New York State Environmental Conservation Law, with the exception of activities authorized by Nationwide Permits #4, 20 and 48. <http://www.dec.ny.gov/lands/4940.html>

14. Wild, Scenic and Recreational Rivers

- This certification does not authorize activities in any Wild, Scenic or Recreational River pursuant to 6 NYCRR Part 666 or state designated Wild, Scenic or Recreational River corridors. <http://www.dec.ny.gov/permits/6033.html>

15. Floodplains

- Authorized projects subject to this certification must first be in compliance with State and Local Floodplain Regulations prior to commencement of construction.

16. Public Service Commission

- This certification does not authorize activities regulated pursuant to Article VII or Article 10 of the New York State Public Service Law. For such projects, Section 401 Water Quality Certification is obtained from the New York State Public Service Commission.

17. Utility Projects

- This certification does not authorize maintenance or other activities associated with hydroelectric power generation projects.
- This certification does not authorize the construction of substation facilities or permanent access roads in wetlands.
- Excess materials resulting from trench excavation must be permanently removed from the waters of the United States and contained so that they do not re-enter any waters of the United States.

18. Preventing the Spread of Terrestrial and Aquatic Invasive Species

- To prevent the unintentional introduction or spread of invasive species, the permittee must ensure that all construction equipment be cleaned of mud, seeds, vegetation and other debris before entering any approved construction areas within waters of the United States. When using construction equipment projects authorized under this Certification shall take reasonable precautions to prevent the spread of aquatic invasive species as required under the provisions in ECL § 9-1710.

**I. New York State Department of State (NYS DOS) Coastal Zone Management Consistency Determination Additional Information (applicable to all NWP's located within or affecting the NYS Coastal Zone):**

Where NYSDOS has objected to the USACE consistency determination or where the project will not comply with the NYSDOS NWP specific condition(s), as outlined in the specific NWP listing in Section B above, the applicant must submit a request for an individual consistency determination to NYSDOS. See Section K for NYSDOS contact information.

Further Information:

- Unless NYSDOS issues consistency concurrence or USACE has determined that NYSDOS concurrence is presumed, NWP's are not valid within the Coastal Zone.
- All consistency concurrence determination requests must be submitted directly to NYSDOS with a copy provided to USACE with any required Preconstruction Notification submissions.
- Limits of the coastal zone and details regarding NYSDOS submission requirements, including application forms can be obtained at: <https://www.dos.ny.gov/opd/programs/consistency/index.html>

**J. INFORMATION ON NATIONWIDE PERMIT VERIFICATION**

Verification of the applicability of these Nationwide Permits is valid until March 18, 2022 unless the Nationwide Permit is modified, suspended revoked, or the activity complies with any subsequent permit modification.

It is the applicant's responsibility to remain informed of changes to the Nationwide Permit program. A public notice announcing any changes will be issued when they occur and will be available for viewing at our website: <http://www.lrb.usace.army.mil/Missions/Regulatory.aspx>.

Please note in accordance with 33 CFR part 330.6(b), that if you commence or are under contract to commence an activity in reliance of the permit prior to the date this Nationwide permit expires, is suspended or revoked, or is modified such that the activity no longer complies with the terms and conditions, you have twelve months from the date of permit modification, expiration, or revocation to complete the activity under the present terms and conditions of the permit, unless the permit has been subject to the provisions of discretionary authority.

Possession of this permit does not obviate you of the need to contact all appropriate state and/or local governmental officials to insure that the project complies with their requirements.

## **K. AGENCY CONTACT INFORMATION**

### **NYS Department of Environmental Conservation**

[www.dec.ny.gov](http://www.dec.ny.gov)

#### **NYS DEC REGION 1**

Regional Permit Administrator  
SUNY @ Stony Brook  
50 Circle Road  
Stony Brook, NY 11790-3409  
(631) 444-0365

#### **NYS DEC REGION 2**

Regional Permit Administrator  
1 Hunter's Point Plaza  
47-40 21st Street  
Long Island City, NY 11101-5407  
(718) 482-4997

#### **NYS DEC REGION 3**

Regional Permit Administrator  
21 South Putt Corners Road  
New Paltz, NY 12561-1620  
(845) 256-3054

#### **NYS DEC REGION 4**

Regional Permit Administrator  
1130 North Westcott Road  
Schenectady, NY 12306-2014  
(518) 357-2069

#### **NYS DEC REGION 4 Sub-Office**

Deputy Regional Permit Administrator  
65561 State Hwy 10  
Stamford, NY 12167-9503  
(607) 652-7741

#### **NYS DEC REGION 5**

Regional Permit Administrator  
PO Box 296  
1115 Route 86  
Ray Brook, NY 12977-0296  
(518)897-1234

#### **NYS DEC REGION 5 Sub-Office**

Deputy Regional Permit Administrator  
PO Box 220  
232 Golf Course Rd  
Warrensburg, NY 12885-0220  
(518) 623-1281

#### **NYS DEC REGION 6**

Regional Permit Administrator  
317 Washington Street  
Watertown, NY 13601-3787  
(315) 785-2245

#### **NYS DEC REGION 6 Sub-Office**

Deputy Regional Permit Administrator  
207 Genesee Street  
Utica, NY 13501-2885  
(315) 793-2555

#### **NYS DEC REGION 7**

Regional Permit Administrator  
615 Erie Blvd. West  
Syracuse, NY 13204-2400  
(315)426-7438

#### **NYS DEC REGION 7 Sub-Office**

Deputy Regional Permit Administrator  
1285 Fisher Avenue  
Cortland, NY 13045-1090  
(607) 753-3095

#### **NYS DEC REGION 8**

Regional Permit Administrator  
6274 E. Avon - Lima Road  
Avon, NY 14414-9519  
(585) 226-2466

#### **NYS DEC REGION 9**

Regional Permit Administrator  
270 Michigan Avenue  
Buffalo, NY 14203-2915  
(716) 851-7165

#### **NYS DEC REGION 9 Sub-Office**

Deputy Regional Permit Administrator  
182 East Union Street  
Allegany, NY 14706-1328  
(716) 372-0645

### **NYS Department of State**

Division of Coastal Resources  
Consistency Review Unit  
One Commerce Plaza  
99 Washington Avenue, Suite 1010  
Albany, NY 12231-00001  
(518) 474-6000  
<https://www.dos.ny.gov/opd/programs/consistency/index.html>

### **US Army Corps of Engineers**

<http://www.nan.usace.army.mil>

(For DEC Regions 1, 2 and 3)

#### **US Army Corps of Engineers NY District**

ATTN: Regulatory Branch  
26 Federal Plaza, Room 1937  
New York, NY 10278-0090  
Email: [CENAN.PublicNotice@usace.army.mil](mailto:CENAN.PublicNotice@usace.army.mil)  
For DEC Regions 1, 2, Westchester County  
and Rockland County (917) 790-8511  
For the other counties of DEC Region 3 -  
(917) 790-8411

(For DEC Regions 4, 5)

#### **Department of the Army**

ATTN: **CENAN-OP-R**  
**NY District, Corps of Engineers**  
1 Buffington Street  
Building 10, 3<sup>rd</sup> Floor  
Watervliet, NY 12189-4000  
(518) 266-6350 - Permits team  
(518) 266-6360 - Compliance Team

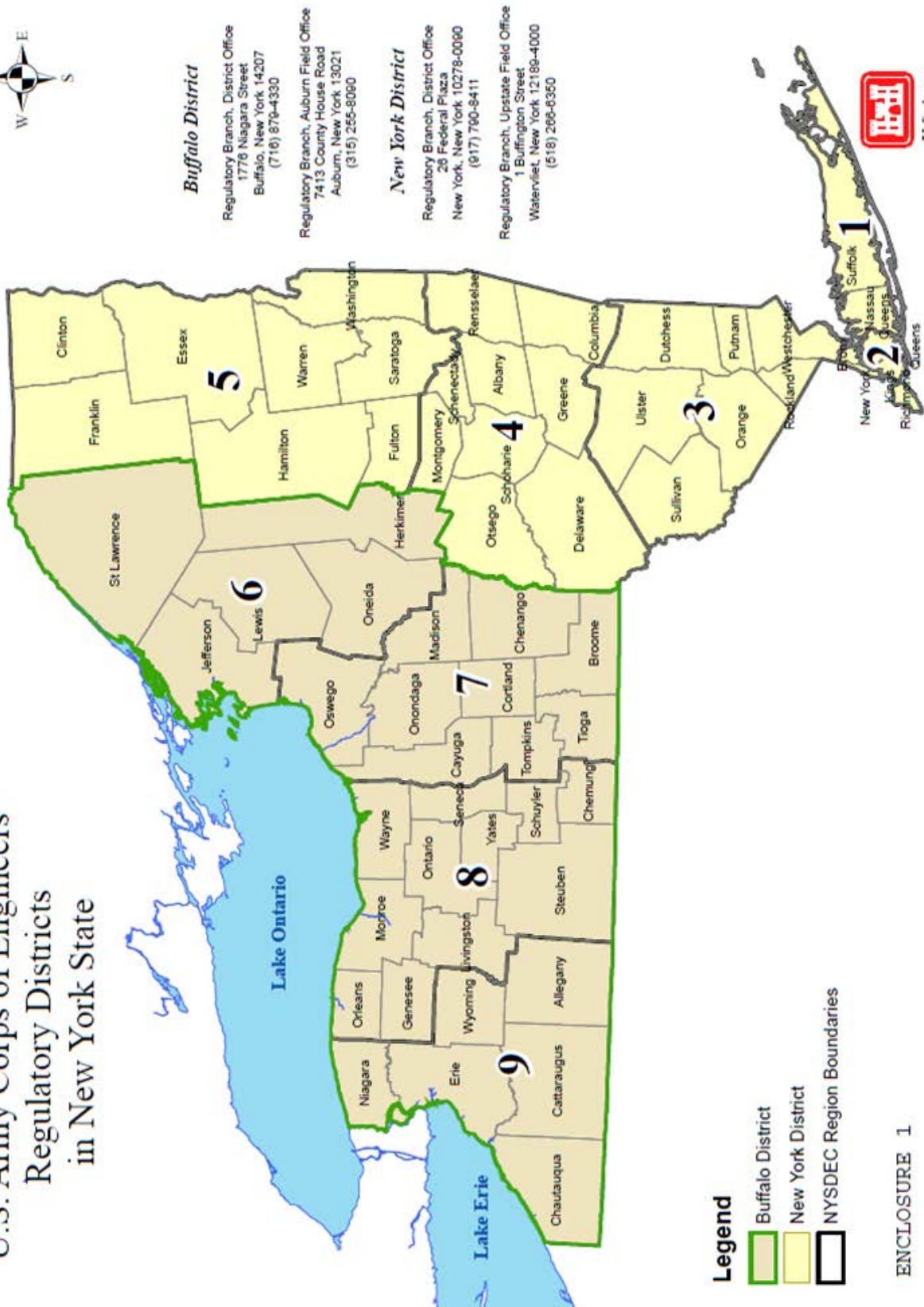
Email: [cenan.rfo@usace.army.mil](mailto:cenan.rfo@usace.army.mil)

(For DEC Regions 6, 7, 8, 9)

#### **US Army Corps of Engineers**

**Buffalo District**  
ATTN: Regulatory Branch  
1776 Niagara Street  
Buffalo, NY 14207-3199  
(716) 879-4330  
Email: [LRB.Regulatory@usace.army.mil](mailto:LRB.Regulatory@usace.army.mil)  
[www.lrb.usace.army.mil](http://www.lrb.usace.army.mil)

# U.S. Army Corps of Engineers Regulatory Districts in New York State



## *Buffalo District*

Regulatory Branch, District Office  
1776 Niagara Street  
Buffalo, New York 14207  
(716) 879-4330

Regulatory Branch, Auburn Field Office  
7413 County House Road  
Auburn, New York 13021  
(315) 266-8090

## *New York District*

Regulatory Branch, District Office  
28 Federal Plaza  
New York, New York 10278-0090  
(917) 760-8411

Regulatory Branch, Upstate Field Office  
1 Buffington Street  
Watervliet, New York 12189-4000  
(518) 266-6350

### Legend

- Buffalo District
- New York District
- NYSDEC Region Boundaries

ENCLOSURE 1



U.S. Army  
Corps of Engineers

ENCLOSURE 2



## Section 4

<b>DEFINITIONS AND TERMS</b>
------------------------------

---

---

---

---

---

---

---

---

---

---

---

---

---

---

---

---

---

---

---

---

---

---

---

---

**This Page Left Intentionally Blank**

## DEFINITIONS AND TERMS

Same as Section 101 of the New York State Department of Transportation Standard Specifications and all addenda.

References to the County's representative "Stantec" and County personnel shall hereinafter be made as the "Engineer".

Under this contract the New York State Department of Transportation, Office of Engineering, Standard Specifications, Construction and Materials and addenda are amended as follows:

Under Section 101-02 – Definitions and Terms

1. Chief Engineer  
Delete the stated definition. This term where used in the specifications or contract documents shall mean the "Cattaraugus County Commissioner of Public Works" or his authorized representative.
2. Commissioner  
Delete the stated definition. This term where used in the specifications or contract documents shall mean the "Cattaraugus County Commissioner of Public Works".
3. Department  
Delete the stated definition. This term where used in the specifications or contract documents shall mean "Cattaraugus County Department of Public Works" and may also be used to mean the "Commissioner of Public Works" or his authorized representative.
4. Departmental Geotechnical Engineer  
Delete the stated definition. This term where used in the specifications or contract documents shall mean the "Cattaraugus County Commissioner of Public Works" or his authorized representative.
5. Departmental Engineering Geologist  
Delete the stated definition and substitute the same definition as above for Departmental Geotechnical Engineer.
6. Division  
Delete the stated definition and insert: "Cattaraugus County Department of Public Works".
7. Engineer or Engineer-In-Charge  
Delete the words "Department of Transportation" and substitute "Cattaraugus County Department of Public Works". Also delete the words "Regional Director" and substitute "Cattaraugus County Commissioner of Public Works".
8. Final Agreement  
Delete "State of New York, Department of Transportation" and substitute "Cattaraugus County Department of Public Works".
9. Inspector  
Delete "The Department of Transportation" and substitute "The authorized representative of Cattaraugus County Department of Public Works".

10. **Materials Bureau**  
Delete the words “Materials Bureau” and the stated definition and substitute “Cattaraugus County Department of Public Works has the responsibility in the quality assurance for materials to be used on the contract”.
11. **Regional Director**  
Delete the stated definition and substitute: “When used, means the Cattaraugus County Commissioner of Public Works”.
12. **State**  
Delete the stated definition and substitute: “When used, means the County of Cattaraugus , represented through the Cattaraugus County Department of Public Works” through the Commissioner of Public Works .

Under Section 102 – Bidding Requirements and Conditions

13. **Subsection 102-01, Location of Regional Offices**  
Delete entire subsection -- not applicable.
14. **Subsection 102-06, Bid Deposit**  
Delete from the second and third lines the words “State of New York”, and substitute “County of Cattaraugus”.

## Section 5

<b>SPECIAL NOTES</b>
----------------------

The following notes are to supplement the NYSDOT Standard Specifications. If any of the Notes are in conflict with the NYSDOT Standard Specifications, the NYSDOT Standard Specifications shall prevail and take precedence and be of force over and against any said conflicting Notes.

INSURANCE REQUIREMENTS

---

COORDINATION WITH THE UTILITY SCHEDULE

---

ASSIGNMENT OF AUTHORITY

---

SAFETY AND HEALTH REQUIREMENTS – WORKER SILICA PROTECTION

---

CATTARAUGUS COUNTY VENDOR RESPONSIBILITY FORM

---

DELIVERY OF BIDS

---

DISQUALIFICATION OF BIDDERS

---

QUALIFICATION OF APPARENT LOW BIDDER

---

RETURN OF PROPOSAL GUARANTY

---

BONDS

---

FAILURE TO EXECUTE CONTRACT

---

RESPONSIBILITY OF THE CONTRACTOR

---

AUTHORITY OF ENGINEER

---

SUBSTANTIAL COMPLETION AND FINAL ACCEPTANCE OF WORK

---

CONTRACTOR'S PERSONNEL

---

*NOTE: This form was developed for repetitive use throughout all contract proposals and may identify items not applicable to this specific project.*

## Section 5

<b>SPECIAL NOTES</b>
----------------------

The following notes are to supplement the NYSDOT Standard Specifications. If any of the Notes are in conflict with the NYSDOT Standard Specifications, the NYSDOT Standard Specifications shall prevail and take precedence and be of force over and against any said conflicting Notes.

MATERIAL CERTIFICATES OF ACCEPTABILITY

SUBCONTRACTORS, MATERIALMEN AND LABORERS

RESPONSIBILITY FOR DAMAGE CLAIMS

NO WAIVER OF LEGAL RIGHTS

LITIGATION

NOTICE TO PROCEED

PROSECUTION OF WORK

TEMPORARY SUSPENSION OF WORK

DATE OF COMPLETION OF CONTRACT WORK

TERMINATION OF CONTRACT

FAILURE TO COMPLETE WORK ON TIME

ASSIGNMENT

PAYMENTS ON CONTRACT

DIFFERING SITE CONDITIONS

OPERATIONAL DAMAGES

*NOTE: This form was developed for repetitive use throughout all contract proposals and may identify items not applicable to this specific project.*

## Section 5

<b>SPECIAL NOTES</b>
----------------------

The following notes are to supplement the NYSDOT Standard Specifications. If any of the Notes are in conflict with the NYSDOT Standard Specifications, the NYSDOT Standard Specifications shall prevail and take precedence and be of force over and against any said conflicting Notes.

EXCAVATION

---

SITE SAFETY

---

PRECONSTRUCTION CONFERENCE AND PROJECT SCHEDULE

---

SPECIALTY ITEMS IN THIS CONTRACT

---

REQUIRED NOTICES

---

ENVIRONMENTAL CONCERNS

---

PERFORMANCE GRADED (PG) BINDER AND MIX DESIGN LEVEL

---

BITUMINOUS SEALER

---

SHOP DRAWINGS

---

ASBESTOS

---

REMOVAL OF COUNTY, TOWN OR VILLAGE-OWNED FACILITIES

---

EXISTING CONDITIONS

---

ENGINEER'S FIELD OFFICE – INTERNET SERVICE

---

OFFICE TECHNOLOGY AND SUPPLIES

---

HOLIDAYS

---

*NOTE: This form was developed for repetitive use throughout all contract proposals and may identify items not applicable to this specific project.*





## **INSURANCE REQUIREMENTS**

The Contractor shall procure and maintain at its own expense and without expense to the County, until final acceptance by the County, of the work covered by the contract, insurance for liability for damages imposed by law, of the kinds and in the amounts shown in the Insurance Requirement Checklist for County of Cattaraugus (Section 8), with insurance companies authorized to do such business in the County covering all operations under the contract whether performed by it or its subcontractors. Before commencing the work the Contractor shall furnish to the Commissioner of Public Works a certificate or certificates of insurance in form satisfactory to the Commissioner of Public Works showing that it has complied with this Section, which certificate or certificates shall provide that the policies shall not be changed or canceled until thirty (30) days written notice has been given to the Commissioner of Public Works. The types of insurance are as follows:

- A. **Workers' Compensation Insurance.** A policy covering the obligations of the Contractor in accordance with the provisions of the Workers' Compensation Law, covering all operations under the contract, whether performed by it or its subcontractor and also under the Disability Benefits Law. The contract, shall be void and of no effect unless the person or corporation making or executing same shall secure compensation and disability benefits coverage for the benefit of, and keep insured during the life of the contract, such employees in compliance with the provisions of the Workers' Compensation Law (State Finance Law Section 142).
- B. **Liability and Property Damage Insurance.** Policies following the 1986 Insurance Services Office formats shall be provided. Unless otherwise specifically required by special provision, each policy shall not be amended or contain deductible clauses or coverage exclusions of any nature.

Coverage for all damages arising during the policy period, shall be furnished in the types (a.) through (e.) as described below. An umbrella type policy, dedicated to this contract, may be used to meet these limits.

- a1. Contractor's Liability Insurance issued to and covering the liability for damages imposed by law upon the Contractor with respect to all work performed by him/her under the agreement;
- a2. Contractor's Liability Insurance issued to and covering the liability for damages imposed by law upon EACH SUBCONTRACTOR with respect to all work performed by said subcontractor under the agreement;
- b. Contractor's Protective Liability Insurance issued to and covering the liability for damages imposed by law upon the Contractor with respect to all work under the agreement performed for the Contractor by subcontractors;
- c. Completed Operations' Liability Insurance issued to and covering the liability for damages imposed by law upon the Contractor and each subcontractor arising between the date of final cessation of the work and the date of final acceptance thereof, out of that part of the work performed by each;

- d. Protective Liability Insurance issued to and covering the liability for damages imposed by law upon Cattaraugus County and all employees of the County both officially and personally, any municipality in which the work is being performed, and/or any public benefit corporation, railroad, or public utility whose property or facilities are affected by the work or any consultant inspecting engineer or inspector working for or on the project, and their agents or employees,, with respect to all operations under the agreement by the Contractor or its subcontractors, including omissions and supervisory acts of the County, municipality, public benefit corporation or consultant. Specifically, this includes, but is not necessarily limited to the parties listed below under coverage type A., Automobile Liability and Property Damage Insurance.

Failure to list a firm, organization or municipality, etc. does not eliminate the requirement to provide such coverage.

If the Contractor elects to use the same policy for more than one project, it must provide with the insurance certificate the Aggregate Limits of Insurance (per project) Endorsement indicating the specific project site and contract number;

- e. Commercial General Liability (Premises, Existence, Hazard) Liability Insurance (formerly called Owner's, Landlord's and Tenant's Liability Insurance) issued to and covering the liability for damages imposed by law upon Cattaraugus County and all employees of the County both officially and personally, any municipality in which the work is being performed, and/or any public benefit corporation, railroad, or public utility whose property or facilities are affected by the work or any consultant inspecting engineer or inspector working for or on the project, and their agents or employees, with respect to temporarily opening any portion of the County construction project under this agreement, until the construction or reconstruction pursuant to the agreement has been accepted by the County. Specifically, this includes, but is not necessarily limited to the parties listed below under coverage type A., Automobile Liability and Property Damage Insurance.

Failure to list a firm, organization or municipality, etc. does not eliminate the requirement to provide such coverage. This coverage will not be required for contracts involving only turf establishment, landscaping, or traffic signals, which do not involve work on the roadway.

- C. Automobile Liability and Property Damage Insurance. A policy covering the use in connection with the work covered by the Contract Documents of all owned, non-owned and hired vehicles bearing, or, under the circumstances under which they are being used, required by the Motor Vehicle Laws of the State of New York to bear license plates.”

List of Additional Insured Parties

State of New York / New York State Department of Transportation  
Cattaraugus County  
Village of Cattaraugus  
Town of New Albion  
Stantec Consulting Services Inc.

The above listing supplements Section 107-06 INSURANCE of the Standard Specifications.

Failure to list a firm, organization, or municipality, etc. does not eliminate the requirement to provide such coverage.

### **COORDINATION WITH THE UTILITY SCHEDULE**

The contractor must coordinate its schedule of operations with the various utility owners involved with the project and shall verify utility information found in the contract documents.

All known public and private utility installations within the Contract limits and their disposition are shown in their approximate locations on the Contract plans.

The Contractor is, however, cautioned that these locations are not guaranteed, nor is there any guarantee that all such facilities within the Contract limits have been shown on the plans. In this regard the Contractor's attention is called to Subsections 102-02 Paragraph C and 105-04 of the Standard Specifications.

Utilities encountered during the work shall be maintained and protected in their existing locations until otherwise provided for. If services or utility lines not shown on the plans are encountered, then excavation and grading shall be done with caution in order that these services not be disturbed until proper disposition of such is made by their owners. Damage by the Contractor to privately owned utilities shall be in all cases the responsibility of the Contractor. Relocation of public utilities and accessories is a responsibility of the servicing agency. Every reasonable attempt will be made by the agents of the Sponsor not to inconvenience or additionally cost the Contractor due to such relocation relating to time and/or place; however, no extra compensation will be made to the Contractor by the Sponsor for extra work or loss of time due to such utilities or the removal or relocation of such utilities.

The Contractor shall notify the Engineer, in writing, at least fourteen (14) days in advance of any work which may affect any utility or cause an interruption or disruption of utility service.

It shall be the Contractor's duty to notify all utility companies or other parties affected within a time frame as not to affect the schedule prior to all necessary adjustment of the public or private utility fixtures and other appurtenances within or adjacent to the limits of construction. The Contractor shall notify the Engineer in writing describing the need for, and extent of, utility adjustments and the anticipated schedule.

It is understood and agreed upon that the Contractor has considered in his/her bid all of the permanent and temporary utility appurtenances in their present or relocated positions as shown in the Contract Documents and that no additional compensation will be allowed for any delays, inconveniences, or damage sustained by him/her due to any interference from the utility appurtenances or the operation of moving them by the utility owners. The Contractor will be responsible for any fees required by the utility owners for temporary locations.

The contractor shall coordinate his schedule of operations with the various utility owners involved with the project and shall verify information found in the contract documents. Utility revisions required by the various utility owners in connection with this project include:

### **NATIONAL GRID - ELECTRIC**

National Grid currently maintains utility poles and aerial lines within the project limits these structures will be relocated before the start of the project.

### **VERIZON NY INC – TELEPHONE**

Verizon NY Inc currently maintains aerial telecommunications lines within the project limits on jointly owned poles. Verizon NY Inc will transfer their facilities prior to the start of construction.

### **VILLAGE OF CATTARAUGUS – SANITARY SEWER AND WATER**

The Village of Cattaraugus currently maintains a sanitary sewer and water service within the project limits.

As part of the project, the water service will be replaced and the sewer main will remain. The Contractor is responsible for providing temporary utility connections during the project as required.

**All requests for Village of Cattaraugus must go through (716-257-0151).**

In addition to the above itemized revisions, other revisions may become necessary during the construction stage as a result of more precise location data or other changes that might develop. These revisions are to be performed by the utility owners in coordination with the Contractor. Suitable time frames for these additions shall also be coordinated between the Contractor and the affected Utility. Such time frames are not to be included within previously established time frames.

The Contractor is governed by and must adhere to the provisions of 16 NYCRR Part 753 (Protection of Underground Facilities).

### **ASSIGNMENT OF AUTHORITY**

The Contract Documents reference the New York State Department of Transportation Standard Specifications as a supporting document. The New York State Department of Transportation (NYSDOT) Standard Specifications refer to NYSDOT employees and functional units within NYSDOT, to provide for approval or to perform functions specified in the Contract Documents. For this contract, the Local Project Sponsor will have full responsibility for the administration of the contract documents. For the purpose of this contract the Local Project Sponsor will designate a Responsible Local Official (RLO). If the RLO is not a Licensed Professional, he/she may still retain approval authority, if he/she is acting on a certification provided by a Licensed Professional.

Wherever the NYSDOT Standard Specifications refer to a NYSDOT employee for approval authority or to perform a contract function, the RLO or his/her designee will perform these duties. The RLO will have full approval Authority to award the Contract and administer the work under the Contract Documents, supported by a Licensed Professional certification where required.

## **SAFETY AND HEALTH REQUIREMENTS – WORKER SILICA PROTECTION**

Where the project requires the contractor to perform saw cutting, the Contractor is alerted to the fact that Concrete dust contains Crystalline Silica.

Crystalline Silica is a common substance, which is the basic component of many types of sands, quarts, and granite rock. Occupational exposure to Crystalline Silica can produce Silicosis.

The Contractor is alerted to the New York State Standard Specifications, Dated September 1, 2019, Section 107-05-L-4 and to OSHA requirements for Worker Silica Protection, included in 29 CFR 1926.55.

The Contractor Shall be in compliance with the New York State Standard Specifications, Dated September 1, 2019, Section 107-05, (Safety and Health Requirements).

## **CATTARAUGUS COUNTY VENDOR RESPONSIBILITY FORM**

Cattaraugus County Local Law 12-2012 as amended by Local Law 5-2015 requires that the County provide a copy of the Cattaraugus County Vendor Responsibility Form to the low bidder. The low bidder will have 5 business days to return the completed form unless the form was mailed by the county to the vendor, in which case will have 10 business days from the date of the mailing to return the form. Failure by the low bidder to submit the form within the above time frame will lead to the automatic rejection of their bid. The contractor must also ensure that all subcontractors to be used on the project complete this form and submit it to the County for approval within 5 days of the preconstruction meeting. Failure to do so may lead to the rejection of the subcontractor at the County's discretion. Within a reasonable time following its receipt of the completed CCA-2, and based on the information contained therein, information available from OHSA, DOL, federal and state databases of debarred firms, the state Corporate/Entity Database and other sources, its receipt of proof of the bidder's ability to secure required bonding and insurances, and its own independent investigation, the County will determine whether the bidder is a "responsible bidder" qualified to undertake and complete the Project.

Currently the Commissioner of Public Works has approved the CCA-2 (New York State Vendor Responsibility Questionnaire For-Profit Construction) with attachments A, B, and C to serve as the Cattaraugus County Vendor Responsibility Form.

## **DELIVERY OF PROPOSALS**

Each bid must be submitted in duplicate in a sealed envelope clearly marked to indicate its contents. Sealed bids must be delivered to the Cattaraugus County Commissioner of Public Works at or before the date, time and location specified herein. No responsibility shall be attached to the Commissioner of Public Works or his representatives for the premature opening of any bid not properly labeled. Bidders assume all responsibilities and risks associated with mail or courier delivery. When sent by mail, the sealed bid must be addressed to the County at the address and in care of the official in whose office bids are to be received. All bids shall be filed prior to the time and at the place specified in the "Notice to Bidders". Bids received after the time for opening of bids will be returned to the bidder unopened.

## **DISQUALIFICATION OF BIDDERS**

Any one or more of the following may be considered as sufficient cause for the disqualification of a bidder and the rejection of his bid.

- (a) More than one bid for the same work from an individual, firm or corporation under the same or different names.
- (b) Evidence of collusion among bidders. Participants in such collusion will receive no recognition as bidders for any future work with the County until any such participant shall have been reinstated as a qualified bidder.
- (c) Lack of competency and adequate machinery, plant and other equipment, as revealed by the financial statements and experience questionnaire.
- (d) Unsatisfactory performance record as shown by past work for any owner judged from the standpoint of workmanship and progress.
- (e) Uncompleted work which, in judgment of the County, might hinder or prevent the prompt completion of this work if awarded.
- (f) Failure to pay, or satisfactorily settle, all bills due for labor and materials on former contracts in force at the time of letting.
- (g) Failure to comply with any qualification regulations of the County.

## **QUALIFICATION OF APPARENT LOW BIDDER**

The apparent low bidder may be required to submit an itemized financial statement covering the previous twelve (12) calendar months of actual operations. If requested, the statement shall be submitted within three working days of bid opening. The statement shall include financial resources, liabilities, equipment, and experience of such a nature as to be acceptable to the Sponsor. Experience on projects of a similar nature may be taken into consideration in determining the lowest responsible bidder.

The Sponsor reserves the right to reject any bid if the evidence submitted by, or investigation of, such bidder fails to satisfy the Sponsor that such bidder is properly qualified to carry out the obligations of the contract and to complete the work contemplated therein. Conditional bids will not be accepted.

## **RETURN OF PROPOSAL GUARANTY**

All proposal guaranties, except those of the three lowest bidders, will be returned immediately following the opening and checking of the proposals. That of the successful bidder will be returned after a satisfactory bond has been furnished and the Contract has been executed. The remaining two guaranties will be returned within ten (10) calendar days following the award of the Contract.

## **BONDS**

The successful bidder shall at the time of the execution of the Contract, furnish a Faithful Performance Bond and a Labor and Materials Bond each in an amount equal to the full amount

of the Contract. The purpose of such bonds is to assure the faithful performance of this Contract as well as the payment of all persons performing labor and furnishing materials in connection with this Contract. The form of the bonds and the security shall be acceptable to the Sponsor.

Negotiable securities, satisfactory to the Sponsor, in an amount equal to that specified for the Contract bond, may be deposited with the Sponsor in lieu of such Contract bond and shall be subject to all the conditions of such bond and to such agreements as may be required by the Sponsor.

### **FAILURE TO EXECUTE CONTRACT**

Failure of the Contractor to execute the Contract and file acceptable bonds within ten (10) calendar days after he/she has received the Contract form shall be just cause for the annulment of the award, and for the forfeiture of the proposal guaranty. The proposal guaranty shall become the property of the Sponsor, not as a penalty, but in liquidation of damages sustained. Award may then be made to the next lowest responsible bidder or the work may be readvertised and constructed under a new Contract or otherwise as the Sponsor may decide.

### **RESPONSIBILITY OF THE CONTRACTOR**

The Contractor will be held responsible for the execution of a satisfactory and complete price of work, in accordance with the true intent of the drawings and specifications. He shall provide, without extra charge, all incidental items required as a part of his work including layout and survey, even though not particularly specified or indicated. If he has good reason for objecting to the use of any material, appliance, or method of construction as shown or specified, then he shall report such objections to the Engineer, and if approved by the Engineer, shall obtain proper adjustment before the Contract is made, and then shall proceed with the work with the understanding that a satisfactory job will be required. The Contractor is solely responsible for site safety and adherence to OSHA regulations.

#### **General Scope of Work:**

- Removal of existing bridge structure;
- Installation of mat foundation and three-sided precast structure;
- Installation of stone plunge pool and stream realignment/grading work;
- Roadway replacement and waterline relocation;
- Installation of stormwater management facilities;
- Maintenance and protection of Traffic;
- And whatever incidental work and appurtenances that are necessary to completely and satisfactorily complete the project.

All work associated with the bridge removal and replacement shall be in accordance to New York State Department of Transportation specifications.

This work shall be done in accordance with these contract documents, technical specifications and plans, and as directed by the Owner's Representative.

## **AUTHORITY OF ENGINEER**

The Commissioner of Public Works will be represented by an Engineer-In-Charge who will observe the work done under the Contract on a full time basis throughout construction.

The Engineer-In-Charge shall inspect work performed, review materials to be used, and stop and reject work and materials found to be not in accordance with the plans and specifications. His/Her authority shall cover all phases of the work. In the event that questions should arise concerning the interpretation or changes of plans and specifications or to the acceptability of the work, the Contractor shall submit his/her questions, in writing, to the Engineer-In-Charge. These questions shall be forwarded to the Commissioner of Public Works along with the Engineer-In-Charge's recommendations.

The Engineer-In-Charge may place on the job other personnel who shall observe the work as his/her direct representatives. Their authority shall consist of observing the work under the Contract, rejecting any defective material used and temporarily suspending any work improperly performed. They will not have any authority to make changes or alterations in the plans and specifications, nor be permitted to act as foremen for the Contractor.

Any work done or materials used without scheduling suitable observation by the Engineer-In-Charge or his/her authorized representative may be ordered removed and replaced at the Contractor's expense.

## **SUBSTANTIAL COMPLETION AND FINAL ACCEPTANCE OF WORK**

When in the opinion of the Engineer, the Contractor has substantially completed the project or a specified area of a project so that the County can occupy or utilize the project for the use it was intended, the Engineer shall recommend to the Commissioner of Public Works to issue a Certificate of Substantial Completion (See form on page 361).

When in the opinion of the Engineer the Contractor has fully performed the work under the Contract, the Engineer shall recommend to the Commissioner of Public Works the acceptance of the work so completed. If the Commissioner of Public Works accepts the recommendation of the Engineer, then he shall notify the Contractor by letter of such acceptance, and copies of such acceptance shall be sent to other interested parties.

## **CONTRACTOR'S PERSONNEL**

The Contractor shall place in charge of the work a competent and reliable English speaking superintendent, who shall have the authority to act for the Contractor and who shall be acceptable to the Engineer. This superintendent must be present at all times during the working day to receive directions and orders given by the Engineer or his/her representatives. All workers must have sufficient skill and experience to properly perform the work assigned to them. Any person employed by the Contractor who the Engineer may deem incompetent or unfit to perform the work shall at once be discharged and shall not again be employed on projects for the Sponsor at that specific task.

## **MATERIAL CERTIFICATES OF ACCEPTABILITY**

All certificates of acceptability of materials required by the specifications shall be supplied by the Contractor at no expense to the Sponsor. The Engineer shall have the right to approve of the laboratories or fabricators which will issue the certificates.



The cost of the inspection by the Engineer of any plants not approved by the New York State Department of Transportation shall be borne by the Contractor. This shall include, but not be limited to, plants employed to provide mobile concrete and steel reinforcement.

### **SUBCONTRACTORS, MATERIALMEN AND LABORERS**

The Contractor shall furnish the Engineer, before final payment is authorized, an affidavit that all labor and material associated with the work in any way is paid for in full. The Contractor shall indemnify and hold the Sponsor and the Engineer harmless from any lien or claim which may be made or filed after such payment by any subcontractor, materialman or laborer in connection with work performed hereunder.

### **RESPONSIBILITY FOR DAMAGE CLAIMS**

The Contractor shall indemnify and save harmless the Sponsor, its officers, and employees and Stantec, from all suits, actions, or claims of any character brought because of any injuries or damage received or sustained by any person, persons, or property on account of the operations of the said Contractor; or on account of or in consequence of any neglect in safeguarding the work; or through use of unacceptable materials in constructing the work; or because of any act or omission, neglect, or misconduct of the Contractor; or because of any claims or amounts recovered from any infringements of patent, trademark, or copyright; or from any claims on amounts arising or recovered under the Workers' Compensation Act, or any other law, ordinance, order, or decree; and so much of the money due the Contractor under and by virtue of his/her Contract as shall be considered necessary by the Sponsor for such purpose, may be retained for the use of the Sponsor; or, in case no money is due, his/her surety may be held until such suit or suits, action or actions, claim or claims for injuries or damages as aforesaid shall have been settled and suitable evidence to that effect furnished to the Sponsor; except that money due the Contractor will not be withheld when the Contractor produces satisfactory evidence that he/she is adequately protected by public liability and property damage insurance.

The Contractor agrees to make no claim for damages for delay in the performance of this contract occasioned by any act or omission to act of the Sponsor or the Engineer, or any of its representatives, and the Contractor agrees that any such claim shall be fully compensated for by an extension of time to complete the performance of work as provided herein.

### **NO WAIVER OF LEGAL RIGHTS**

The Sponsor shall not be precluded or stopped by a measurement, estimate or certificate made either before or after the completion and acceptance of the work and payment therefore, from showing the true amount and character of the work performed and materials furnished by the Contractor, nor from showing that any such measurement, from recovering from the Contractor or his/her sureties, or both, such damage as it may sustain by reason of his/her failure to comply with the terms of the Contract. Neither the acceptance by the Sponsor, or any representative of the Sponsor, nor any extension of time, nor any possession taken by the Sponsor shall operate as a waiver of any portion of the Contract or of any power herein reserved, or of any right to damages. A waiver of any breach of the Contract shall not be held to be a waiver of any other or subsequent breach.

## **LITIGATION**

In the event any litigation shall arise from this contract, the laws of the State of New York shall control any litigation, regardless of which party shall institute such action.

## **NOTICE TO PROCEED**

The "Notice to Proceed" will stipulate the date on which it is expected the Contractor will begin the work. Commencement of work by the Contractor shall be deemed and taken as a waiver of this notice on his/her part. In no case, however, shall the Contractor begin work prior to the date of the signing of the Contract.

## **PROSECUTION OF WORK**

The Contractor shall start construction operations on the part of the project approved by the Engineer or set forth in the approved Progress Schedule. The work shall be conducted in such manner and with sufficient materials, equipment, and labor as are considered necessary to insure its completion in accordance with the plans and specifications as interpreted by the Engineer, by the date set forth in the Agreement. Should the prosecution of the work for any reason be discontinued, the Contractor shall notify the Engineer at least 24 hours in advance of resuming operations.

## **TEMPORARY SUSPENSION OF WORK**

The Engineer shall have the authority to suspend the work wholly or in part by written order for such period as he may deem necessary due to unsuitable weather, to conditions considered unfavorable for the suitable prosecution of the work, or to carry out orders given or to perform any provisions of the Contract.

## **DATE OF COMPLETION OF CONTRACT WORK**

The Contractor shall perform fully, entirely, and in a satisfactory and acceptable manner the work contracted, by the date stipulated in the Agreement.

In adjusting the Agreement date for the completion of the project, all strikes, lock-outs, unusual delays in transportation, or any condition over which the Contractor has no control, and also any suspensions ordered by the Engineer for causes not the fault of the Contractor, shall be excluded from the computation of the contract time for completion of the work. No allowance will be made for delays or suspensions of the prosecution of the work due to the fault of the Contractor.

## **TERMINATION OF CONTRACT**

If the Contractor is adjudged bankrupt or makes an assignment for the benefit of creditors or a receiver is appointed for the Contractor or any insolvency arrangement proceedings are instituted by or against him, or if the Contractor fails after seven (7) days notice to supply enough properly skilled workers or proper materials or fails to prosecute the work with such diligence as will insure its completion by the Agreement date or shall in any other respect commit a breach of his Agreement and fail to remedy the same within seven (7) days after notice thereof, then the County may, by twenty-four (24) hours written notice, terminate the Contractor's right to proceed with the balance of the work or with any portion thereof and may take possession of the work and complete it by Contract or otherwise. The County may utilize such materials, plant and equipment as may be on the site of the work.

## **ASSIGNMENT**

Assignment of the contract shall be in accordance with Section 109 of the General Municipal Law as follows:

### **§109. Assignment of public contracts**

1. A clause shall be inserted in all specifications or contracts hereafter made or awarded by any officer, board or agency of a political subdivision, or of any district therein, prohibiting any contractor, to whom any contract shall be let, granted or awarded, as required by law, from assigning, transferring, conveying, subletting or otherwise disposing of the same, or of his right, title, or interest therein, or his power to execute such contract, to any other person or corporation without the previous consent in writing of the officer, board or agency awarding the contract.
2. If any contractor, to whom any contract is let, granted or awarded, as required by law, by any officer, board or agency of a political subdivision, or of any district therein, shall without the previous written consent specified in subdivision one of this section, assign, transfer, convey, sublet or otherwise dispose of such contract, or his right, title, or interest therein, or his power to execute such contract, to any other person or corporation, the officer, board or agency which let, made, granted or awarded such contract shall revoke and annul such contract, and the political subdivision or district therein, as the case may be, and such officer, board or agency shall be relieved and discharged from any and all liability and obligations growing out of such contract to such contractor, and to the person or corporation to which such contract shall have been assigned, transferred, conveyed, sublet or otherwise disposed of, and such contractor, and his assignees, transferees or sublessees shall forfeit and lose all moneys theretofore earned under such contract, except so much as may be required to pay his employees. The provisions of this section shall not hinder, prevent, or affect an assignment

## **PAYMENTS ON CONTRACT**

Payments to the Contractor for work satisfactorily completed will be made monthly in the amount of the work completed. No monthly payment will be rendered for less than 10% of the Contract amount or \$10,000, whichever is less. The payments will be based on the completed percentage of each unit bid as shown in the Itemized schedule.

The attention of persons intending to make proposals is specifically called to the provisions of Section 70 and 71 of the Lien Law in relation to funds being received by a Contractor for a public improvement. These provisions declare that the funds received by the Contractor shall constitute trust funds in the hands of such Contractor to be applied first to the payment of certain claims.

No certificate approving or authorizing the first partial payment, or in the event taxes shall be found due in accordance with this Section after the first payment to the Contractor, then no certificates approving or authorizing any final payment shall be made to a foreign Contractor unless such Contractor furnishes satisfactory proof that all taxes due by such Contractor under the provisions of Articles 9, 9A, 16, and 16A of the Tax Law have been paid. The certificate of the State Tax Commission to the effect that all such taxes have been paid shall be conclusive proof of the payment of such taxes.

The term "Foreign Contractor" as used in the preceding paragraph means in the case of an individual, a person who is a legal resident of another state or foreign country; and in the case of

a firm or co-partnership, one having one or more partners who is a legal resident of another State or foreign country and in the case of a corporation, one having its principal place of business in another State or foreign country.

### **DIFFERING SITE CONDITIONS**

The Contractor shall promptly, and before the conditions are disturbed, give a written notice to the Engineer of (1) subsurface or latent physical conditions at the site which differ materially from those indicated in this contract, or (2) unknown physical conditions at the site of an unusual nature, which differ materially from those ordinarily encountered and generally recognized as inhering in work of the character provided for in the contract.

The Engineer shall investigate the site conditions promptly after receiving the notice. If the conditions do materially so differ and cause an increase or decrease in the Contractor's cost of, or the time required for, performing any part of the work under this contract, whether or not changed as a result of the conditions, then an equitable adjustment shall be made under this clause and the contract modified in writing accordingly. The Contractor shall not have rights to suspend work during resolution of a differing site condition as stipulated in Section 105-14 of the Standard Specifications.

No request by the Contractor for an equitable adjustment to the contract under this clause shall be allowed, unless the Contractor has given the written notice required; provided, that the time prescribed above for giving written notice may be extended by the Engineer.

### **OPERATIONAL DAMAGES**

The Contractor shall protect all trees and shrubs in an approved manner, which may include fences and boards lashed to trees to prevent damage from blasting or machine operations. He/She shall prevent damage to pipes, conduits and other underground structures and all land monuments and property marks.

The Contractor shall be responsible for all fires on the site of the work whether started by himself/herself or others and no materials shall be burned on the site except with the approval of the Engineer and not without first obtaining permits from the proper municipal authorities.

### **EXCAVATION**

The Contractor's attention is called to the fact that any contours shown in the plans are approximate, and in any event, they are not to be deemed or considered by the Contractor as a warranty or a representation by the Engineer of exact field conditions.

### **SITE SAFETY**

The Contractor shall perform all work in the Contract Documents in a workmanlike manner with due regard to the safety of the employees and of the public. The Contractor shall comply with all rules, regulations and standards of the Occupational Safety and Health Administration, and U.S. Department of Labor in the performance of the work required by the Contract Documents in all matters regarding the safety and protection of persons employed in construction, excavation and demolition work. The Contractor shall also meet all applicable requirements of the State of New York Department of Labor, Industrial Code Rule 53 regarding construction, excavation and demolition operations at or near underground facilities. The Contractor is fully and solely responsible for site safety precautions.

## **PRECONSTRUCTION CONFERENCE AND PROJECT SCHEDULE**

The Contractor will be represented at the preconstruction conference by those staff to be in responsible charge of the work, including the site superintendent.

## **SPECIALTY ITEMS IN THIS CONTRACT**

Item 606 Series	-	Guiderail
Item 610.16XX	-	Establishing Turf
Item 625.01	-	Survey Operations
Item 645 Series	-	Signs
Item 646 Series	-	Snow Plow Markers

## **REQUIRED NOTICES**

a. Fire and Police Officials

Local fire and police authorities shall be notified by the Contractor in advance of the beginning of the progress of the work in order to coordinate and maintain sufficient fire and police protection.

b. School Officials and Ambulance Companies

The Contractor shall closely coordinate all work impacting school pedestrian and bus traffic with the Engineer. Safe School Route Maintenance Plans shall be submitted by the Contractor and approved by the Engineer prior to construction. The cost of any additional signage, flag persons or other requirements to maintain school routes throughout the duration of the project shall be included in the Bid price for Item 619.01.

The Contractor is required to make personal contact with appropriate ambulance companies in respect to the effect of road closing on their operations. This should be done several weeks in advance of changes so that there will be adequate time for them to make necessary adjustments to their schedules and routes.

## **ENVIRONMENTAL CONCERNS**

The Sponsor has filed a joint application to the New York State Department of Environmental Conservation and the United States Army Corps of Engineers for a Protection of Waters, Article 15, Section 404 and Water Quality Certification, Section 401 Nationwide Permit.

The Contractor shall incorporate best management practices to control sediment and erosion, as defined in Section 107-12 – Water Quality Protection and Section 209 – Soil Erosion and Sediment Control of the Standard Specifications, and the project Stormwater Pollution Prevention Plan (SWPPP).

At any time the County or the Engineer feels work is adversely impacting adjacent properties, he/she shall order such operations be terminated, and the Contractor must provide the necessary mitigation devices prior to continuing.

## **PERFORMANCE GRADED (PG) BINDER AND MIX DESIGN LEVEL**

Requirements of this note apply to all Section 402 Asphalt (HMA) items in this contract.

### **PG BINDER**

Use a **PG 64S-22** (Standard) meeting the requirements of AASHTO M 332, *Standard Specification for Performance Graded Asphalt Binder using Multiple Stress Creep Recovery (MSCR)*, for the production of hot mix asphalt mixtures for this project. Terminal Blend Crumb Rubber modifier may be used for this PG binder.

When terminal blend CRM PG binder is used, the following shall apply:

- Crumb rubber particles shall be finer than #30 sieve size.
- The CRM PG binder shall be storage-stable and homogeneous.
- The Dynamic Shear Rheometer (DSR) shall be set at 2-mm gap.
- The CRM PG binder shall be 99% free of particles retained on the 600 µm sieve as tested in accordance with Section 5.4 of M 332.

Use of polyphosphoric acid (PPA) to modify the PG binder properties is prohibited for mixtures under this contract. This prohibition also applies to the use of PPA as a cross-linking agent for polymer modification.

### **MOISTURE SUSCEPTIBILITY TESTING**

Any HMA mix design where the primary aggregate component by weight is granite or crushed gravel will be subject to moisture susceptibility testing by the producer during design, unless this requirement is waived by the RME. TSR testing may be required by the RME when there is a change to the asphalt binder source.

Moisture susceptibility will be determined by calculating the tensile strength ratio (TSR) of each specimen according to AASHTO T 283, Resistance of Compacted Asphalt Mixtures to Moisture-Induced Damage, except as modified in Section V.D. of NYSDOT Materials Method 5.16.

If the TSR of the HMA gyratory specimens is less than 80%, as required in AASHTO M 323, corrective action is required. Corrective action to improve the moisture susceptibility of the HMA mixture can include the use of anti-strip additives or blending of other aggregate materials to reduce the proportion of granite or gravel aggregates in the mix. When corrective action is necessary, any changes made to the design must be noted on the JMF, and all other volumetric and mechanical properties must be evaluated for compliance with NYSDOT Materials Method 5.16 using a one-point design. The results must be reported to the RME prior to production.

### **MIX DESIGN**

The mixture designs must be developed in accordance with the criteria specified in the HMA items that are appropriate for an Estimated Traffic Level of < 30 Million ESALs.

**Note:** The PG binder for this project may be modified with CRM additives to meet the requirements stated above. Handling of the HMA shall be discussed at pre-construction and pre-paving meetings.

For 80 Series Compaction Method, complete all breakdown roller passes before the mat

temperature falls below 230° F, unless approved by the Engineer.

When the asphalt mixture is being placed over a Sheet-Applied Waterproofing Membrane, maintain a minimum delivery temperature in accordance with the Material Detail Sheets prepared by the membrane manufacturer.

### **BITUMINOUS SEALER**

All transverse and longitudinal joints between existing and new asphalt surfaces shall be sealed with a Bituminous Material meeting the material requirements of NYSDOT Materials Designation of Section 702-0700, Asphalt Filler. Cost to be included in the various asphalt items.

### **SHOP DRAWINGS**

The Contractor will be required to submit shop drawings for the following items:

- Precast Reinforced Concrete Span Units and Headwalls
- Precast Reinforced Concrete Wingwalls

### **ASBESTOS**

There are to be NO asbestos materials used in any work being done for the County. If it is found that products with asbestos materials have been used, the vendor using them will be held responsible for all cost of clean-up, removal and any other cost that may occur because of it.

### **REMOVAL OF COUNTY, TOWN OR VILLAGE-OWNED FACILITIES**

The Contractor shall give sufficient notice to the Engineer, for removal by Departmental Forces, of such County, Town or Village-owned facilities as signs and delineators.

### **EXISTING CONDITIONS**

All dimensions affected by the geometrics and/or location of existing facilities are to be checked in the field by the Contractor, before ordering or fabricating any materials, and before any construction begins. It shall be the responsibility of the Contractor to supply the Engineer with all field dimensions required to check shop drawings.

### **ENGINEER'S FIELD OFFICE – INTERNET SERVICE**

The Contractor shall be responsible for providing a Business Class internet connection with a minimum download speed of 15 Mbps and a minimum upload speed of 5 Mbps. The internet connection shall include a local area network that can either be a wired connection with a minimum of 4 x 10Base-T/100Base-TX – RJ-45 connections with min. Cat5e cables or a wireless connection (min. 802.11n) for at least two (2) people. The cost of providing a Business Class internet connection and all necessary equipment and wiring for the local area network shall be included in the price bid for Item 637.11, Engineer's Field Office – Type 1.

## **OFFICE TECHNOLOGY AND SUPPLIES**

Item 637.34, Office Technologies and Supplies, will be used to pay for any office related supplies such as copy paper, copier toner, etc., not included under Item 637.11, Engineer's Field Office – Type 1. The Contractor shall receive approval from the Engineer in Charge prior to the purchase of **ANY** Office Technology and Supplies and requests for reimbursement.

## **HOLIDAYS**

Work shall be prohibited on days recognized by Cattaraugus County as legal holidays. The following days shall be treated as legal holidays:

<b>CATTARAUGUS COUNTY LEGAL HOLIDAYS</b>	
New Year's Day	January 1 <sup>st</sup>
Martin Luther King, Jr. Day	3 <sup>rd</sup> Monday in January
Presidents' Day	3 <sup>rd</sup> Monday in February
Memorial Day	Last Monday in May
Independence Day	July 4 <sup>th</sup>
Labor Day	1 <sup>st</sup> Monday in September
Columbus Day	2 <sup>nd</sup> Monday in October
Election Day	
Veteran's Day	November 12 <sup>th</sup> (Observed 2018)
Thanksgiving Day	4 <sup>th</sup> Thursday in November
Christmas Day	December 25 <sup>th</sup>



**US CUSTOMARY ASPHALT PRICE ADJUSTMENT**

<b>ASPHALT PRICE ADJUSTMENT<sup>1</sup> CONVERSION FACTORS</b>		
<b>MATERIAL DESCRIPTION</b>	<b>CONVERSION FACTOR</b>	<b>ITEM NUMBER<sup>2</sup></b>
Bituminous Stabilized Course	0.065 t PGB/yd <sup>3</sup>	302.01
Asphalt Treated Permeable Base, Type 1	0.030 t PGB/t	402.010902
Asphalt Treated Permeable Base, Type 2	0.035 t PGB/t	402.011902
Shim Course	0.0825 t PGB/t	402.058902
6.3 SUPERPAVE HMA	0.067 t PGB/t	402.068xxxx8 RR
9.5 SUPERPAVE HMA	0.062 t PGB/t	402.09xxxx
12.5 SUPERPAVE HMA	0.055 t PGB/t	402.12xxxx
19 SUPERPAVE HMA	0.049 t PGB/t	402.19xxxx
25 SUPERPAVE HMA	0.045 t PGB/t	402.25xxxx
37.5 SUPERPAVE HMA	0.040 t PGB/t	402.37xxxx
Paved Placed Surface Treatment, Types A, B, and C	0.064 t PGB/t	415.01xxyy03
Micro-Surfacing, Quick-Set Slurry	0.078 t PGB/t	410.102102 RR, 410.103102 RR, 410.104102 RR, 410.202302 RR, 410.203302 RR
Straight Tack Coat	0.0026 t PGB/gal	407.0103
Asphaltic Sealants (ASTM 6690)	0.0027 t PGB/gal	402.75xx RR, 402.76xx RR, 402.76020018
Chip Seal	0.0027 t PGB/gal	410.0105006, 410.07
Asphalt Emulsion for Cold Recycling	0.0027 t PGB/gal	416.02xx
Fog Seal and Dilute Tack Coat	0.0016 t PGB/gal	407.0102, 416.04, 410.0106006
PG Binder for Cold Recycling	0.0043 t PGB/gal	416.03
Asphaltic Sealant – Clean & Seal	0.225 t PGB/LNMI	402.76030008, 412.76030001
Asphaltic Sealant – Treating Cracks	0.240 t PGB/LNMI	412.76040001
Asphaltic Sealant – Rout & Seal	0.270 t PGB/LNMI	402.76010008, 412.76040001
Repair of HMA Pavement, Temporary Asphalt	See Note 4	633.14, 633.15, 633.16, 619.06xx
True and Leveling, Asphalt Sidewalks, Driveways, Bike Paths, Gutters	See Note 5	402.017902, 402.01890xxx, 608.020102, 624.02xx

### ASPHALT PRICE ADJUSTMENT<sup>1</sup> CONVERSION FACTORS

**Notes:**

1. In accordance with Standard Specification §698-3.01, the index value for the asphalt price adjustment is the average posted price of Performance Graded Binder (PGB) for the month of bid letting.
2. Item Number - This is the contract pay item number under which these materials are most frequently paid. Unless indicated otherwise, materials similar to those indicated under the column entitled "Material Description" are also eligible for adjustment using the factor listed for a similar material with the same pay units regardless of the actual contract pay item number.
3. Quality Adjustment Items (402/608/624) are not eligible for asphalt price adjustment.
4. Asphalt Price Adjustment Conversion Factor based on units of TONS of asphalt placed, not the pay units of this item. The conversion factor for HMA Pavement Repair and Temporary Asphalt will be based on the actual asphalt mixture used.
5. The conversion factor for Truing and Leveling, Driveways, and other items that allow asphalt mix options, will be based on the actual mixtures used.
6. A two digit suffix (RR) at the end of a contract pay item indicates a special specification.
7. The conversion factors for HMA mixed with slag shall be increased by 25%.
8. t = tons

### US CUSTOMARY FUEL PRICE ADJUSTMENT

#### FUEL PRICE ADJUSTMENT<sup>1</sup> CONVERSION FACTORS

MATERIAL DESCRIPTION	CONVERSION FACTOR	ITEM NUMBER <sup>2</sup>
Unclassified Excavation	0.35 gal/yd <sup>3</sup>	203.02
Embankment	0.10 gal/yd <sup>3</sup>	203.03, 620.xx
Fill	0.45 gal/yd <sup>3</sup>	203.05, 203.06, 203.07, 203.08xx, 203.20, 203.21, 203.25
Controlled Low Strength Material	1.00 gal/yd <sup>3</sup>	204.01, 204.02, 204.03, 204.04
Trench/Culvert/Structure Excavation	0.50 gal/yd <sup>3</sup>	206.01, 206.0201
Bituminous Stabilized Course	1.40 gal/yd <sup>3</sup>	302.01, 307.01
Sub-base Course	1.00 gal/yd <sup>3</sup>	304 Items
Hot Mix Asphalt	2.50 gal/ton	402 Items <sup>3</sup> , 405.01, 608.020102 <sup>3</sup> , 619.0601 <sup>4</sup> , 624.02xxxx <sup>3,4</sup> , 633.14 <sup>3,4</sup> , 633.15 <sup>3,4</sup> , 633.16 <sup>3,4</sup>
Milling	0.10 gal/yd <sup>2</sup>	490 Items
Portland Cement Concrete Pavement	1.00 gal/yd <sup>3</sup>	502 Items <sup>3</sup> , 503.1010, 503.1011, 503.1012
Fill Type Retaining Walls	0.45 gal/yd <sup>3</sup>	554.30xx <sup>5</sup> , 554.31 <sup>5</sup> , 554.4x <sup>5</sup>
Footing Concrete & Concrete for Structures - All classes	1.00 gal/yd <sup>3</sup>	555 Items, 582.05

<b>FUEL PRICE ADJUSTMENT<sup>1</sup> CONVERSION FACTORS</b>		
<b>MATERIAL DESCRIPTION</b>	<b>CONVERSION FACTOR</b>	<b>ITEM NUMBER<sup>2</sup></b>
Approach Slabs	0.33 gal/yd <sup>2</sup>	557.2001, 557.2002, 557.2003, 557.2009, 557.22
Structural Slabs with bottom formwork	0.25 gal/yd <sup>2</sup>	557.01xx, 557.07, 557.30
Structural Slabs - no bottom formwork	0.15 gal/yd <sup>2</sup>	557.05xx, 557.09
Class D Concrete	0.05 gal/yd <sup>2</sup>	557.13, 584 Items
Concrete Barrier, Type A	0.16 gal/ft	606.3001, 606.3021, 606.3031
Concrete Barrier, Type B	0.19 gal/ft	569.01, 606.3002, 606.3022, 606.3032
Concrete Barrier, Type C	0.22 gal/ft	606.3003, 606.3023, 606.3033
Concrete Barrier, Half Section	0.11 gal/ft	569.02, 606.3004, 606.3024, 606.3034
Concrete Median Barrier, Single Slope	0.23 gal/ft	569.05, 606.3041, 606.3043, 606.3044
Concrete Median Barrier Wide, Single Slope	0.28 gal/ft	606.3051, 606.3053, 606.3054
Concrete Barrier Half Single Slope	0.17 gal/ft	569.04, 606.3061, 606.3063, 606.3064
Vertical Faced Concrete Parapet	0.10 gal/ft	569.03
Gravel, Stone, Slag	1.00 gal/yd <sup>3</sup>	411.01, 411.02, 411.03, 623.1x
Concrete Sidewalks and Driveways	1.00 gal/yd <sup>3</sup>	608.01xx
Topsoil	0.45 gal/yd <sup>3</sup>	610.10, 610.11xx, 610.14xx
<b>Notes:</b>		
<ol style="list-style-type: none"> <li>1. In accordance with Standard Specification §698-3.02, the index value for the fuel price adjustment is the posted price for the month of bid letting.</li> <li>2. Item Number - This is the contract pay item number under which these materials are most frequently paid. Unless indicated otherwise, materials similar to those indicated under the column entitled "Material Description" are also eligible for adjustment using the factor listed for a similar material with the same pay units regardless of the actual contract pay item number.</li> <li>3. Quality Adjustment Items (402/502/608/624) are not eligible for fuel price adjustment.</li> <li>4. Fuel Price Adjustment Conversion Factor based on units of TONS of asphalt placed, not the pay units of this item.</li> <li>5. Fuel Price Adjustment Conversion Factor based on units of CY of backfill paid under this item, not the pay units of this item.</li> </ol>		

## **STEEL PRICE ADJUSTMENT**

The following items/materials permanently incorporated into the work are eligible for steel and iron price adjustment:

- Structural Steel
- Reinforcing Steel (in superstructures or substructures)
- Shear Studs
- Open Steel Bridge Floor
- Tension Strands
- Dowel Bars
- Load Transfer Devices
- Steel in Precast or Prestressed Concrete Items, Including:
  - Drainage Structures and Manholes
  - Box Culverts
  - Prefabricated Bridge and Wall Elements
  - Concrete Barrier
- Bridge, Culvert and Guide Railing
- Sheet Piling and Cofferdams
- Piling
- Utility Frames, Grates & Covers
- Overhead Sign Structures
- Ductile Iron Water Main and Ductile Iron Appurtenances
- Steel Water Main
- Poles (Signal, Power, etc.)

Steel and iron price adjustments will be calculated in accordance with Section 698 Price Adjustments. Eligible materials include major components of items for which the weight of the steel and/or iron can be simply determined from manufacturer's/supplier's data or shipping weights, and exclude minor appurtenances individually weighing less than 2 kg (i.e. nuts, bolts, washers, etc.). Eligible precast or prestressed concrete items shall have total reinforcing steel weight listed on the approved shop drawings. The Engineer will determine the mass of eligible materials from the following sources, in declining order of precedence; approved shop drawings, contract documents, industry standards (i.e. Steel Manual, AWWA Standards, etc.) and manufacturer's data.



**This Page Left Intentionally Blank**

## **ITEM 203.24010017 - SHOULDER BACKUP MATERIAL**

### **DESCRIPTION:**

This work shall consist of furnishing, placing, grading, compacting, and trimming shoulder backup material of the type indicated adjacent to shoulders to the lines, grades, and locations indicated in the contract documents or to the lines, grades, and locations directed by the Engineer, in accordance with these specifications and details shown in the plans.

### **MATERIALS:**

**General.** Except as indicated below, §304-2 shall apply. Where the term “subbase course” is used in that subsection, “shoulder backup material” shall replace it.

Material incorporated into the work need not be stockpiled. The State may test for plasticity, soundness, and gradation at its discretion, or may decide not to test for these properties. Materials incorporated into the work shall consist of uncontaminated materials, free of glass, conforming with these specifications, the contract documents, and the directions of the Engineer.

Unless indicated otherwise in the contract documents, the Contractor may choose the type or types of material to use from the list of types given below. Intermixing of the permitted types, however, will be subject to the approval of the Engineer.

Material that proves to be, or that is determined by the Engineer to be impractical to place, grade, trim or compact as shown in the contract documents or as directed by the Engineer shall not be used.

**Type A (Crusher-run, crushed gravel, or crushed stone.)** Shoulder backup material of this type shall consist of well graded crusher-run material from a stone quarry or gravel source, or crushed Portland cement concrete. The material shall contain no organic, deleterious, hazardous or toxic material. Gradation shall be subject to the approval of the Engineer, but no material larger than 1 inch in greatest dimension will be allowed. Materials shall not show losses greater than 20% after four cycles of the Magnesium Sulfate Soundness test.

**Type B (Subbase Course, Type 2.)** Shoulder backup material of this type shall meet the material requirements of Subbase Course, Type 2. The Regional Geotechnical Engineer will examine each proposed source of material for compliance with these specification requirements, and submit an evaluation of the material including any limiting conditions to the Engineer.

**Type C (Subbase Course, Type 4.)** Shoulder backup material of this type shall meet the material requirements of Subbase Course, Type 4 of the Standard Specifications, except the material furnished shall consist of sand and gravel or a blend of sand and gravel and stone. The Regional Geotechnical Engineer will examine each proposed source of material for compliance with these specification requirements, and submit an evaluation of the material including any limiting conditions to the Engineer.

**Type D (Recycled Asphalt Concrete.)** Material provided under this option shall consist of uncontaminated recycled asphalt concrete pavement produced on the contract or from other sources as approved by the Engineer. Recycled asphalt concrete pavement shall be substantially free of pieces larger than 4 inches.

**Type E (Select Structural or Granular Fill.)** Material provided under this option shall consist of material conforming to the soundness, gradation, and pH requirements for Select Structural Fill or Select Granular Fill, except top size shall not exceed that for Type C.

## **ITEM 203.24010017 - SHOULDER BACKUP MATERIAL**

### **CONSTRUCTION DETAILS:**

The material shall be placed on the grade in a manner to minimize segregation using equipment and procedures approved by the Engineer. Uncontrolled spreading from piles dumped on the grade resulting

in segregation will not be permitted. Maximum loose lift thickness prior to compaction shall be 6 inches. The contractor's compaction methods and equipment shall be approved by the Engineer. After compaction, the finished surface of the compacted material at the shoulder edge shall not extend above the edge of the shoulder nor be more than 0.4 inches below the shoulder. Tolerance elsewhere shall be 1½ inch, except the surface shall be graded to drain at every location.

If the final grade of the material is not in reasonable close conformity to the lines and grades indicated in the contract documents, or to those directed by the Engineer, the material shall be trimmed to achieve reasonably close conformance. Additional material shall be brought in to fill deficiencies, and excess material (trimmings) shall be removed. Trimmings may be incorporated into the shoulder backup work at other locations along the project if such opportunities exist and provided gradation of the resulting material remains in conformance with the gradation requirement for the selected option. When it is not possible to incorporate the trimmings in the shoulder backup work the trimmings shall be disposed of or used elsewhere in the contract in a manner approved by the Engineer.

### **METHOD OF MEASUREMENT:**

Shoulder Backup Material will be measured for payment as the number of tons evidenced by delivery tickets, properly placed, graded, compacted, and trimmed along the edge of shoulder in accordance with these specifications and the directions of the Engineer.

When truck scales are not available within reasonable distance of the source of the material, as determined by the Engineer, the quantity paid for will be determined using conversion factors and the loose volume of shoulder backup material determined by measuring the dump truck bodies. The Contractor shall select the trucks to be used for delivery of the material with the approval of the Engineer. Once the trucks are selected and approved by the Engineer, no other trucks shall be used for delivery of this material. The trucks shall be uniformly loaded to the satisfaction of the Engineer.

Additional material brought in as part of the trimming operation to fill deficiencies will be measured for payment. The quantity of trimmings removed from the shoulder backup operation and not incorporated into the shoulder backup work elsewhere, however, will not be measured for payment under this pay item, and the Engineer will make an appropriate adjustment to the measured quantity.

Unless other conversion factors are indicated in the Contract Documents, the conversion factor will be 0.05tons per cubic foot, loose measure.

### **BASIS OF PAYMENT:**

The unit price bid per ton for Shoulder Backup Material shall include the cost of all labor, materials, and equipment necessary to satisfactorily furnish, place, grade, compact, and trim Shoulder Backup Material.



**ITEM 208.01030022                      BIORETENTION AND DRY SWALE SOIL**  
**ITEM 208.01040022                      LABORATORY TESTING FOR SOIL PHOSPHORUS**  
**CONCENTRATION**

**DESCRIPTION**

This work shall consist of installing Bioretention and Dry Swale Soil in accordance with the contract documents and as directed by the Engineer.

The work shall also consist of having the Bioretention and Dry Swale Soil tested for total soil phosphorus concentration at a qualified laboratory. A qualified laboratory shall be defined as a laboratory that is certified by the New York State Department of Health (NYSDOH) Environmental Laboratory Approval Program (ELAP) to test soil for total soil phosphorus.

**MATERIALS**

The following sections of the standard specifications apply:

§703-07                                      Concrete Sand  
§713-01                                      Topsoil, Type A (see exceptions below)

The soil for Bioretention areas and Dry Swales shall be a uniform mix, free of stones, stumps, roots or other objects larger than two inches (2”) in diameter. The Bioretention and Dry Swale soil shall be visibly free of noxious weeds.

Bioretention and Dry Swale Soil shall be a well blended mixture of three (3) parts sand and one (1) part topsoil, by volume. The Bioretention and Dry Swale Soil shall have a pH range of 5.2 to 7.6, and an organic content of 3-7%.

Sand shall meet the requirements of §703-07 *Concrete Sand*.

Topsoil shall be in accordance with the requirements of §713-01 *Topsoil* for Topsoil Type A, except as follows:

- All topsoil shall be sampled and tested, regardless of the source.
- Sampling of topsoil, amended topsoil, and the Bioretention and Dry Swale Soil shall be done by the Contractor/Supplier. Sampling protocol shall be in accordance with §713-01 *Topsoil*.

Soil amendments to increase organic content shall be peat moss. Peat moss shall be commercially produced and shall be composed of the partly decomposed stems and leaves of any or several species of sphagnum moss. It shall be free from wood, decomposed colloidal residue, and other foreign matter. It shall have a pH range between 3.5 pH - 5.5 pH as determined in accordance with the Association of Official Agricultural Chemists’ testing methods. It’s water-absorbing ability shall be a minimum of 1100% by weight on an oven-dry basis.

Acceptance of Bioretention and Dry Swale soil will be based upon a material certification that the

**ITEM 208.01030022**                      **BIORETENTION AND DRY SWALE SOIL**  
**ITEM 208.01040022**                      **LABORATORY TESTING FOR SOIL PHOSPHORUS**  
**CONCENTRATION**

material conforms to the above requirements. The Contractor/Supplier shall provide to the Engineer copies of testing results of the sand gradation, topsoil gradation, organic content percentage of the Bioretention and Dry Swale Soil, and pH of the Bioretention and Dry Swale Soil. These tests are to be paid under the Bioretention and Dry Swale Soil item.

The Contractor shall provide to the Engineer copies of testing results for Soil Phosphorus Concentration. Samples to be submitted to the qualified laboratory shall be obtained in accordance with §713-01 *Topsoil*. Sampling shall be paid under the pay item for Bioretention and Dry Swale Soil. The results of the Soil Phosphorus analysis shall not be used as the basis for material acceptance.

Sampling frequency for total phosphorous shall be one composite sample for the first 100 to 500 cubic yards of soil, and an additional composite sample for each additional 500 cubic yards, or portion thereof. No samples are required for stockpiles of less than 100 cubic yards.

**CONSTRUCTION DETAILS**

Bioretention and Dry Swale Soil shall be installed at the locations and to the depth(s) as shown in the contract documents. Placement of Bioretention and Dry Swale Soil shall be done in lifts of 12 inches to 18 inches. The soil shall be loosely compacted, such as by tamping lightly with a dozer or backhoe bucket. No other materials or substances shall be mixed or dumped within the Bioretention area and Dry Swale that may be harmful to plant growth, or prove a hindrance to planting or maintenance operations.

**METHOD OF MEASUREMENT**

**Bioretention and Dry Swale Soil**

The work will be measured as the number of cubic yards of Bioretention and Dry Swale Soil installed, computed from payment lines shown in the contract documents.

**Laboratory Testing for Soil Phosphorus Concentration**

The work will be measured by the number of soil samples analyzed for Soil Phosphorus Concentration by a qualified laboratory.

**BASIS OF PAYMENT**

The unit price bid for a cubic yard of Bioretention and Dry Swale Soil shall include the cost of furnishing all labor, materials, and equipment necessary to satisfactorily complete the work, including costs for testing.

The unit price bid for Laboratory Testing for Soil Phosphorus Concentration, shall include the receipted costs of testing, including the cost of the laboratory test(s) and all labor, materials and equipment required to obtain and deliver soil sample(s) to the qualified laboratory plus 5% for profit

**ITEM 208.01030022      BIORETENTION AND DRY SWALE SOIL**  
**ITEM 208.01040022      LABORATORY TESTING FOR SOIL PHOSPHORUS**  
**CONCENTRATION**

and overhead.

## **ITEM 595.98200018 – SPRAY-APPLIED WATERPROOFING MEMBRANE**

### **DESCRIPTION**

The contractor shall furnish and install a spray-applied, waterproofing membrane in accordance with the contract documents, approved Material Detail Sheets (MDS), and as directed by the Engineer. All surface preparation and quality-control testing of substrates and the applied membrane are included.

### **MATERIALS**

The spray-applied, waterproofing membrane shall meet the requirements of §717-02 and *ASTM C1305/C1305M - 16 Crack Bridging Ability of Liquid-Applied Waterproofing Membrane*.

### **CONSTRUCTION DETAILS**

**General.** The contractor shall arrange for the membrane manufacturer to have a competent technical representative with necessary equipment to perform the quality-control testing at the job site during all phases of preparation and installation. The technical representative shall present all quality-control testing equipment to the Engineer to verify calibration dates and demonstrate their competency to perform quality-control testing.

The contractor shall submit Safety Data Sheets (SDS) and approved MDS prepared by the membrane manufacturer to the Engineer a minimum of two weeks prior to the scheduled commencement of work. The contractor shall protect personnel exposed to primers and membranes in accordance with SDS and store all components of the membrane, including broadcast aggregates, at the job site in accordance with approved MDS.

The contractor shall use tarpaulin or other suitable masking to protect traffic, the surrounding environment and adjacent features from over spraying.

### **Membrane Application and Quality-Control Testing.**

**Substrate Preparation.** All surfaces that are to receive the membrane shall be prepared in accordance with the approved (MDS). The contractor shall blast clean all surfaces as a minimum and remove residual matter using brooms and oil/moisture-free compressed air.

**Substrate Moisture Content and Temperature.** The contractor shall measure the surface moisture content ( $\leq 5\%$  reading is required using a moisture meter) and temperature before applying the primer and membrane. The surface moisture content and temperature shall be within allowable tolerances as stated in the approved MDS. The contractor shall perform one test for every two thousand square feet of area as specified in the contract documents or a minimum of three tests.

**Substrate Cohesion/Primer Adhesion.** After the substrate has been prepared, the contractor shall test the cohesion of the substrate and the adhesion of the primer to the substrate in accordance with *ASTM D4541 – Pull-Off Strength of Coatings Using Portable Adhesion Testers*. The contractor shall conduct tests after the primer has sufficiently cured as determined by the technical representative. One test shall be performed for every two thousand square feet of prepared substrate area and at locations where deficient adhesion is suspected by the Engineer or a minimum of three tests. Required minimum adhesion strengths shall be 300 psi for each test on steel or 150 psi on Portland Cement Concrete substrates before applying primer to the remaining surface area.

**Primer Application.** The contractor shall apply primer to the substrate surface area at a rate specified in the approved MDS.

**Membrane Application.** The contractor shall apply each course of the membrane at a rate specified in the approved MDS. The membrane shall be applied in one or two coats to a minimum total thickness of 80 mils.

## **ITEM 595.98200018 – SPRAY-APPLIED WATERPROOFING MEMBRANE**

Membrane Thickness. The contractor shall measure the wet-film thickness of each course of membrane using a standard comb-type thickness gauge or measure the dry-film thickness of each course of membrane using a dry-film thickness gauge for nonferrous substrates.

One measurement for every one hundred square feet of membrane shall be done. The measured thickness of each course of the membrane and the entire thickness of the finished membrane shall be greater than or equal to 80 mils.

Membrane Pin Holes. Following the application and cure of the primer and membrane, the membrane shall be visually inspected for pinholes and integrity. Any defects shall be repaired as per the manufacturer recommendation.

Membrane Adhesion. The contractor shall test the adhesion of the membrane to the substrate in accordance with *ASTM D4541 – Pull-Off Strength of Coatings Using Portable Adhesion Testers*. One test shall be conducted for every two thousand square feet of membrane applied, and at locations where deficient adhesion is suspected by the Engineer or a minimum of three tests. The minimum adhesion strengths shall be 300 psi for each test on steel or 150 psi on Portland Cement Concrete substrates.

The contractor shall repair and correct any deficiencies in the membrane and substrate noted during quality-control testing as recommended by the manufacturer's representative at no additional cost to the State.

Binder Aggregate Application. When cold-applied, wearing-surface overlays are specified, or additional shear resistance between the membrane and the wearing surface is desirable, the contractor shall broadcast an aggregate binder onto the membrane in accordance with the approved MDS.

The aggregate binder shall be applied to the membrane before the membrane cures and as specified in the approved MDS. The aggregate and membrane shall be fully integrated after the aggregate has been applied and the membrane has cured. Loose aggregate shall be removed with brooms or oil/moisture-free compressed air before applying the tack coat.

Tack Coat Application. The contractor shall apply a tack coat to the finished membrane as specified in the MDS prior to overlaying the membrane with a wearing surface.

### **METHOD OF MEASUREMENT**

This work will be measured as the number of square feet of spray-applied, waterproofing membrane satisfactorily furnished and installed as shown on the contract plans or ordered by the Engineer.

### **BASIS OF PAYMENT**

The unit price bid shall include the cost of furnishing all labor, materials, and equipment necessary to satisfactorily complete the work.

**ITEM 603.98100402 - SMOOTH INTERIOR PERFORATED CORRUGATED  
POLYETHYLENE UNDERDRAIN PIPE - 4 INCH**  
**ITEM 603.98100602 - SMOOTH INTERIOR PERFORATED CORRUGATED  
POLYETHYLENE UNDERDRAIN PIPE - 6 INCH**

**DESCRIPTION**

The work shall consist of furnishing and installing Smooth Interior Perforated Corrugated Polyethylene Underdrain Pipe for drainage in accordance with this specification, the contract plans and Standard Sheet entitled "Installation Details For Corrugated Metal and Structural Plate Pipe and Pipe-Arches".

**MATERIALS**

The Smooth Interior Perforated Corrugated Polyethylene Underdrain Pipe shall conform to the requirements of Subsection 706-12, Smooth Interior Corrugated Polyethylene Pipe, of the Standard Specifications. Underdrain filter materials shall consist of screened gravel, crushed stone, crushed gravel, or crushed slag meeting the requirements of Section 605-2.02 Granular Filter Materials.

**End Sections.** End sections shall be galvanized steel conforming to Subsection 707-10, Galvanized Steel End Sections, of the Standard Specifications. Metal end sections used with polyethylene pipe shall be sized as follows:

- 4 inch pipe: No standard galvanized steel end sections available
- 6 inch pipe: PE Pipe I.D. 6 inch, Wall Thickness 1/2 inch, O.D. 7 inch

Material shall be supplied by a supplier from the approved list.

**CONSTRUCTION DETAILS**

The construction details of §605 shall apply.

In addition:

**Excavation.** The requirements specified in §206, Trench, Culvert and Structure Excavation, that apply to culverts and storm drains shall govern, except as modified herein. Width of excavation at trench bottom shall be measured as the nominal outside diameter of the pipe plus 12 inch (for 6 inch pipe) or 8 inch (for 4 inch pipe) or as shown on the plans.

**Laying Pipe.** All pipe shall be laid in reasonably close conformity to line and grade and shall have a full, firm and even bearing at each joint and along the entire length of pipe. Joint misalignment shall not result in offsets, in the interior smooth liner, greater than 1/4 inch. Pipe laying shall begin at the downstream end and progress upstream or as ordered by the Engineer. Any single run of pipe, excluding end sections, shall consist wholly of the same type material unless otherwise directed by the Engineer. In a closed drainage application, the upgrade end of a run need not be capped. End caps shall be used when deemed necessary by the Engineer.

**Handling and Assembly of Pipe.** All pipe shall be handled, stored and assembled in accordance with the Approved Materials Details except as modified on the plans or by the Engineer's written order. Two copies of Materials Details shall be provided by the supplier through the Contractor to the Engineer at

**ITEM 603.98100402 - SMOOTH INTERIOR PERFORATED CORRUGATED  
POLYETHYLENE UNDERDRAIN PIPE - 4 INCH**  
**ITEM 603.98100602 - SMOOTH INTERIOR PERFORATED CORRUGATED  
POLYETHYLENE UNDERDRAIN PIPE - 6 INCH**

least 10 days prior to shipment of the product to the job site. Joint assembly shall be made with manufactured ends. Field cuts shall be permitted only at the terminal ends and shall result in a minimum pipe length of 3 feet. Joint assemblies shall provide separations no greater than 1/2 inch between adjoining sections of pipe. Lateral connections shall be made with appropriate fittings, supplied by the pipe manufacturer and approved by the Engineer. For basin connections, installations shall be in accordance with the standard sheet entitled "Drainage Structure Details" except that the pipe end shall protrude 2 inches into the basin interior to provide for a 45° battered grout seal. The battered grout seal shall be applied to both interior and exterior faces of the basin.

**Bedding and Backfilling Pipe.** When using Smooth Interior Perforated Corrugated Polyethylene Underdrain pipe, the type of materials to be used in bedding and backfilling shall conform to the provisions of Section 605, Underdrains. Installation shall be in accordance with the Standard Sheet titled "Installation Details for Corrugated Metal and Structural Plate Pipe and Pipe-Arches" and as modified in this specification. The pipe after installation shall have a maximum deflection of 5% of its nominal inside diameter. The Engineer may order the Contractor to perform mandrel testing to determine the 5% specification compliance.

**Damage.** Pipe that is damaged or disturbed through any cause occurring prior to acceptance of the contract, shall be replaced or realigned as directed by the Engineer at the Contractor's expense. Pipe that is defective from any cause, including damage caused by handling, will be unacceptable for installation and will be replaced as directed by the Engineer at no cost to the State. Pipe with damaged ends may be incorporated into the work at terminal locations and only if the damaged portion is totally removed by the field cut. Repair or replacement of pipe that is disturbed, damaged, or misaligned shall provide the same product as a new pipe installation, as determined by the Engineer.

**METHOD OF MEASUREMENT**

The provisions of §605-4 Method of Measurement shall apply.

**BASIS OF PAYMENT**

End sections, excavation, granular fill and backfill will be paid for separately under their appropriate items in §203 and §206 as applicable.

Payment will be made under:

- Item 603.98100402 M Smooth Interior Perforated Corrugated Polyethylene Underdrain Pipe, 4 inch Diameter
- Item 603.98100602 M Smooth Interior Perforated Corrugated Polyethylene Underdrain Pipe, 6 inch Diameter

**ITEM 620.30010001 - ROCK OR CROSS VANES**

**DESCRIPTION**

This work shall consist of installing Rock Vanes or Cross Vanes in accordance with the contract documents and as directed by the Engineer.

**MATERIALS**

Rock Vanes and Cross Vanes shall be constructed of stone meeting the requirements of §620-2.01 of the Standard Specifications. Consideration should be given to obtaining stone that is similar in color and texture to the native stone in the project area. Unless otherwise specified on the plans, stone used for the construction of Rock Vanes and Cross Vanes shall be shaped as nearly as practicable in the form of right rectangular prisms. Unless there is a table on the plans specifying stone sizes for individual rock or cross vanes, stones shall meet the following size requirements:

	<b>A-axis</b>	<b>B-axis</b>	<b>C-axis</b>
<b>Minimum Size</b>	4 ft.	3 ft.	2 ft.
<b>Maximum Size</b>	8 ft.	6 ft.	5 ft.

**CONSTRUCTION DETAILS**

A Cross Vane, if specified, shall consist of two Rock Vanes on either side of the stream, the upstream ends of which are joined by a sill constructed in the stream channel. Details of sill construction apply only to Cross Vanes.

Rock Vanes shall be constructed so that adjoining rocks slope down, in an upstream direction, from the stream bank full elevation to the stream invert. The Rock Vane is typically set at an angle of 20-30 degrees to the stream bank, with the upstream end located approximately one third the channel width from the stream bank. The downstream end of the Rock Vane shall be keyed into the stream bank a minimum of 8 feet. The upstream end of the Rock Vane is keyed into the stream bed at the design invert elevation of the stream bed.

Cross Vanes and Rock Vanes are comprised of two layers of rock: footer rocks and vane rocks. Footer rocks shall be the same size or larger than the vane rocks which rest on them, and shall be set to provide a stable base for the vane rocks. Consideration shall be given to the available sizes of footer and vane rocks to ensure the vane rocks shall have a smooth finished grade. To ensure proper placement, the Contractor shall have an excavator of a suitable size, and containing a thumb, or other equipment acceptable to the Engineer, capable of carefully placing rocks at precise locations. The contractor shall check all voids between rocks such that no voids greater than 4 inches in size will be present.



## **ITEM 620.30010001 - ROCK OR CROSS VANES**

Sills shall be constructed similarly to the upstream ends of the Rock Vanes. Sills are typically set perpendicular to the flow of the stream, and are approximately one third the channel width in length. The footer rocks and vane rocks shall be keyed into the stream bed, with the finished grade of the sill at the design invert of the proposed stream bed.

Vane rocks shall be placed in a linear fashion so as to produce a smooth finished grade for the Rock Vane or Cross Vane, and shall be placed so as to minimize void spaces between the adjacent rocks. The spaces between vane rocks, and between the vane rocks and footer rocks, shall be filled with spalls of suitable size.

Excavation and backfill necessary to complete the construction of Rock or Cross Vanes is included in the Rock or Cross Vane items, and shall meet the requirements of Section 206 of the Standard Specifications. All unsuitable and surplus rocks will be removed from the site. Excavation of scour pools on the downstream sides of the Rock or Cross Vanes is not included in these items, and shall be paid for under the appropriate trench and culvert excavation item.

### **METHOD OF MEASUREMENT**

The quantity of Rock or Cross Vanes shall be the number of cubic yards computed from the payment lines shown on the plans, or as directed by the Engineer.

### **BASIS OF PAYMENT**

The unit price bid shall include the cost of furnishing all labor, materials, and equipment necessary to satisfactorily complete the work, and shall include all incidental work necessary to the construction, including, but not limited to: excavation, de-watering, backfill and disposal of excess and unsuitable materials.

## **ITEM 627.50140008 - CUTTING PAVEMENT**

### **DESCRIPTION:**

The contractor shall cut existing asphalt pavement, concrete pavement, asphalt surface course, or asphalt concrete overlay on concrete pavement at the locations indicated and detailed on the plans and as directed by the Engineer.

### **MATERIALS:**

None specified.

### **CONSTRUCTION DETAILS:**

Existing pavement and overlay shall be cut perpendicular to the roadway surface along neat lines, and to the depth indicated on the plans and typical sections, using appropriate equipment. After the pavement has been cut through, the Contractor may use pry bars, pneumatic tools or other methods, to pry loose the pavement to be removed from the pavement that is to remain. A pavement breaker may be used to break up the pavement to be removed after the pavement has been completely cut through and completely free from the pavement to remain.

When pavement cutting is called for in the Contract documents, if a neat vertical face with minimal shatter is obtained by performing an adjacent operation (such as milling) which eliminates the need to perform a separate pavement cutting operation, payment will be made for both the pavement cutting item and the item for the adjacent operation.

Any existing pavements and curbs not indicated to be removed that are damaged by the contractor's operations, shall be repaired at no additional cost to the State. Pavement cutting that the contractor chooses to do for his/her own convenience shall not receive any additional payment from the State.

### **METHOD OF MEASUREMENT:**

The quantity to be measured will be the number of linear feet of pavement cutting satisfactorily completed.

### **BASIS OF PAYMENT:**

The unit price bid per linear foot of pavement cutting shall include the cost of all labor, materials, and equipment necessary to satisfactorily complete the work.

Payment for prying, breaking, removal and disposal of cut pavement shall be made through other appropriate items.



**This Page Left Intentionally Blank**

## **SPECIAL NOTE STATE PREVAILING WAGE RATES**

The Contractor shall ensure that workers are paid the appropriate wages and supplemental (fringe) benefits. Throughout the contract, the Contractor shall obtain and pay workers in accordance with periodic wage rate schedule updates from the NYS Department of Labor (NYSDOL). Wage rate amendments and supplements are available on the NYSDOL web site at [www.labor.state.ny.us](http://www.labor.state.ny.us). All changes line or clarification of labor classification(s) and applicability of prevailing wage rates shall be obtained in writing from the Office of the Director, NYSDOL Bureau of Public Work.

The NYSDOL prevailing wage rate schedule for this contract has been determined and is available on the internet. The prevailing wage rate schedule is accessed by visiting the NYSDOL web site, navigating to the appropriate web page, and entering the Prevailing Rate Case No. (PRC#). The PRC# is provided on NYSDOL Form PW-200 included in this contract proposal.

A copy of the project specific prevailing wage rate schedule will be provided to the successful bidder upon award of the contract. Upon written request, the schedule will be provided by the Cattaraugus County Department of Public Works to prospective bidders without internet access.

**NEW YORK STATE DEPARTMENT  
OF LABOR (NYS DOL)  
PREVAILING WAGE RATES**



Andrew M. Cuomo, Governor

Roberta Reardon, Commissioner

Cattaraugus County DPW

Dan Clark  
Stantec  
61 Commercial Street  
Suite 100  
Rochester NY 14614

Schedule Year 2019 through 2020  
Date Requested 12/07/2018  
PRC# 2018014342

Location New Albion, Cattaraugus County  
Project ID#  
Project Type Removal of existing bridge and replacement with a new three sided structure

### PREVAILING WAGE SCHEDULE FOR ARTICLE 8 PUBLIC WORK PROJECT

Attached is the current schedule(s) of the prevailing wage rates and prevailing hourly supplements for the project referenced above. A unique Prevailing Wage Case Number (PRC#) has been assigned to the schedule(s) for your project.

The schedule is effective from July 2019 through June 2020. All updates, corrections, posted on the 1st business day of each month, and future copies of the annual determination are available on the Department's website [www.labor.ny.gov](http://www.labor.ny.gov). Updated PDF copies of your schedule can be accessed by entering your assigned PRC# at the proper location on the website.

It is the responsibility of the contracting agency or its agent to annex and make part, the attached schedule, to the specifications for this project, when it is advertised for bids and /or to forward said schedules to the successful bidder(s), immediately upon receipt, in order to insure the proper payment of wages.

Please refer to the "General Provisions of Laws Covering Workers on Public Work Contracts" provided with this schedule, for the specific details relating to other responsibilities of the Department of Jurisdiction.

Upon completion or cancellation of this project, enter the required information and mail **OR** fax this form to the office shown at the bottom of this notice, **OR** fill out the electronic version via the NYSDOL website.

#### NOTICE OF COMPLETION / CANCELLATION OF PROJECT

Date Completed: \_\_\_\_\_ Date Cancelled: \_\_\_\_\_

Name & Title of Representative: \_\_\_\_\_

Phone: (518) 457-5589 Fax: (518) 485-1870  
W. Averell Harriman State Office Campus, Bldg. 12, Room 130, Albany, NY 12240

# General Provisions of Laws Covering Workers on Article 8 Public Work Contracts

## Introduction

The Labor Law requires public work contractors and subcontractors to pay laborers, workers, or mechanics employed in the performance of a public work contract not less than the prevailing rate of wage and supplements (fringe benefits) in the locality where the work is performed.

## Responsibilities of the Department of Jurisdiction

A Department of Jurisdiction (Contracting Agency) includes a state department, agency, board or commission; a county, city, town or village; a school district, board of education or board of cooperative educational services; a sewer, water, fire, improvement and other district corporation; a public benefit corporation; and a public authority awarding a public work contract.

The Department of Jurisdiction (Contracting Agency) awarding a public work contract MUST obtain a Prevailing Rate Schedule listing the hourly rates of wages and supplements due the workers to be employed on a public work project. This schedule may be obtained by completing and forwarding a "Request for wage and Supplement Information" form (PW 39) to the Bureau of Public Work. The Prevailing Rate Schedule MUST be included in the specifications for the contract to be awarded and is deemed part of the public work contract.

Upon the awarding of the contract, the law requires that the Department of Jurisdiction (Contracting Agency) furnish the following information to the Bureau: the name and address of the contractor, the date the contract was let and the approximate dollar value of the contract. To facilitate compliance with this provision of the Labor Law, a copy of the Department's "Notice of Contract Award" form (PW 16) is provided with the original Prevailing Rate Schedule.

The Department of Jurisdiction (Contracting Agency) is required to notify the Bureau of the completion or cancellation of any public work project. The Department's PW 200 form is provided for that purpose.

Both the PW 16 and PW 200 forms are available for completion [online](#).

## Hours

No laborer, worker, or mechanic in the employ of a contractor or subcontractor engaged in the performance of any public work project shall be permitted to work more than eight hours in any day or more than five days in any week, except in cases of extraordinary emergency. The contractor and the Department of Jurisdiction (Contracting Agency) may apply to the Bureau of Public Work for a dispensation permitting workers to work additional hours or days per week on a particular public work project.

There are very few exceptions to this rule. Complete information regarding these exceptions is available on the "[4 Day / 10 Hour Work Schedule](#)" form (PW 30.1).

## Wages and Supplements

The wages and supplements to be paid and/or provided to laborers, workers, and mechanics employed on a public work project shall be not less than those listed in the current Prevailing Rate Schedule for the locality where the work is performed. If a prime contractor on a public work project has not been provided with a Prevailing Rate Schedule, the contractor must notify the Department of Jurisdiction (Contracting Agency) who in turn must request an original Prevailing Rate Schedule form the Bureau of Public Work. Requests may be submitted by: mail to NYSDOL, Bureau of Public Work, State Office Bldg. Campus, Bldg. 12, Rm. 130, Albany, NY 12240; Fax to Bureau of Public Work (518) 485-1870; or electronically at the NYSDOL website [www.labor.ny.gov](http://www.labor.ny.gov).

Upon receiving the original schedule, the Department of Jurisdiction (Contracting Agency) is REQUIRED to provide complete copies to all prime contractors who in turn MUST, by law, provide copies of all applicable county schedules to each subcontractor and obtain from each subcontractor, an affidavit certifying such schedules were received. If the original schedule expired, the contractor may obtain a copy of the new annual determination from the NYSDOL website [www.labor.ny.gov](http://www.labor.ny.gov).

The Commissioner of Labor makes an annual determination of the prevailing rates. This determination is in effect from July 1st through June 30th of the following year. The annual determination is available on the NYSDOL website [www.labor.ny.gov](http://www.labor.ny.gov).

## Payrolls and Payroll Records

Every contractor and subcontractor MUST keep original payrolls or transcripts subscribed and affirmed as true under penalty of perjury. Payrolls must be maintained for at least three (3) years from the project's date of completion. At a minimum, payrolls must show the following information for each person employed on a public work project: Name, Address, Last 4 Digits of Social Security Number, Classification(s) in which the worker was employed, Hourly wage rate(s) paid, Supplements paid or provided, and Daily and weekly number of hours worked in each classification.



The filing of payrolls to the Department of Jurisdiction is a condition of payment. Every contractor and subcontractor shall submit to the Department of Jurisdiction (Contracting Agency), within thirty (30) days after issuance of its first payroll and every thirty (30) days thereafter, a transcript of the original payrolls, subscribed and affirmed as true under penalty of perjury. The Department of Jurisdiction (Contracting Agency) shall collect, review for facial validity, and maintain such payrolls.

In addition, the Commissioner of Labor may require contractors to furnish, with ten (10) days of a request, payroll records sworn to as their validity and accuracy for public work and private work. Payroll records include, but are not limited to time cards, work description sheets, proof that supplements were provided, cancelled payroll checks and payrolls. Failure to provide the requested information within the allotted ten (10) days will result in the withholding of up to 25% of the contract, not to exceed \$100,000.00. If the contractor or subcontractor does not maintain a place of business in New York State and the amount of the contract exceeds \$25,000.00, payroll records and certifications must be kept on the project worksite.

The prime contractor is responsible for any underpayments of prevailing wages or supplements by any subcontractor.

All contractors or their subcontractors shall provide to their subcontractors a copy of the Prevailing Rate Schedule specified in the public work contract as well as any subsequently issued schedules. A failure to provide these schedules by a contractor or subcontractor is a violation of Article 8, Section 220-a of the Labor Law.

All subcontractors engaged by a public work project contractor or its subcontractor, upon receipt of the original schedule and any subsequently issued schedules, shall provide to such contractor a verified statement attesting that the subcontractor has received the Prevailing Rate Schedule and will pay or provide the applicable rates of wages and supplements specified therein. (See NYS Labor Laws, Article 8 . Section 220-a).

### **Determination of Prevailing Wage and Supplement Rate Updates Applicable to All Counties**

The wages and supplements contained in the annual determination become effective July 1st whether or not the new determination has been received by a given contractor. Care should be taken to review the rates for obvious errors. Any corrections should be brought to the Department's attention immediately. It is the responsibility of the public work contractor to use the proper rates. If there is a question on the proper classification to be used, please call the district office located nearest the project. Any errors in the annual determination will be corrected and posted to the NYSDOL website on the first business day of each month. Contractors are responsible for paying these updated rates as well, retroactive to July 1st.

When you review the schedule for a particular occupation, your attention should be directed to the dates above the column of rates. These are the dates for which a given set of rates is effective. To the extent possible, the Department posts rates in its possession that cover periods of time beyond the July 1st to June 30th time frame covered by a particular annual determination. Rates that extend beyond that instant time period are informational ONLY and may be updated in future annual determinations that actually cover the then appropriate July 1st to June 30th time period.

### **Withholding of Payments**

When a complaint is filed with the Commissioner of Labor alleging the failure of a contractor or subcontractor to pay or provide the prevailing wages or supplements, or when the Commissioner of Labor believes that unpaid wages or supplements may be due, payments on the public work contract shall be withheld from the prime contractor in a sufficient amount to satisfy the alleged unpaid wages and supplements, including interest and civil penalty, pending a final determination.

When the Bureau of Public Work finds that a contractor or subcontractor on a public work project failed to pay or provide the requisite prevailing wages or supplements, the Bureau is authorized by Sections 220-b and 235.2 of the Labor Law to so notify the financial officer of the Department of Jurisdiction (Contracting Agency) that awarded the public work contract. Such officer MUST then withhold or cause to be withheld from any payment due the prime contractor on account of such contract the amount indicated by the Bureau as sufficient to satisfy the unpaid wages and supplements, including interest and any civil penalty that may be assessed by the Commissioner of Labor. The withholding continues until there is a final determination of the underpayment by the Commissioner of Labor or by the court in the event a legal proceeding is instituted for review of the determination of the Commissioner of Labor.

The Department of Jurisdiction (Contracting Agency) shall comply with this order of the Commissioner of Labor or of the court with respect to the release of the funds so withheld.

### **Summary of Notice Posting Requirements**

The current Prevailing Rate Schedule must be posted in a prominent and accessible place on the site of the public work project. The prevailing wage schedule must be encased in, or constructed of, materials capable of withstanding adverse weather conditions and be titled "PREVAILING RATE OF WAGES" in letters no smaller than two (2) inches by two (2) inches.

The "Public Work Project" notice must be posted at the beginning of the performance of every public work contract, on each job site.

Every employer providing workers. compensation insurance and disability benefits must post notices of such coverage in the format prescribed by the Workers. Compensation Board in a conspicuous place on the jobsite.

Every employer subject to the NYS Human Rights Law must conspicuously post at its offices, places of employment, or employment training centers, notices furnished by the State Division of Human Rights.

Employers liable for contributions under the Unemployment Insurance Law must conspicuously post on the jobsite notices furnished by the NYS Department of Labor.

## **Apprentices**

Employees cannot be paid apprentice rates unless they are individually registered in a program registered with the NYS Commissioner of Labor. The allowable ratio of apprentices to journeyworkers in any craft classification can be no greater than the statewide building trade ratios promulgated by the Department of Labor and included with the Prevailing Rate Schedule. An employee listed on a payroll as an apprentice who is not registered as above or is performing work outside the classification of work for which the apprentice is indentured, must be paid the prevailing journeyworker's wage rate for the classification of work the employee is actually performing.

NYSDOL Labor Law, Article 8, Section 220-3, require that only apprentices individually registered with the NYS Department of Labor may be paid apprenticeship rates on a public work project. No other Federal or State Agency of office registers apprentices in New York State.

Persons wishing to verify the apprentice registration of any person must do so in writing by mail, to the NYSDOL Office of Employability Development / Apprenticeship Training, State Office Bldg. Campus, Bldg. 12, Albany, NY 12240 or by Fax to NYSDOL Apprenticeship Training (518) 457-7154. All requests for verification must include the name and social security number of the person for whom the information is requested.

The only conclusive proof of individual apprentice registration is written verification from the NYSDOL Apprenticeship Training Albany Central office. Neither Federal nor State Apprenticeship Training offices outside of Albany can provide conclusive registration information.

It should be noted that the existence of a registered apprenticeship program is not conclusive proof that any person is registered in that program. Furthermore, the existence or possession of wallet cards, identification cards, or copies of state forms is not conclusive proof of the registration of any person as an apprentice.

## **Interest and Penalties**

In the event that an underpayment of wages and/or supplements is found:

- Interest shall be assessed at the rate then in effect as prescribed by the Superintendent of Banks pursuant to section 14-a of the Banking Law, per annum from the date of underpayment to the date restitution is made.
- A Civil Penalty may also be assessed, not to exceed 25% of the total of wages, supplements, and interest due.

## **Debarment**

Any contractor or subcontractor and/or its successor shall be ineligible to submit a bid on or be awarded any public work contract or subcontract with any state, municipal corporation or public body for a period of five (5) years when:

- Two (2) willful determinations have been rendered against that contractor or subcontractor and/or its successor within any consecutive six (6) year period.
- There is any willful determination that involves the falsification of payroll records or the kickback of wages or supplements.

## **Criminal Sanctions**

Willful violations of the Prevailing Wage Law (Article 8 of the Labor Law) may be a felony punishable by fine or imprisonment of up to 15 years, or both.

## **Discrimination**

No employee or applicant for employment may be discriminated against on account of age, race, creed, color, national origin, sex, disability or marital status.

No contractor, subcontractor nor any person acting on its behalf, shall by reason of race, creed, color, disability, sex or national origin discriminate against any citizen of the State of New York who is qualified and available to perform the work to which the employment relates (NYS Labor Law, Article 8, Section 220-e(a)).

No contractor, subcontractor, nor any person acting on its behalf, shall in any manner, discriminate against or intimidate any employee on account of race, creed, color, disability, sex, or national origin (NYS Labor Law, Article 8, Section 220-

e(b) ).

The Human Rights Law also prohibits discrimination in employment because of age, marital status, or religion.

There may be deducted from the amount payable to the contractor under the contract a penalty of \$50.00 for each calendar day during which such person was discriminated against or intimidated in violation of the provision of the contract (NYS Labor Law, Article 8, Section 220-e(c) ).

The contract may be cancelled or terminated by the State or municipality. All monies due or to become due thereunder may be forfeited for a second or any subsequent violation of the terms or conditions of the anti-discrimination sections of the contract (NYS Labor Law, Article 8, Section 220-e(d) ).

Every employer subject to the New York State Human Rights Law must conspicuously post at its offices, places of employment, or employment training centers notices furnished by the State Division of Human Rights.

### **Workers' Compensation**

In accordance with Section 142 of the State Finance Law, the contractor shall maintain coverage during the life of the contract for the benefit of such employees as required by the provisions of the New York State Workers' Compensation Law.

A contractor who is awarded a public work contract must provide proof of workers' compensation coverage prior to being allowed to begin work.

The insurance policy must be issued by a company authorized to provide workers' compensation coverage in New York State. Proof of coverage must be on form C-105.2 (Certificate of Workers' Compensation Insurance) and must name this agency as a certificate holder.

If New York State coverage is added to an existing out-of-state policy, it can only be added to a policy from a company authorized to write workers' compensation coverage in this state. The coverage must be listed under item 3A of the information page.

The contractor must maintain proof that subcontractors doing work covered under this contract secured and maintained a workers' compensation policy for all employees working in New York State.

Every employer providing worker's compensation insurance and disability benefits must post notices of such coverage in the format prescribed by the Workers' Compensation Board in a conspicuous place on the jobsite.

### **Unemployment Insurance**

Employers liable for contributions under the Unemployment Insurance Law must conspicuously post on the jobsite notices furnished by the New York State Department of Labor.



Andrew M. Cuomo, Governor

Roberta Reardon, Commissioner

Cattaraugus County DPW

Dan Clark  
Stantec  
61 Commercial Street  
Suite 100  
Rochester NY 14614

Schedule Year 2019 through 2020  
Date Requested 12/07/2018  
PRC# 2018014342

Location New Albion, Cattaraugus County  
Project ID#  
Project Type Removal of existing bridge and replacement with a new three sided structure

### Notice of Contract Award

New York State Labor Law, Article 8, Section 220.3a requires that certain information regarding the awarding of public work contracts, be furnished to the Commissioner of Labor. One "Notice of Contract Award" (PW 16, which may be photocopied), **MUST** be completed for **EACH** prime contractor on the above referenced project.

Upon notifying the successful bidder(s) of this contract, enter the required information and mail **OR** fax this form to the office shown at the bottom of this notice, **OR** fill out the electronic version via the NYSDOL website.

### Contractor Information

All information must be supplied

Federal Employer Identification Number: _____		
Name: _____		
Address: _____ _____		
City: _____	State: _____	Zip: _____
Amount of Contract: \$ _____	Contract Type:	
Approximate Starting Date: ____/____/____	<input type="checkbox"/> (01) General Construction	
Approximate Completion Date: ____/____/____	<input type="checkbox"/> (02) Heating/Ventilation	
	<input type="checkbox"/> (03) Electrical	
	<input type="checkbox"/> (04) Plumbing	
	<input type="checkbox"/> (05) Other : _____	

Phone: (518) 457-5589 Fax: (518) 485-1870  
W. Averell Harriman State Office Campus, Bldg. 12, Room 130, Albany, NY 12240

# IMPORTANT NOTICE

FOR

## CONTRACTORS & CONTRACTING AGENCIES

### Social Security Numbers on Certified Payrolls

The Department of Labor is cognizant of the concerns of the potential for misuse or inadvertent disclosure of social security numbers. Identity theft is a growing problem and we are sympathetic to contractors' concerns with regard to inclusion of this information on payrolls if another identifier will suffice.

For these reasons, *the substitution of the use of the last four digits of the social security number on certified payrolls submitted to contracting agencies on public work projects is now acceptable to the Department of Labor.*

**NOTE:** This change does not affect the Department's ability to request and receive the entire social security number from employers during the course of its public work / prevailing wage investigations.

**To all State Departments, Agency Heads and Public Benefit Corporations  
IMPORTANT NOTICE REGARDING PUBLIC WORK ENFORCEMENT FUND**

## **Budget Policy & Reporting Manual**

# **B-610**

### **Public Work Enforcement Fund**

*effective date December 7, 2005*

---

#### **1. Purpose and Scope:**

This Item describes the Public Work Enforcement Fund (the Fund, PWEF) and its relevance to State agencies and public benefit corporations engaged in construction or reconstruction contracts, maintenance and repair, and announces the recently-enacted increase to the percentage of the dollar value of such contracts that must be deposited into the Fund. This item also describes the roles of the following entities with respect to the Fund:

- New York State Department of Labor (DOL),
- The Office of the State of Comptroller (OSC), and
- State agencies and public benefit corporations.

#### **2. Background and Statutory References:**

DOL uses the Fund to enforce the State's Labor Law as it relates to contracts for construction or reconstruction, maintenance and repair, as defined in subdivision two of Section 220 of the Labor Law. State agencies and public benefit corporations participating in such contracts are required to make payments to the Fund.

Chapter 511 of the Laws of 1995 (as amended by Chapter 513 of the Laws of 1997, Chapter 655 of the Laws of 1999, Chapter 376 of the Laws of 2003 and Chapter 407 of the Laws of 2005) established the Fund.

#### **3. Procedures and Agency Responsibilities:**

The Fund is supported by transfers and deposits based on the value of contracts for construction and reconstruction, maintenance and repair, as defined in subdivision two of Section 220 of the Labor Law, into which all State agencies and public benefit corporations enter.

Chapter 407 of the Laws of 2005 increased the amount required to be provided to this fund to .10 of one-percent of the total cost of each such contract, to be calculated at the time agencies or public benefit corporations enter into a new contract or if a contract is amended. The provisions of this bill became effective August 2, 2005.

**To all State Departments, Agency Heads and Public Benefit Corporations  
IMPORTANT NOTICE REGARDING PUBLIC WORK ENFORCEMENT FUND**

OSC will report to DOL on all construction-related ("D") contracts approved during the month, including contract amendments, and then DOL will bill agencies the appropriate assessment monthly. An agency may then make a determination if any of the billed contracts are exempt and so note on the bill submitted back to DOL. For any instance where an agency is unsure if a contract is or is not exempt, they can call the Bureau of Public Work at the number noted below for a determination. Payment by check or journal voucher is due to DOL within thirty days from the date of the billing. DOL will verify the amounts and forward them to OSC for processing.

For those contracts which are not approved or administered by the Comptroller, monthly reports and payments for deposit into the Public Work Enforcement Fund must be provided to the Administrative Finance Bureau at the DOL within 30 days of the end of each month or on a payment schedule mutually agreed upon with DOL.

Reports should contain the following information:

- Name and billing address of State agency or public benefit corporation;
- State agency or public benefit corporation contact and phone number;
- Name and address of contractor receiving the award;
- Contract number and effective dates;
- Contract amount and PWEF assessment charge (if contract amount has been amended, reflect increase or decrease to original contract and the adjustment in the PWEF charge); and
- Brief description of the work to be performed under each contract.

Checks and Journal Vouchers, payable to the "New York State Department of Labor" should be sent to:

Department of Labor  
Administrative Finance Bureau-PWEF Unit  
Building 12, Room 464  
State Office Campus  
Albany, NY 12240

Any questions regarding billing should be directed to NYSDOL's Administrative Finance Bureau-PWEF Unit at (518) 457-3624 and any questions regarding Public Work Contracts should be directed to the Bureau of Public Work at (518) 457-5589.

# Construction Industry Fair Play Act

## Required Posting For Labor Law Article 25-B § 861-d

Construction industry employers must post the "Construction Industry Fair Play Act" notice in a prominent and accessible place on the job site.

Failure to post the notice can result in penalties of up to \$1,500 for a first offense and up to \$5,000 for a second offense.

The posting is included as part of this wage schedule. Additional copies may be obtained from the NYS DOL website, [www.labor.ny.gov](http://www.labor.ny.gov).

If you have any questions concerning the Fair Play Act, please call the State Labor Department toll-free at 1-866-435-1499 or email us at: [dol.misclassified@labor.state.ny.us](mailto:dol.misclassified@labor.state.ny.us) .





New York State Department of Labor  
Required Notice under Article 25-B of the Labor Law

**ATTENTION ALL EMPLOYEES, CONTRACTORS AND SUBCONTRACTORS:  
YOU ARE COVERED BY THE  
CONSTRUCTION INDUSTRY FAIR PLAY ACT**

The law says that you are an employee unless:

- You are free from direction and control in performing your job AND
- You perform work that is not part of the usual work done by the business that hired you AND
- You have an independently established business

Your employer cannot consider you to be an independent contractor unless all three of these facts apply to your work.

**IT IS AGAINST THE LAW FOR AN EMPLOYER TO MISCLASSIFY EMPLOYEES AS  
INDEPENDENT CONTRACTORS OR PAY EMPLOYEES OFF-THE-BOOKS.**

**Employee rights.** If you are an employee:

- You are entitled to state and federal worker protections such as
  - unemployment benefits, if unemployed through no fault of your own, able to work, and otherwise qualified
  - workers' compensation benefits for on-the-job injuries
  - payment for wages earned, minimum wage, and overtime (under certain conditions)
  - prevailing wages on public work projects
  - the provisions of the National Labor Relations Act and
  - a safe work environment
- It is a violation of this law for employers to retaliate against anyone who asserts their rights under the law. Retaliation subjects an employer to civil penalties, a private lawsuit or both.

**Independent Contractors:** If you are an independent contractor:

- You must pay all taxes required by New York State and Federal Law.

**Penalties** for paying off-the-books or improperly treating employees as independent contractors:

- **Civil Penalty**                      First Offense: up to \$2,500 per employee.  
    Subsequent Offense(s): up to \$5,000 per employee.
- **Criminal Penalty**                First Offense: Misdemeanor - up to 30 days in jail, up to a \$25,000 fine and debarment from performing Public Work for up to one year.  
    Subsequent Offense(s): Misdemeanor - up to 60 days in jail, up to a \$50,000 fine and debarment from performing Public Work for up to 5 years.

If you have questions about your employment status or believe that your employer may have violated your rights and you want to file a complaint, call the Department of Labor at 1(866)435-1499 or send an email to [dol.misclassified@labor.ny.gov](mailto:dol.misclassified@labor.ny.gov). All complaints of fraud and violations are taken seriously and you can remain anonymous.

**Employer Name:**

IA 999 (09/10)

# WORKER NOTIFICATION

(Labor Law §220, paragraph a of subdivision 3-a)

*Effective February 24, 2008*

This provision is an addition to the existing prevailing wage rate law, Labor Law §220, paragraph a of subdivision 3-a. It requires contractors and subcontractors to provide written notice to all laborers, workers or mechanics of the *prevailing wage rate* for their particular job classification *on each pay stub*\*. It also requires contractors and subcontractors to *post a notice* at the beginning of the performance of every public work contract *on each job site* that includes the telephone number and address for the Department of Labor and a statement informing laborers, workers or mechanics of their right to contact the Department of Labor if he/she is not receiving the proper prevailing rate of wages and/or supplements for his/her particular job classification. The required notification will be provided with each wage schedule, may be downloaded from our website [www.labor.ny.gov](http://www.labor.ny.gov) or made available upon request by contacting the Bureau of Public Work at 518-457-5589.

\* In the event that the required information will not fit on the pay stub, an accompanying sheet or attachment of the information will suffice.

# Attention Employees

## THIS IS A: **PUBLIC WORK PROJECT**

If you are employed on this project as a **worker, laborer, or mechanic** you are entitled to receive the **prevailing wage and supplements rate** for the classification at which you are working.

Chapter 629 of the Labor Laws of 2007:

**These wages are set by law and must be posted at the work site. They can also be found at:**  
[www.labor.ny.gov](http://www.labor.ny.gov)

If you feel that you have not received proper wages or benefits, please call our nearest office.\*

Albany	(518) 457-2744	Patchogue	(631) 687-4882
Binghamton	(607) 721-8005	Rochester	(585) 258-4505
Buffalo	(716) 847-7159	Syracuse	(315) 428-4056
Garden City	(516) 228-3915	Utica	(315) 793-2314
New York City	(212) 932-2419	White Plains	(914) 997-9507
Newburgh	(845) 568-5156		

\* For New York City government agency construction projects, please contact the Office of the NYC Comptroller at (212) 669-4443, or [www.comptroller.nyc.gov](http://www.comptroller.nyc.gov) – click on Bureau of Labor Law.

Contractor Name: \_\_\_\_\_

Project Location: \_\_\_\_\_

# **OSHA 10-hour Construction Safety and Health Course – S1537-A**

*Effective July 18, 2008*

This provision is an addition to the existing prevailing wage rate law, Labor Law §220, section 220-h. It requires that on all public work projects of at least \$250,000.00, all laborers, workers and mechanics working on the site, be certified as having successfully completed the OSHA 10-hour construction safety and health course. It further requires that the advertised bids and contracts for every public work contract of at least \$250,000.00, contain a provision of this requirement.

***NOTE: The OSHA 10 Legislation only applies to workers on a public work project that are required, under Article 8, to receive the prevailing wage.***

## Where to find OSHA 10-hour Construction Course

1. NYS Department of Labor website for scheduled outreach training at:

[https://labor.ny.gov/workerprotection/safetyhealth/dosh\\_training.shtm](https://labor.ny.gov/workerprotection/safetyhealth/dosh_training.shtm)

2. OSHA Training Institute Education Centers:

### **Rochester Institute of Technology OSHA Education Center**

Rochester, NY

Donna Winter

Fax (585) 475-6292

e-mail: [dlwtpo@rit.edu](mailto:dlwtpo@rit.edu)

(866) 385-7470 Ext. 2919

[www.rit.edu/~outreach/course.php3?CourseID=54](http://www.rit.edu/~outreach/course.php3?CourseID=54)

### **Atlantic OSHA Training Center**

UMDNJ – School of Public Health

Piscataway, NJ

Janet Crooks

Fax (732) 235-9460

e-mail: [crooksje@umdnj.edu](mailto:crooksje@umdnj.edu)

(732) 235-9455

<https://ophp.umdnj.edu/wconnect/ShowSchedule.awp?~~GROUP~AOTCON~10~>

### **Atlantic OSHA Training Center**

University at Buffalo

Buffalo, New York

Joe Syracuse

Fax (716) 829-2806

e-mail: [mailto:japs@buffalo.edu](mailto:mailto:japs@buffalo.edu)

(716) 829-2125

[http://www.smbs.buffalo.edu/CENTERS/trc/schedule\\_OSHA.php](http://www.smbs.buffalo.edu/CENTERS/trc/schedule_OSHA.php)

### **Keene State College**

Manchester, NH

Leslie Singleton

e-mail: [lsingletin@keene.edu](mailto:lsingletin@keene.edu)

(800) 449-6742

[www.keene.edu/courses/print/courses\\_osa.cfm](http://www.keene.edu/courses/print/courses_osa.cfm)

3. List of trainers and training schedules for OSHA outreach training at:

[www.OutreachTrainers.org](http://www.OutreachTrainers.org)

## Requirements for OSHA 10 Compliance

Chapter 282 of the Laws of 2007, codified as Labor Law 220-h took effect on July 18, 2008. The statute provides as follows:

The advertised specifications for every contract for public work of \$250,000.00 or more must contain a provision requiring that every worker employed in the performance of a public work contract shall be certified as having completed an OSHA 10 safety training course. The clear intent of this provision is to require that all employees of public work contractors, required to be paid prevailing rates, receive such training “prior to the performing any work on the project.”

The Bureau will enforce the statute as follows:

All contractors and sub contractors must attach a copy of proof of completion of the OSHA 10 course to the first certified payroll submitted to the contracting agency and on each succeeding payroll where any new or additional employee is first listed.

Proof of completion may include but is not limited to:

- Copies of bona fide course completion card (*Note: Completion cards do not have an expiration date.*)
- Training roster, attendance record of other documentation from the certified trainer pending the issuance of the card.
- Other valid proof

\*\*A certification by the employer attesting that all employees have completed such a course is not sufficient proof that the course has been completed.

Any questions regarding this statute may be directed to the New York State Department of Labor, Bureau of Public Work at 518-485-5696.

# WICKS Reform 2008

(For all contracts advertised or solicited for bid on or after 7/1/08)

- Raises the threshold for public work projects subject to the Wicks Law requiring separate specifications and bidding for the plumbing, heating and electrical work. The total project's threshold would increase from \$50,000 to: \$3 million in Bronx, Kings, New York, Queens and Richmond counties; \$1.5 million in Nassau, Suffolk and Westchester counties; and \$500,000 in all other counties.
- For projects below the monetary threshold, bidders must submit a sealed list naming each subcontractor for the plumbing, HVAC and electrical work and the amount to be paid to each. The list may not be changed unless the public owner finds a legitimate construction need, including a change in specifications or costs or use of a Project Labor Agreement (PLA), and must be open to public inspection.
- Allows the state and local agencies and authorities to waive the Wicks Law and use a PLA if it will provide the best work at the lowest possible price. If a PLA is used, all contractors shall participate in apprentice training programs in the trades of work it employs that have been approved by the Department of Labor (DOL) for not less than three years. They shall also have at least one graduate in the last three years and use affirmative efforts to retain minority apprentices. PLA's would be exempt from Wicks, but deemed to be public work subject to prevailing wage enforcement.
- The Commissioner of Labor shall have the power to enforce separate specification requirements on projects, and may issue stop-bid orders against public owners for non-compliance.
- Other new monetary thresholds, and similar sealed bidding for non-Wicks projects, would apply to certain public authorities including municipal housing authorities, NYC Construction Fund, Yonkers Educational Construction Fund, NYC Municipal Water Finance Authority, Buffalo Municipal Water Finance Authority, Westchester County Health Care Association, Nassau County Health Care Corp., Clifton-Fine Health Care Corp., Erie County Medical Center Corp., NYC Solid Waste Management Facilities, and the Dormitory Authority.
- Reduces from 15 to 7 days the period in which contractors must pay subcontractors.

## **IMPORTANT INFORMATION**

**Regarding Use of Form PW30.1  
(Previously 30R)**

**“Employer Registration for Use of 4 Day / 10 Hour Work Schedule”**

### **To use the ‘4 Day / 10 Hour Work Schedule’:**

There **MUST** be a *Dispensation of Hours (PW30)* in place on the project

***AND***

You **MUST** register your intent to work 4 / 10 hour days, by completing the PW30.1 Form.

***REMEMBER...***

The ‘4 Day / 10 Hour Work Schedule’ applies **ONLY** to Job Classifications and Counties listed on the PW30.1 Form.

Do not write in any additional Classifications or Counties.

**(Please note :** For each Job Classification check the individual wage schedule for specific details regarding their 4/10 hour day posting.)



# Instructions for Completing Form PW30.1

(Previously 30R)

## “Employer Registration for Use of 4 Day / 10 Hour Work Schedule”

### ***Before completing Form PW30.1 check to be sure ...***

- There is a *Dispensation of Hours* in place on the project.
- The 4 Day / 10 Hour Work Schedule applies to the Job Classifications you will be using.
- The 4 Day / 10 Hour Work Schedule applies to the County / Counties where the work will take place.

### **Instructions (Type or Print legibly):**

#### Contractor Information:

- Enter the Legal Name of the business, FEIN, Street Address, City, State, Zip Code; the Company’s Phone and Fax numbers; and the Company’s email address (if applicable)
- Enter the Name of a Contact Person for the Company along with their Phone and Fax numbers, and the personal email address (if applicable)

#### Project Information:

- Enter the Prevailing Rate Case number (PRC#) assigned to this project
- Enter the Project Name / Type (i.e. Smithtown CSD – Replacement of HS Roof)
- Enter the Exact Location of Project (i.e. Smithtown HS, 143 County Route #2, Smithtown, NY; Bldgs. 1 & 2)
- If you are a Subcontractor, enter the name of the Prime Contractor for which you work
- On the Checklist of Job Classifications -
  - Go to pages 2 and 3 of the form
  - Place a checkmark in the box to the right of the Job Classification you are choosing
  - Mark all Job Classifications that apply

\*\*\*Do not write in any additional Classifications or Counties.\*\*\*

#### Requestor Information:

- Enter the name of the person submitting the registration, their title with the company , and the date the registration is filled out

#### Return Completed Form:

- **Mail** the completed PW30.1 form to: NYSDOL Bureau of Public Work, SOBC – Bldg.12 – Rm.130, Albany, NY 12240 **-OR-**
- **Fax** the completed PW30.1 form to: NYSDOL Bureau of Public Work at (518)485-1870



Bureau of Public Work Harriman
State Office Campus
Building 12, Room 130
Albany, New York 12240
Phone: (518) 457-5589 | Fax: (518) 485-1870
www.labor.ny.gov

Employer Registration for Use of 4 Day / 10 Hour Work Schedule

Before completing this form, make sure that:

- There is a Dispensation of Hours in place on the project.
The 4 Day / 10 Hour Work Schedule applies to the Job Classifications you will be using.
The 4 Day / 10 Hour Work Schedule applies to the County / Counties where the work will take place.

Please type or print the requested information and then mail or fax to the address above.

Contractor Information

Company Name: FEIN:
Address:
City: State: Zip Code:
Phone No: Fax No: Email:
Contact Person:
Phone No: Fax No: Email:

Project Information

Project PRC#: Project Name/Type:
Exact Location of Project: County:
(If you are Subcontractor)
Prime Contractor Name:

Job Classification(s) to Work 4/10 Schedule: (Choose all that apply on Job Classification Checklist - Pages 3-8)
\*\*\* Do not write in any additional Classifications or Counties\*\*\*

Requestor Information

Name:
Title: Date:

Please use the list below with the number assigned to each county as a reference to the corresponding numbers listed in the following pages under **Entire Counties & Partial Counties**.

- |     |                             |     |                                 |
|-----|-----------------------------|-----|---------------------------------|
| 1.  | Albany County               | 33. | Oneida County                   |
| 2.  | Allegany County             | 34. | Onondaga County                 |
| 3.  | Bronx County                | 35. | Ontario County                  |
| 4.  | Broome County               | 36. | Orange County                   |
| 5.  | Cattaraugus County          | 37. | Orleans County                  |
| 6.  | Cayuga County               | 38. | Oswego County                   |
| 7.  | Chautauqua County           | 39. | Otsego County                   |
| 8.  | Chemung County              | 40. | Putnam County                   |
| 9.  | Chenango County             | 41. | Queens County                   |
| 10. | Clinton County              | 42. | Rensselaer County               |
| 11. | Columbia County             | 43. | Richmond County (Staten Island) |
| 12. | Cortland County             | 44. | Rockland County                 |
| 13. | Delaware County             | 45. | Saint Lawrence County           |
| 14. | Dutchess County             | 46. | Saratoga County                 |
| 15. | Erie County                 | 47. | Schenectady County              |
| 16. | Essex County                | 48. | Schoharie County                |
| 17. | Franklin County             | 49. | Schuyler County                 |
| 18. | Fulton County               | 50. | Seneca County                   |
| 19. | Genesee County              | 51. | Steuben County                  |
| 20. | Greene County               | 52. | Suffolk County                  |
| 21. | Hamilton County             | 53. | Sullivan County                 |
| 22. | Herkimer County             | 54. | Tioga County                    |
| 23. | Jefferson County            | 55. | Tompkins County                 |
| 24. | Kings County (Brooklyn)     | 56. | Ulster County                   |
| 25. | Lewis County                | 57. | Warren County                   |
| 26. | Livingston County           | 58. | Washington County               |
| 27. | Madison County              | 59. | Wayne County                    |
| 28. | Monroe County               | 60. | Westchester County              |
| 29. | Montgomery County           | 61. | Wyoming County                  |
| 30. | Nassau County               | 62. | Yates County                    |
| 31. | New York County (Manhattan) |     |                                 |
| 32. | Niagara County              |     |                                 |

### Job Classification Checklist

(Place a checkmark by all classifications that will be using the 4/10 schedule)

\*\*\* Do not write in any additional Classifications or Counties\*\*\*

Job Classification	Tag #	Entire Counties	Partial Counties	Check Box
Carpenter – Building	276B-All	7	2 ,5	
Carpenter – Building	276B-Cat	15	5	
Carpenter – Building	276-B-LIV	26, 28, 35, 59	61	
Carpenter – Building	276B-Gen	19, 32, 37	61	
Carpenter – Heavy & Highway	276HH-All	2, 5, 7		
Carpenter – Heavy & Highway	276HH-Erie	15		
Carpenter – Heavy & Highway	276HH- Gen	19, 32, 37, 61		
Carpenter – Heavy & Highway	276HH-Liv	26, 28, 35, 59		
Carpenter – Residential	276R-All	7	2, 5	
Carpenter – Building	277B-Bro	4, 54		
Carpenter – Building	277B-CAY	6, 50, 62		
Carpenter – Building	277B-CS	8, 12, 49, 51, 55	2	
Carpenter – Building	277 JLS	23, 25, 45		
Carpenter – Building	277 omh	22, 27, 33		
Carpenter – Building	277 On	34		
Carpenter – Building	277 Os	38		
Carpenter – Building	277CDO Bldg	9, 13, 39		
Carpenter – Heavy & Highway	277CDO HH	9, 13, 39		
Carpenter – Heavy & Highway	277HH-BRO	4, 6, 8, 12, ,22, 23, 25, 27, 33, 34, 38, 45, 49, 50, 51, 54, 55, 62		
Carpenter – Building	291B-Alb	1, 18, 20, 29, 42, 47, 48		
Carpenter – Building	291B-Cli	10, 16, 17		
Carpenter – Building	291B-Ham	21, 57, 58		
Carpenter – Building	291B-Sar	46		
Carpenter – Heavy & Highway	291HH-Alb	1, 10, 16, 17,18, 20, 21, 29, 42, 46, 47, 48, 57, 58		
Electrician	25m	30, 52		
Electrician – Teledata Cable Splicer	43	12, 22, 27, 33, 38	6, 9, 34, 39, 55, 59	

### Job Classification Checklist

(Place a checkmark by all classifications that will be using the 4/10 schedule)

\*\*\* Do not write in any additional Classifications or Counties\*\*\*

Job Classification	Tag #	Entire Counties	Partial Counties	Check Box
Electrician	86	26, 28	19, 35, 37, 59, 61	
Electrician	840 Teledata and 840 Z1	62	6, 34, 35, 50, 59	
Electrician	910	10, 16, 17, 23, 25, 45		
Electrical Lineman	1049Line/Gas	30, 41, 52		
Electrical Lineman	1249a	1, 2, 4, 5, 6, 7, 8, 9, 10, 11, 12, 13, 14, 15, 16, 17, 18, 19, 20, 21, 22, 23, 25, 26, 27, 28, 29, 32, 33, 34, 35, 36, 37, 38, 39, 40, 42, 44, 46, 47, 48, 49, 50, 45, 51, 53, 54, 55, 56, 57, 58, 59, 61, 62		
Electrical Lineman	1249a West	60		
Electrical Lineman	1249a-LT	1, 2, 4, 5, 6, 7, 8, 9, 10, 12, 13, 15, 16, 17, 18, 19, 20, 21, 22, 23, 25, 26, 27, 28, 29, 32, 33, 34, 35, 37, 38, 39, 42, 46, 47, 48, 49, 50, 45, 51, 53, 54, 55, 57, 58, 59, 61, 62		
Electrical Lineman	1249aREG8LT	11, 14, 36, 40, 44, 56		
Electrical Lineman	1249aWestLT	60		
Elevator Constructor	138	11, 14, 20, 36, 40, 53, 56	13, 44, 60	
Elevator Constructor	14	2, 5, 7, 15, 19, 32, 37, 61		
Elevator Constructor	27	8, 26, 28, 35, 49, 50, 51, 59, 62		
Elevator Constructor	35	1, 10, 16, 18, 21, 22, 29, 39, 42, 46, 47, 48, 57, 58		
Elevator Constructor	62.1	4, 6, 9, 12, 23, 25, 27, 33, 34, 38, 45, 54, 55	13	
Glazier	201	1, 10, 11, 16, 17, 18, 20, 21, 29, 42, 46, 47, 48, 57, 58		
Glazier	660r	2, 5, 7, 15, 19, 32, 37, 61		
Glazier	660	2, 5, 7, 15, 19, 32, 37, 61		
Glazier	677.1	23, 25, 26, 28, 35, 45, 50, 59, 62		
Glazier	677Z-2	6, 12, 22, 27, 33, 34, 38		
Glazier	677z3	4, 8, 9, 13, 39, 49, 51, 54, 55		
Glazier	677r.2	6, 12, 22, 27, 33, 34, 38		
Insulator – Heat & Frost	30-Syracuse	4, 6, 8, 9, 12, 22, 23, 25, 27, 33, 34, 38, 39, 49, 50, 45, 54, 55		
Laborer – Building	621b	2, 7	5	
Laborer – Building	633 bON	34		

**Job Classification Checklist**

**(Place a checkmark by all classifications that will be using the 4/10 schedule)**

\*\*\* Do not write in any additional Classifications or Counties\*\*\*

<b>Job Classification</b>	<b>Tag #</b>	<b>Entire Counties</b>	<b>Partial Counties</b>	<b>Check Box</b>
Laborer – Building	633b Cay	6		
Laborer – Building	633bOS	38		
Laborer – Building	785(7)	4	9, 13, 54	
Laborer – Building	785B-CS	8, 51	49	
Laborer – Building	7-785b	12, 55	49, 54	
Laborers – Heavy & Highway	157h/h	47	18, 29, 46	
Laborers – Heavy & Highway	190 h/h	1, 42, 58	11, 20, 46	
Laborers – Heavy & Highway	35/2h	21, 22, 27, 33	18, 29	
Laborer – Residential	621r	2, 7	5	
Laborers – Tunnel	157	47	18, 29, 46	
Laborers – Tunnel	35T	21, 22, 27, 33	18, 29	
Laborers – Tunnel	190	1, 42, 58	11, 20, 46	
Mason – Building	2TS.1	1, 10,11, 16, 17, 18, 20, 21, 29, 42, 46, 47, 48, 57, 58		
Mason – Building	2TS.2	22, 23, 25, 33, 45	27	
Mason – Building	2TS.3	6, 34, 38	27	
Mason – Building	2b-on	34		
Mason – Building	2b.1	1, 11, 18, 20, 21, 29, 42, 46, 47, 48, 58	57	
Mason – Building	2b.2	22, 33	25	
Mason – Building	2b.3	6, 34	27	
Mason – Building	2b.4	38		
Mason – Building	2b.5	23	25	
Mason – Building	2b.6	45		
Mason – Building	2b.8	10, 16, 17	57	
Mason – Building	3b-Co-Z2	8, 49, 51	2	
Mason – Building	3B-Z1	19, 26, 28, 35, 50, 59, 61, 62		
Mason – Building – Residential	3B-Z1R	19, 26, 28, 35, 50, 59, 61, 62		
Mason – Building	3B-Bing-Z2	4, 9, 13, 39, 54		
Mason – Building	3B-lth-Z2	12, 55		

### Job Classification Checklist

(Place a checkmark by all classifications that will be using the 4/10 schedule)

\*\*\* Do not write in any additional Classifications or Counties\*\*\*

Job Classification	Tag #	Entire Counties	Partial Counties	Check Box
Mason – Building	3B-Jam-Z2	7	2, 5	
Mason – Building – Residential	3B-Jam-Z2R	2, 4, 8, 7, 9, 12, 39, 13, 49, 51, 54, 55	5	
Mason – Building	3B-Z3	15, 32	5	
Mason – Building	3B-Z3.Orleans	37		
Mason – Residential	3B-Z3R	15, 32	5	
Mason – Residential	3B-z3R.Orleans	37		
Mason - Heavy & Highway	3h	2, 4, 8, 7, 9, 12, 13, 19, 26, 28, 35, 37, 39, 49, 50, 51, 54, 55, 59, 61, 62	5, 15, 32	
Mason – Tile Finisher	3TF-Z1	19, 26, 28, 35, 50, 59, 61, 62		
Mason – Tile Finisher	3TF-Z2	2, 4, 8, 7, 9, 12, 13, 39, 49, 51, 54, 55	5	
Mason – Tile Finisher	3TF-Z3	15, 32, 37	5	
Mason – Tile Finisher	3TF-Z1R	19, 26, 28, 35, 50, 59, 61, 62		
Mason – Tile Finisher	3TF-Z2R	2, 4, 7, 9, 12, 13, 39, 49, 51, 54, 55	5	
Mason – Tile Finisher	3TF-Z3R	15, 32, 37	5	
Mason – Tile Setter	3TS-Z1	19, 26, 28, 35, 50, 59, 61, 62		
Mason – Tile Setter Residential	3TS-Z1R	19, 26, 28, 35, 50, 59, 61, 62		
Mason – Tile Setter	3TS-Z2	2, 4, 7, 8, 9, 12, 13, 39, 49, 51, 54, 55	5	
Mason – Tile Setter Residential	3TS-Z2R	2, 4, 7, 8, 9, 12, 13, 39, 49, 51, 54, 55	5	
Mason – Tile Setter	3TS-Z3	15, 32, 37	5	
Mason – Tile Setter Residential	3TS-Z3R	15, 32, 37	5	
Mason – Building/Heavy & Highway	780	3, 24, 30, 31, 41, 43, 52		
Operating Engineer - Heavy & Highway	137H/H	40, 60	14	
Operating Engineer – Heavy & Highway	158-832H	2, 8, 26, 28, 35, 49, 51, 59, 62	19	
Operating Engineer – Heavy & Highway	158-H/H	1, 4, 9, 10, 11, 14, 16, 17, 18, 20, 21, 22, 29, 39, 42, 46, 47, 48, 54, 57, 58		
Operating Engineer – Heavy & Highway	158-545h	6, 12, 23, 25, 27, 33, 38, 45, 50, 55		
Painter	1456-LS	1, 3, 10, 11, 14, 16, 17, 18, 20, 21, 24, 29, 30, 31, 36, 40, 41, 42, 43, 44, 46, 47, 48, 52, 53, 56, 57, 58, 60		
Painter	150	28, 59, 62	26, 35	

### Job Classification Checklist

(Place a checkmark by all classifications that will be using the 4/10 schedule)

\*\*\* Do not write in any additional Classifications or Counties\*\*\*

Job Classification	Tag #	Entire Counties	Partial Counties	Check Box
Painter	178 B	4, 9, 54		
Painter	178 E	8, 49	51	
Painter	178 I	12, 55		
Painter	178 O	13, 39		
Painter	31	6, 22, 27, 33, 34, 50	25, 35, 38	
Painter	38.O		38	
Painter	38.W	23, 45	25	
Painter	4- Buf,Nia,Olean	2, 15, 19, 32, 37, 61	5, 7, 26, 51	
Painter	4-Jamestown		5, 7	
Sheetmetal Worker	46	26, 28, 35, 50, 59, 62		
Sheetmetal Worker	46r	26, 28, 35, 50, 59, 62		
Teamsters – Heavy & Highway	294h/h	1, 11, 18, 20, 29, 42, 46, 47, 48, 58	57	
Teamsters – Heavy & Highway	317bhh	6, 12, 50, 51, 55, 62	2	
Teamsters - Building/Heavy & Highway	456	40, 60		



## Introduction to the Prevailing Rate Schedule

### Information About Prevailing Rate Schedule

This information is provided to assist you in the interpretation of particular requirements for each classification of worker contained in the attached Schedule of Prevailing Rates.

#### Classification

It is the duty of the Commissioner of Labor to make the proper classification of workers taking into account whether the work is heavy and highway, building, sewer and water, tunnel work, or residential, and to make a determination of wages and supplements to be paid or provided. It is the responsibility of the public work contractor to use the proper rate. If there is a question on the proper classification to be used, please call the district office located nearest the project. District office locations and phone numbers are listed below.

Prevailing Wage Schedules are issued separately for "General Construction Projects" and "Residential Construction Projects" on a county-by-county basis.

General Construction Rates apply to projects such as: Buildings, Heavy & Highway, and Tunnel and Water & Sewer rates.

Residential Construction Rates generally apply to construction, reconstruction, repair, alteration, or demolition of one family, two family, row housing, or rental type units intended for residential use.

Some rates listed in the Residential Construction Rate Schedule have a very limited applicability listed along with the rate. Rates for occupations or locations not shown on the residential schedule must be obtained from the General Construction Rate Schedule. Please contact the local Bureau of Public Work office before using Residential Rate Schedules, to ensure that the project meets the required criteria.

#### Payrolls and Payroll Records

Contractors and subcontractors are required to establish, maintain, and preserve for not less than six (6) years, contemporaneous, true, and accurate payroll records.

Every contractor and subcontractor shall submit to the Department of Jurisdiction (Contracting Agency), within thirty (30) days after issuance of its first payroll and every thirty (30) days thereafter, a transcript of the original payrolls, subscribed and affirmed as true under penalty of perjury.

#### Paid Holidays

Paid Holidays are days for which an eligible employee receives a regular day's pay, but is not required to perform work. If an employee works on a day listed as a paid holiday, this remuneration is in addition to payment of the required prevailing rate for the work actually performed.

#### Overtime

At a minimum, all work performed on a public work project in excess of eight hours in any one day or more than five days in any workweek is overtime. However, the specific overtime requirements for each trade or occupation on a public work project may differ. Specific overtime requirements for each trade or occupation are contained in the prevailing rate schedules.

Overtime holiday pay is the premium pay that is required for work performed on specified holidays. It is only required where the employee actually performs work on such holidays.

The applicable holidays are listed under HOLIDAYS: OVERTIME. The required rate of pay for these covered holidays can be found in the OVERTIME PAY section listings for each classification.

#### Supplemental Benefits

Particular attention should be given to the supplemental benefit requirements. Although in most cases the payment or provision of supplements is straight time for all hours worked, some classifications require the payment or provision of supplements, or a portion of the supplements, to be paid or provided at a premium rate for premium hours worked. Supplements may also be required to be paid or provided on paid holidays, regardless of whether the day is worked. The Overtime Codes and Notes listed on the particular wage classification will indicate these conditions as required.

#### Effective Dates

When you review the schedule for a particular occupation, your attention should be directed to the dates above the column of rates. These are the dates for which a given set of rates is effective. The rate listed is valid until the next effective rate change or until the new annual determination which takes effect on July 1 of each year. All contractors and subcontractors are required to pay the current prevailing rates of wages and supplements. If you have any questions please contact the Bureau of Public Work or visit the New York State Department of Labor website ([www.labor.ny.gov](http://www.labor.ny.gov)) for current wage rate information.

#### Apprentice Training Ratios

The following are the allowable ratios of registered Apprentices to Journey-workers.

For example, the ratio 1:1,1:3 indicates the allowable initial ratio is one Apprentice to one Journeyworker. The Journeyworker must be in place on the project before an Apprentice is allowed. Then three additional Journeyworkers are needed before a second Apprentice is allowed. The last ratio repeats indefinitely. Therefore, three more Journeyworkers must be present before a third Apprentice can be hired, and so on.

Please call Apprentice Training Central Office at (518) 457-6820 if you have any questions.

Title (Trade)	Ratio
Boilermaker (Construction)	1:1,1:4
Boilermaker (Shop)	1:1,1:3
Carpenter (Bldg.,H&H, Pile Driver/Dockbuilder)	1:1,1:4
Carpenter (Residential)	1:1,1:3
Electrical (Outside) Lineman	1:1,1:2
Electrician (Inside)	1:1,1:3
Elevator/Escalator Construction & Modernizer	1:1,1:2
Glazier	1:1,1:3
Insulation & Asbestos Worker	1:1,1:3
Iron Worker	1:1,1:4
Laborer	1:1,1:3
Mason	1:1,1:4
Millwright	1:1,1:4
Op Engineer	1:1,1:5
Painter	1:1,1:3
Plumber & Steamfitter	1:1,1:3
Roofer	1:1,1:2
Sheet Metal Worker	1:1,1:3
Sprinkler Fitter	1:1,1:2

If you have any questions concerning the attached schedule or would like additional information, please contact the nearest BUREAU of PUBLIC WORK District Office or write to:

New York State Department of Labor  
 Bureau of Public Work  
 State Office Campus, Bldg. 12  
 Albany, NY 12240

District Office Locations:	Telephone #	FAX #
Bureau of Public Work - Albany	518-457-2744	518-485-0240
Bureau of Public Work - Binghamton	607-721-8005	607-721-8004
Bureau of Public Work - Buffalo	716-847-7159	716-847-7650
Bureau of Public Work - Garden City	516-228-3915	516-794-3518
Bureau of Public Work - Newburgh	845-568-5287	845-568-5332
Bureau of Public Work - New York City	212-932-2419	212-775-3579
Bureau of Public Work - Patchogue	631-687-4882	631-687-4902
Bureau of Public Work - Rochester	585-258-4505	585-258-4708
Bureau of Public Work - Syracuse	315-428-4056	315-428-4671
Bureau of Public Work - Utica	315-793-2314	315-793-2514
Bureau of Public Work - White Plains	914-997-9507	914-997-9523
Bureau of Public Work - Central Office	518-457-5589	518-485-1870

**Cattaraugus County General Construction**

**Boilermaker** **08/01/2019**

**JOB DESCRIPTION** Boilermaker **DISTRICT 12**

**ENTIRE COUNTIES**

Allegany, Cattaraugus, Chautauqua, Chemung, Erie, Genesee, Livingston, Monroe, Niagara, Ontario, Orleans, Schuyler, Steuben, Wayne, Wyoming, Yates

**WAGES**

Per hours:	07/01/2019	01/01/2020
		Additional
Boilermaker	\$ 34.10	\$ 1.25

The wage rate will be 90% of the above for Maintenance work on boilers less than 100,000 pph.

Four (4), ten (10) hour days may be worked at straight time during a week, Monday thru Thursday. Friday may be used as a make-up day.

NOTE - In order to use the '4 Day/10 Hour Work schedule', as your normal schedule, you must submit an 'Employer Registration for Use of 4 Day/10 Hour Work Schedule,' form PW30.1; and there must be a dispensation of hours in place on the project. If the PW30.1 is not submitted you may be liable for overtime payments for work over 8 hours per day.

**SUPPLEMENTAL BENEFITS**

Per hour: \$ 30.15\*

\*NOTE: \$28.91 of this amount is for every Hour "Paid"

**OVERTIME PAY**

See (B, E, Q) on OVERTIME PAGE

**HOLIDAY**

Paid: See (1) on HOLIDAY PAGE  
 Overtime: See (5, 6) on HOLIDAY PAGE

**REGISTERED APPRENTICES**

1st Term at 12 Months  
 Terms 3-8 at 6 Months

Per Hour:

1st 65%					
3rd 70%	4th 75%	5th 80%	6th 85%	7th 90%	8th 95%

Supplemental Benefits per hour:

1st to 6th	\$ 29.15**
7th to 8th	\$30.15***

\*\*NOTE: \$27.91 of this amount is for every Hour "Paid"

\*\*\*NOTE: \$28.91 of this amount is for every Hour "Paid"

12-7

**Carpenter - Building** **08/01/2019**

**JOB DESCRIPTION** Carpenter - Building **DISTRICT 12**

**ENTIRE COUNTIES**

Chautauqua

**PARTIAL COUNTIES**

Allegany: Entire county except the Township of Alfred.  
 Cattaraugus: Entire county except the Township of Perrysburg and the Village of Gowanda.

**WAGES**

Per hour:	07/01/2019
Carpenter	\$ 27.10
Floorlayer	27.10
Certified Welder	28.10
Hazardous Waste Worker	28.60
Diver-Dry Day	28.10
Dive Tender	28.10
Diver-Wet Day**	61.25

Hazardous Waste Worker: Hazardous sites requiring personal protective equipment.

\*\* Diver rate applies to all hours worked on the day of dive.

Depth pay for divers:	0' to 80'	no additional fee
	81' to 100'	additional \$0.50 per foot
	101' to 150'	additional \$0.75 per foot
	151' and deeper	additional \$1.25 per foot
Penetration pay:	0' to 50'	no additional fee
	51' to 100'	additional \$0.75 per foot
	101' and deeper	additional \$1.00 per foot

Four (4), ten (10) hour days may be worked at straight time during a week, Monday thru Thursday. Friday may be used as a make-up day.

NOTE - In order to use the '4 Day/10 Hour Work Schedule,' as your normal schedule, you must submit an 'Employer Registration for Use of 4 Day/10 Hour Work Schedule,' form PW30.1; and there must be a dispensation of hours in place on the project. If the PW30.1 is not submitted you may be liable for overtime payments for work over 8 hours per day.

**SUPPLEMENTAL BENEFITS**

Per hour worked:

Carpenter(s)	\$ 19.45
Diver Wet	19.45
Diver Dry & Tender	19.45

**OVERTIME PAY**

See (B, E, E2, Q) on OVERTIME PAGE

**HOLIDAY**

Paid: See (1) on HOLIDAY PAGE  
 Overtime: See (5, 6) on HOLIDAY PAGE

**REGISTERED APPRENTICES**

Wages per hour:

One year terms at the following percentage of Journeyman's base wage:

Indentured Prior to 1/1/2016

1st	2nd	3rd	4th
50%	60%	70%	80%

Indentured After 01/01/2016

1st	2nd	3rd	4th	5th
50%	60%	65%	70%	80%

Supplemental benefits per hour worked:

1st	2nd	3rd	4th	5th
\$11.69	\$11.69	\$14.29	\$14.29	\$14.29

12-276B-All

**Carpenter - Building**

**08/01/2019**

**JOB DESCRIPTION** Carpenter - Building

**DISTRICT** 12

**ENTIRE COUNTIES**

Erie

**PARTIAL COUNTIES**

Cattaraugus: Townships of Persia and Perrysburg

**WAGES**

Per hour: 07/01/2019

Building:

Carpenter	\$ 32.40
FloorLayer	32.40
Certified Welder	33.40
Hazardous Waste Worker	33.90
Diver-Dry Day	33.40
Diver Tender	33.40
Diver-Wet Day***	61.25

Hazardous Waste Worker: Hazardous sites requiring personal protective equipment.

\*\*\* Diver rate applies to all hours worked on the day of dive.

Depth pay for divers:	0' to 80'	no additional fee
	81' to 100'	additional \$0.50 per foot
	101' to 150'	additional \$0.75 per foot
	151' and deeper	additional \$1.25 per foot
Penetration pay:	0' to 50'	no additional fee
	51' to 100'	additional \$0.75 per foot
	101' and deeper	additional \$1.00 per foot

Four (4), ten (10) hour days may be worked at straight time during a week, Monday thru Thursday. Friday may be used as a make-up day.

NOTE - In order to use the '4 Day/10 Hour Work schedule' as your normal schedule, you must submit an 'Employer Registration for Use of 4 Day/10 Hour Work Schedule,' form PW30.1; and there must be a dispensation of hours in place on the project. If the PW30.1 is not submitted you may be liable for overtime payments for work over 8 hours per day.

**SUPPLEMENTAL BENEFITS**

Per hour worked:

Carpenter(s)	\$ 28.18
Diver(s)	28.18

**OVERTIME PAY**

See (B, E, E2, Q) on OVERTIME PAGE

**HOLIDAY**

Paid: See (1) on HOLIDAY PAGE  
 Overtime: See (5, 6) on HOLIDAY PAGE

**REGISTERED APPRENTICES**

Wages per hour:

One year terms at the following percentage of Journeyman's base wage:

Indentured Prior to 01/01/2016

1st	2nd	3rd	4th
50%	60%	70%	80%

Indentured After 01/01/2016

1st	2nd	3rd	4th	5th
50%	60%	65%	70%	80%

Supplemental Benefits per hour worked:

1st	2nd	3rd	4th	5th
\$11.75	\$11.75	\$14.35	\$14.35	\$14.35

12-276B-Cat

**Carpenter - Building / Heavy&Highway**

**08/01/2019**

**JOB DESCRIPTION** Carpenter - Building / Heavy&Highway

**DISTRICT 2**

**ENTIRE COUNTIES**

Albany, Allegany, Broome, Cattaraugus, Cayuga, Chautauqua, Chemung, Chenango, Clinton, Columbia, Cortland, Delaware, Erie, Essex, Franklin, Fulton, Genesee, Greene, Hamilton, Herkimer, Jefferson, Lewis, Livingston, Madison, Monroe, Montgomery, Niagara, Oneida, Onondaga, Ontario, Orleans, Oswego, Otsego, Rensselaer, Saratoga, Schenectady, Schoharie, Schuyler, Seneca, St. Lawrence, Steuben, Sullivan, Tioga, Tompkins, Ulster, Warren, Washington, Wayne, Wyoming, Yates

**PARTIAL COUNTIES**

Orange: The area lying on Northern side of Orange County demarcated by a line drawn from the Bear Mountain Bridge continuing east to the Bear Mountain Circle, continue North on 9W to the town of Cornwall where County Road 107 (also known as Quaker Rd) crosses under 9W, then east on County Road 107 to Route 32, then north on Route 32 to Orrs Mills Rd, then west on Orrs Mills Rd to Route 94, continue west and south on Route 94 to the Town of Chester, to the intersection of Kings Highway, continue south on Kings Highway to Bellvale Rd, west on Bellvale Rd to Bellvale Lakes Rd, then south on Bellvale Lakes Rd to Kain Rd, southeast on Kain Rd to Route 17A, then north and southeast along Route 17A to Route 210, then follow Route 210 to NJ Border.

**WAGES**

Wages per hour:	07/01/2019	07/01/2020	07/01/2021
		Additional	Additional

Carpenter - ONLY for  
 Artificial Turf/Synthetic

Sport Surface \$ 30.88 \$ 1.15 \$ 1.15

Note - Does not include the operation of equipment. Please see Operating Engineers rates.

**SUPPLEMENTAL BENEFITS**

Per hour:

Journeyman \$ 23.10

**OVERTIME PAY**

See (B, E, Q, X) on OVERTIME PAGE

**HOLIDAY**

Paid: See (5) on HOLIDAY PAGE

Overtime: See (5, 6, 16) on HOLIDAY PAGE

Notes:

When a holiday falls upon a Saturday, it shall be observed on the preceding Friday. When a holiday falls upon a Sunday, it shall be observed on the following Monday.

An employee taking an unexcused day off the regularly scheduled day before or after a paid Holiday shall not receive Holiday pay.

**REGISTERED APPRENTICES**

Wages per hour:

One year terms at the following percentage of Journeyman's wage:

1st	2nd	3rd	4th
55%	60%	70%	80%

Supplemental Benefits per hour:

1st year term	\$ 11.55
2nd year term	11.55
3rd year term	14.15
4th year term	14.15

2-42AtSS

**Carpenter - Heavy&Highway**

**08/01/2019**

**JOB DESCRIPTION** Carpenter - Heavy&Highway

**DISTRICT** 12

**ENTIRE COUNTIES**

Allegany, Cattaraugus, Chautauqua

**WAGES**

Per hour: 07/01/2019

Carpenter	\$ 31.23
Certified Welder	32.73
Diver-Dry Day	32.23
Diver-Wet Day**	56.23
Dive Tender	32.23
Hazardous Waste Worker	33.23
Pile Driver	35.11
Millwright	33.38
Effluent & Slurry Diver-Dry Day	48.35
Effluent & Slurry Diver-Wet Day	84.35

Hazardous Waste Worker: Hazardous sites requiring personal protective equipment.

\*\* Diver rate applies to all hours worked on the day of the dive.

Depth pay for divers:	0' to 50'	no additional fee
	51' to 100'	additional \$0.50 per foot
	101' to 150'	additional \$0.75 per foot
	151' to 200'	additional \$1.25 per foot
Penetration pay:	0' to 50'	no additional fee
	51' to 100'	additional \$0.75 per foot
	101' to deeper	additional \$1.00 per foot

Four (4), ten (10) hour days may be worked at straight time during a week, Monday thru Thursday. Friday may be used as a make-up day.

NOTE - In order to use the '4 Day/10 Hour Work schedule', as your normal schedule, you must submit an 'Employer Registration for Use of 4 Day/10 Hour Work Schedule,' form PW30.1; and there must be a dispensation of hours in place on the project. If the PW30.1 is not submitted you may be liable for overtime payments for work over 8 hours per day.

**SUPPLEMENTAL BENEFITS**

Per hour worked:

Carpenter(s)	\$ 23.10
Diver Wet	24.44
Diver Dry & Tender	24.44
Pile Driver	25.05

**OVERTIME PAY**

See (B, E, Q) on OVERTIME PAGE

**HOLIDAY**

Paid: See (2, 17) on HOLIDAY PAGE  
 Overtime: See (5, 6) on HOLIDAY PAGE

**REGISTERED APPRENTICES**

Wages per hour:

One year terms at the following percentage of Journeyman's wage:

Indentured Prior to 01/01/2016

1st	2nd	3rd	4th
55%	60%	70%	80%

Indentured After 01/01/2016

1st	2nd	3rd	4th	5th
55%	60%	65%	70%	80%

Supplemental benefits per hour worked:

1st	2nd	3rd	4th	5th
\$11.55	\$11.55	\$14.15	\$14.15	\$14.15

12-276HH-All

**Electrician**

**08/01/2019**

**JOB DESCRIPTION** Electrician

**DISTRICT 3**

**ENTIRE COUNTIES**

Erie

**PARTIAL COUNTIES**

Cattaraugus: Only the Townships of Ashford, East Otto, Ellicottville, Farmersville, Freedom, Franklinville, Lyndon, Machias, Mansfield, New Albion, Otto, Perrysburg, Persia and Yorkshire.

Genesee: Only the Townships of Alabama, Alexander, Darien, Oakfield, Pembroke and that portion of the Towns of Batavia and Elba that are west of Little Tonawanda Creek; Tonawanda Creek; the City limits of Batavia (in effect prior to Feb. 1, 1970) and State Highway 98 north of the City of Batavia, then north on Highway 98 to the Orleans County line.

Wyoming: Only the Townships of Arcade, Attica, Bennington, Eagle, Java, Orangeville, Sheldon and Wethersfield.

**WAGES**

Per hour:	07/01/2019	06/01/2020
		Additional
Electrician*	\$ 35.64	\$1.80

\* Includes teledata work

When shift work is mandated either in the job specification or by the contracting agency the following premiums apply:

17.3% for work from 4:30PM - 1:00AM

31.4% for work from 12:30AM - 9:00AM

Additional \$0.50/hr in shafts over 25 ft. deep and in underground tunnels over 75 ft. long.

Additional \$0.75/hr for work on toothpicks, structural steel, temporary platforms, swinging scaffolds, boatswain chairs, smoke stacks or water towers 30 ft above the floor or for work on rolling scaffolds and ladders over 50 ft.

Additional \$1.50/hr for Cable Splicers on such work as lead, and shielded cable and splices or terminations on cable 5KV and above.

Additional \$1.00/hr for Hot work (Atomic plants).

Additional \$2.00/hr for work on radio, TV, light towers and floating platforms or climbing ladders in excess of 100 ft. high.

**SUPPLEMENTAL BENEFITS**

Per hour:

\$ 28.10\*

\* NOTE - add 3% of the posted straight time or applicable premium wage rate.

**OVERTIME PAY**

See (B, E, Q) on OVERTIME PAGE

**HOLIDAY**

Paid: See (1) on HOLIDAY PAGE  
 Overtime: See (5, 6) on HOLIDAY PAGE

**REGISTERED APPRENTICES**

Wages per hour:

Hour terms at the following wages:

0 to 1000 to 2000 to 3500 to 5000 to 6500 to 8000  
 \$ 13.20 \$ 14.25 \$ 16.05 \$ 19.60 \$ 24.95 \$ 28.50

Supplemental benefits per hour:

0 to 1000 to 5000 to 8000  
 \$ 12.51\* \$ 22.75\* \$ 28.10\*

\* NOTE - add 3% of the posted straight time or applicable premium wage rate.

3-41

**Electrician**

**08/01/2019**

**JOB DESCRIPTION** Electrician

**DISTRICT 3**

**ENTIRE COUNTIES**

Chautauqua

**PARTIAL COUNTIES**

Allegany: Only the Townships of Alma, Bolivar, Centerville, Clarksville, Cuba, Friendship, Genesee, New Hudson, Rushford, Wirt and that portion of the Townships of Amity, Angelica, Belfast, Caneadea and Scio that are west of the Genesee River.  
 Cattaraugus: Only the Townships of Allegany, Carrollton, Cold Spring, Conewango, Dayton, Great Valley, Hinsdale, Humphrey, Ischua, Leon, Little Valley, Napoli, Olean, Portville, Red House, Randolph, Salamanca and South Valley.

**WAGES**

Per hour:	07/01/2019	01/01/2020 Additional	01/01/2021 Additional
Electrician*	\$ 36.51	\$ 1.70	\$ 1.90

\* Includes teledata work.

When shift work is mandated either in the job specification or by the contracting agency the following premiums apply:

17.3% for work from 4:30PM - 1:00AM

31.4% for work from 12:30AM - 9:00AM

Additional 15% above wage for work 40' above floor, or in underground mines or tunnels or from suspension-type personnel lift equipment.

**SUPPLEMENTAL BENEFITS**

Per hour:

\$ 22.41\*

NOTE - add 3% of the posted straight time or applicable premium wage rate.

\* NOTE - \$10.72 of this amount is paid at straight time, the remaining balance of \$11.69 is paid at the same premium as the wages.

**OVERTIME PAY**

See (B, \*E, Q) on OVERTIME PAGE

\* Double-time for all work on Saturday in excess of 10 hours.

**HOLIDAY**

Paid: See (1) on HOLIDAY PAGE

Overtime: See (5, 6) on HOLIDAY PAGE

**REGISTERED APPRENTICES**

Wages per hour:

Hour terms at the following percentage of Journeyman's wage:

0 to	1001 to	2001 to	2751 to	3501 to	4251 to	5001 to	5751 to	6601 to	7351 to
1000	2000	2750	3500	4250	5000	5750	6600	7350	8200
40%	45%	55%	60%	65%	70%	75%	80%	85%	90%

Supplemental benefits per hour:

07/01/2018

\$ 8.27 \$ 8.27 \$ 14.89\* \$ 15.27\* \$ 18.32\* \$ 18.90\* \$ 19.49\* \$ 20.07\* \$ 20.66\* \$ 21.24\*

NOTE - add 3% of the posted straight time or applicable premium wage rate to all terms.

\* Note - \$10.72 of this amount is paid at straight time, the remaining balance is paid at the same premium as the wages.

3-106

**Elevator Constructor**

**08/01/2019**



**JOB DESCRIPTION** Elevator Constructor

**DISTRICT 3**

**ENTIRE COUNTIES**

Allegany, Cattaraugus, Chautauqua, Erie, Genesee, Niagara, Orleans, Wyoming

**WAGES**

Per hour:	07/01/2019
Elevator Constructor	\$ 49.81
Helper	34.87

**\*\* IMPORTANT NOTICE - EFFECTIVE 04/01/2009 \*\***

Four (4), ten (10) hour days may be worked at straight time during a week, Monday thru Thursday or Tuesday thru Friday.

NOTE - In order to use the '4 Day/10 Hour Work schedule', as your normal schedule, you must submit an 'Employer Registration for Use of 4 Day/10 Hour Work Schedule,' form PW30.1; and there must be a dispensation of hours in place on the project. If the PW30.1 is not submitted you may be liable for overtime payments for work over 8 hours per day.

**SUPPLEMENTAL BENEFITS**

Per hour:	\$ 33.71
-----------	----------

Note - add 6% of regular hourly rate for all hours worked.

**OVERTIME PAY**

See (D, O) on OVERTIME PAGE

**HOLIDAY**

Paid:	See (5, 6, 15, 16) on HOLIDAY PAGE
Overtime:	See (5, 6, 15, 16) on HOLIDAY PAGE

**REGISTERED APPRENTICES**

Wages per hour:

One year (1,700 hour each) terms at the following percentage of Journeyman's wage:

1st*	2nd	3rd	4th
55%	65%	70%	80%

Supplemental benefits per hour:

\$ 33.71

\* Note - 0-6 months of the 1st year term is paid at 50% of Journeyman's wage with no Supplemental benefits.

Note - add 6% of regular hourly rate for all hours worked.

3-14

**Glazier**

**08/01/2019**

**JOB DESCRIPTION** Glazier

**DISTRICT 3**

**ENTIRE COUNTIES**

Allegany, Cattaraugus, Chautauqua, Erie, Genesee, Niagara, Orleans, Wyoming

**WAGES**

Per hour:	07/01/2019	05/01/2020	05/01/2021
		Additional	Additional
Glazier	\$ 27.12	\$ 1.20	\$ 1.20
Working off Suspended			
Scaffold (Swing Stage)	28.12	1.20	1.20
Maintenance	16.94*	0.85	0.90

\* Note - This rate to be used only for all repair and replacement work such as glass breakage, glass replacement, door repair and board ups.

**\*\* IMPORTANT NOTICE \*\***

Four (4), ten (10) hour days may be worked at straight time during a week, Monday thru Thursday. Friday may be used as a make-up day.

NOTE - In order to use the '4 Day/10 Hour Work schedule', as your normal schedule, you must submit an 'Employer Registration for Use of 4 Day/10 Hour Work Schedule,' form PW30.1; and there must be a dispensation of hours in place on the project. If the PW30.1 is not submitted you may be liable for overtime payments for work over 8 hours per day.

**SUPPLEMENTAL BENEFITS**

Per hour:	
Journeymen Glazier	\$ 22.50
Maintenance	14.20

**OVERTIME PAY**

See (B, E2, F, R) on OVERTIME PAGE

**HOLIDAY**

Paid: See (1) on HOLIDAY PAGE for Glazier and Glazier Apprentices.  
 Paid: See (5, 6) on HOLIDAY PAGE for Maintenance  
 Overtime: See (5, 6) on HOLIDAY PAGE.

**REGISTERED APPRENTICES**

Wages per hour:

Glazier: 1000 hour terms at the following percentage of Journeyman's wage:

1st	2nd	3rd	4th	5th	6th	7th	8th
50%	55%	60%	65%	70%	75%	80%	90%

Supplemental benefits per hour:

1st & 2nd terms	\$ 7.95
3rd & 4th terms	8.80
All other terms	10.20

3-660

**Insulator - Heat & Frost**

**08/01/2019**

**JOB DESCRIPTION** Insulator - Heat & Frost

**DISTRICT 3**

**ENTIRE COUNTIES**

Allegany, Cattaraugus, Chautauqua, Erie, Niagara, Wyoming

**PARTIAL COUNTIES**

Genesee: Only the Townships of Alabama, Alexander, Darien, Oakfield and Pembroke.

**WAGES**

Per Hour: 07/01/2019  
 Heat & Frost Insulator \$ 33.70

**SUPPLEMENTAL BENEFITS**

Per hour: \$ 23.89

**OVERTIME PAY**

See (B, \*E, \*\*Q) on OVERTIME PAGE  
 \* Note - Double time after 10 hours on Saturday.  
 \*\* Note - Triple time on Labor Day if WORKED.

**HOLIDAY**

Paid: See (1) on HOLIDAY PAGE  
 Overtime: See (5, 6) on HOLIDAY PAGE

**REGISTERED APPRENTICES**

Wages per hour:

One year terms at the following percentage of Journeyman's wage:

1st	2nd	3rd	4th
50%	60%	70%	80%

Supplemental Benefits per hour:

1st and 2nd	\$ 18.99
All other terms	\$ 23.89

3-4

**Ironworker**

**08/01/2019**

**JOB DESCRIPTION** Ironworker

**DISTRICT 3**

**ENTIRE COUNTIES**

Cattaraugus, Chautauqua

**PARTIAL COUNTIES**

Allegany: Entire county except the Towns of Birdsall, Burns and Grove.  
 Erie: All except the Town of Grand Island north of Whitehaven Road.  
 Genesee: Only the Townships of Alabama, Alexander, Darien and Pembroke  
 Steuben: Only the Townships of Canisteo, Freemont, Greenwood, Hartsville, Hornell, Hornellsville, Howard, Jasper, Troupsburg and West Union  
 Wyoming: Only the Townships of Arcade, Attica, Bennington, Eagle, Gainsville, Java, Orangeville, Pike, Sheldon, Warsaw and Wethersfield.

**WAGES**

Per hour:	07/01/2019	07/01/2020 Additional	07/01/2021 Additional
Structural	\$ 31.10	\$ 1.25	\$ 1.25
Ornamental	31.10	1.25	1.25
Layout	31.10	1.25	1.25
Rodmen	31.10	1.25	1.25
Reinforcing	31.10	1.25	1.25
Welders	31.10	1.25	1.25
Riggers & Mach. Movers	31.10	1.25	1.25
Curtain Wall Erector	31.10	1.25	1.25
Window Erector	28.75	1.25	1.25
Fence Erector	29.67	1.25	1.25

**SUPPLEMENTAL BENEFITS**

Per hour:

Fence erectors	\$ 27.15
All others	28.65

**OVERTIME PAY**

See (B, E, Q) on OVERTIME PAGE

**HOLIDAY**

Paid: See (1) on HOLIDAY PAGE  
 Overtime: See (5, 6) on HOLIDAY PAGE

**REGISTERED APPRENTICES**

Wages per hour:

One year terms at the following wage:

1st	2nd	3rd	4th
\$ 16.50	\$ 18.50	\$ 20.50	\$ 22.50

Supplemental benefits per hour:

1st	2nd	3rd	4th
\$ 12.08	\$ 21.66	\$ 23.02	\$ 24.39

3-6

**Laborer - Building**

**08/01/2019**

**JOB DESCRIPTION** Laborer - Building

**DISTRICT 3**

**ENTIRE COUNTIES**

Allegany, Chautauqua

**PARTIAL COUNTIES**

Cattaraugus: Entire county except the Town of Perrysburg and the Village of Gowanda.

**WAGES**

Per hour:	07/01/2019	07/01/2020 Additional	07/01/2021 Additional
Basic and Flagman	\$ 24.27	\$ 1.00	\$ 1.10
Blaster, Nozzelman, Curb	25.27	1.00	1.10
and Flatwork Formsetter not	25.27	1.00	1.10
on structures, Pipelayer	25.27	1.00	1.10
Work 40 ft. and up	24.42	1.00	1.10
Hazardous Waste	25.77	1.00	1.10
Deleader & Asbestos Removal	26.27	1.00	1.10
OSHA Level C or	26.27	1.00	1.10
greater protective suit or	26.27	1.00	1.10
any anti-contamination	26.27	1.00	1.10
clothing is required	26.27	1.00	1.10
With supplied air respirator	27.27	1.00	1.10

**\*\* IMPORTANT NOTICE \*\***

Four (4), ten (10) hour days may be worked at straight time during a week, Monday thru Thursday. Friday may be used as a make-up day. Saturday may be used as a make-up day at time and one half of the hourly rate.

NOTE - In order to use the '4 Day/10 Hour Work schedule', as your normal schedule, you must submit an 'Employer Registration for Use of 4 Day/10 Hour Work Schedule,' form PW30.1; and there must be a dispensation of hours in place on the project. If the PW30.1 is not submitted you may be liable for overtime payments for work over 8 hours per day.

**SUPPLEMENTAL BENEFITS**

Per hour: \$ 17.27

**OVERTIME PAY**

See (B, E, E2, Q) on OVERTIME PAGE

**HOLIDAY**

Paid: See (1) on HOLIDAY PAGE  
 Overtime: See (5, 6) on HOLIDAY PAGE

**REGISTERED APPRENTICES**

Wages per hour:

1000 hour terms at the following percentage of Journeyman's wage:

1st	2nd	3rd	4th
70%	80%	85%	90%

Supplemental benefits per hour:

\$ 17.27

3-621b

**Laborer - Building** **08/01/2019**

**JOB DESCRIPTION** Laborer - Building

**DISTRICT** 3

**ENTIRE COUNTIES**

Erie

**PARTIAL COUNTIES**

Cattaraugus: Only the Townships of Perrysburg and the Village Gowanda.

**WAGES**

CLASS A: Basic, Safety Man, Flagman, Tool Room Man, Nurseryman, Demolition Worker, Top Man, Wrecker, IBC Barriers Except on Structures, Guard Rail, Asphalt Shovelers, Foundation Laborer over 8' in Depth, Hod Carriers, Plaster Tender, Plaster Scaffold Builder, Pneumatic Gas, Electric Tool Operator including all forms of Busters, Jackhammers and Chipping Guns, Steel Burners.

CLASS B: Mortar Mixer, Asphalt Smoothers, Pneumatic Gas, Electric Tool Operator including all forms of Busters, Jackhammers and Chipping Guns over 8' in depth.

CLASS C: Worker on any Swing Scaffold, Blaster, Plumbing Laborer, Wagon Drill Operator, Bottomman (caisson or cofferdam), Laser Setter, Asphalt Rakers, Asphalt Screed Man.

CLASS D: Stone Cutter, Curb Setter and Flag Layer.

CLASS E: Wearing of replaceable cartridge respirator.

CLASS F: Asbestos Removal, Deleader.

CLASS G: Hazardous Waste Worker.

Per hour:	07/01/2019	07/01/2020
Building Laborer:		Additional
CLASS A	\$ 27.88	\$ 1.75
CLASS B	28.05	1.75
CLASS C	28.16	1.75
CLASS D	28.63	1.75
CLASS E	28.88	1.75
CLASS F	29.38	1.75
CLASS G	29.88	1.75

**SUPPLEMENTAL BENEFITS**

Per hour: \$ 25.90

**OVERTIME PAY**

See (B, E, E2, Q) on OVERTIME PAGE

**HOLIDAY**

Paid: See (22) on HOLIDAY PAGE  
 Overtime: See (5, 6) on HOLIDAY PAGE

**REGISTERED APPRENTICES**

Wages per hour:

Hour terms at the following percentage of Journeyman's wage:

0 to 500 to 1000 to 1500 to 2000 to 2500 to 3000 to 4000  
 55% 60% 65% 70% 75% 80% 90%

Supplemental benefits per hour:

\$ 25.90

3-210b

**Laborer - Heavy&Highway**

**08/01/2019**

**JOB DESCRIPTION** Laborer - Heavy&Highway

**DISTRICT 3**

**ENTIRE COUNTIES**

Allegany, Cattaraugus

**PARTIAL COUNTIES**

Chautauqua: Only the Townships of Busti, Carroll, Chautauqua, Clymer, Ellery, Ellicott, Ellington, French Creek, Gerry, Harmony, Kiantone, Mina, North Harmony, Poland, Sherman, Stockton and the City of Jamestown.

**WAGES**

GROUP A: Basic, Drill Helper, Flagman, Outboard and Hand Boats. Chain Saw, Concrete Aggregate Bin, Concrete Bootmen, Gin Buggy, Hand or Machine Vibrator, Jack Hammer, Mason Tender, Mortar Mixer, Pavement Breaker, Handlers of Steel Mesh, Small Generators for Laborers' Tools, Pipe Layers, Vibrator Type Rollers, Tamper, Drill Doctor, Water Pump Operator (2" and Single Diaphragm), Nozzle (Asphalt, Guniting, Seeding, and Sand Blasting), Laborers on Chain Link Fence Erection, Rock Splitter and Power Unit, Pusher Type Concrete Saw and all other Gas, Electric, Oil and Air Tool Operators, Wrecking Laborer, Grade Checker.

GROUP B: All Rock or Drilling Machine Operators (Except Quarry Master and Similar Type), Acetylene Torch Operators and Powderman. Blasters, Curb and Flatwork Formsetters not on structures, Stone or Granite Curb Setters, Designated Asphalt Rakers (not on cold patch), Tail or Screw Operator on Asphalt Paver.

Per hour:	07/01/2019	07/01/2020	07/01/2021
		Additional	Additional
GROUP A	\$ 27.84	\$1.50	\$1.50
GROUP B	28.24	\$1.50	\$1.50

Hazardous waste removal, lead abatement, asbestos abatement add \$ 1.50

**SUPPLEMENTAL BENEFITS**

Per hour:

\$ 22.15

**OVERTIME PAY**

See (B, E, Q) on OVERTIME PAGE

**HOLIDAY**

Paid: See (5, 6) on HOLIDAY PAGE

Overtime: See (5, 6) on HOLIDAY PAGE

**REGISTERED APPRENTICES**

Wages per:

1000 hour terms at the following percentage of Journeyman's wage:

1st 2nd 3rd 4th  
 70% 80% 85% 90%

Supplemental benefits per hour:

\$ 22.15

3-621h Zone 1

**Lineman Electrician**

**08/01/2019**

**JOB DESCRIPTION** Lineman Electrician

**DISTRICT 6**

**ENTIRE COUNTIES**

Albany, Allegany, Broome, Cattaraugus, Cayuga, Chautauqua, Chemung, Chenango, Clinton, Columbia, Cortland, Delaware, Dutchess, Erie, Essex, Franklin, Fulton, Genesee, Greene, Hamilton, Herkimer, Jefferson, Lewis, Livingston, Madison, Monroe, Montgomery, Niagara, Oneida, Onondaga, Ontario, Orange, Orleans, Oswego, Otsego, Putnam, Rensselaer, Rockland, Saratoga, Schenectady, Schoharie, Schuyler, Seneca, St. Lawrence, Steuben, Sullivan, Tioga, Tompkins, Ulster, Warren, Washington, Wayne, Wyoming, Yates

**WAGES**

Per hour:

NOTE: Includes Teledata Work within ten (10) feet of High Voltage Transmission Lines

Below rates applicable on all overhead and underground distribution and maintenance work, and all overhead and underground transmission line work and the installation of fiber optic cable where no other construction trades are or have been involved. (Ref #14.01.01)

	07/01/2019	05/04/2020
Lineman, Technician	\$ 52.05	\$ 53.50
Crane, Crawler Backhoe	52.05	53.50
Welder, Cable Splicer	52.05	53.50
Digging Mach. Operator	46.85	48.15
Tractor Trailer Driver	44.24	45.48
Groundman, Truck Driver	41.64	42.80
Equipment Mechanic	41.64	42.80
Flagman	31.23	32.10

Additional \$1.00 per hour for entire crew when a helicopter is used.

Below rates applicable on all electrical sub-stations, switching structures, fiber optic cable and all other work not defined as "Utility outside electrical work". (Ref #14.02.01-A)

	07/01/2019	05/04/2020
Lineman, Technician	\$ 52.05	\$ 53.50
Crane, Crawler Backhoe	52.05	53.50
Cable Splicer	57.26	58.85
Certified Welder - Pipe Type Cable	54.65	56.18
Digging Mach. Operator	46.85	48.15
Tractor Trailer Driver	44.24	45.48
Groundman, Truck Driver	41.64	42.80
Equipment Mechanic	41.64	42.80
Flagman	31.23	32.10

Additional \$1.00 per hour for entire crew when a helicopter is used.

Below rates apply on switching structures, maintenance projects, railroad catenary install/maintenance third rail installation, bonding of rails and pipe type cable and installation of fiber optic cable. (Ref #14.02.01-B)

	07/01/2019	05/04/2020
Lineman, Tech, Welder	\$ 53.37	\$ 54.82
Crane, Crawler Backhoe	53.37	54.82
Cable Splicer	58.71	60.30
Certified Welder - Pipe Type Cable	56.04	57.56
Digging Mach. Operator	48.03	49.34
Tractor Trailer Driver	45.36	46.60
Groundman, Truck Driver	42.70	43.86
Equipment Mechanic	42.70	43.86
Flagman	32.02	32.89

Additional \$1.00 per hour for entire crew when a helicopter is used.

Below rates applicable on all overhead and underground transmission line work & fiber optic cable where other construction trades are or have been involved. This applies to transmission line work only, not other construction. (Ref #14.03.01)

	07/01/2019	05/04/2020
Lineman, Tech, Welder	\$ 54.56	\$ 56.01
Crane, Crawler Backhoe	54.56	56.01
Cable Splicer	54.56	56.01
Digging Mach. Operator	49.10	50.41
Tractor Trailer Driver	46.38	47.61
Groundman, Truck Driver	43.65	44.81
Equipment Mechanic	43.65	44.81
Flagman	32.74	33.61

Additional \$1.00 per hour for entire crew when a helicopter is used.

NOTE: THE FOLLOWING RATES WILL APPLY ON ALL CONTRACTING AGENCY MANDATED MULTIPLE SHIFTS OF AT LEAST FIVE (5) DAYS DURATION WORKED BETWEEN THE HOURS LISTED BELOW:

1ST SHIFT	8:00 AM to 4:30 PM REGULAR RATE
2ND SHIFT	4:30 PM to 1:00 AM REGULAR RATE PLUS 17.3 %
3RD SHIFT	12:30 AM to 9:00 AM REGULAR RATE PLUS 31.4 %

**\*\* IMPORTANT NOTICE \*\***

Four (4), ten (10) hour days may be worked at straight time during a week, Monday thru Thursday. Friday may be used as a make-up day.  
 \*Effective 05/06/2013, Tuesday thru Friday may be worked with no make-up day.

NOTE - In order to use the '4 Day/10 Hour Work schedule', as your normal schedule, you must submit an 'Employer Registration for Use of 4 Day/10 Hour Work Schedule,' form PW30.1; and there must be a dispensation of hours in place on the project. If the PW30.1 is not submitted you may be liable for overtime payments for work over 8 hours per day.

**SUPPLEMENTAL BENEFITS**

Per hour worked (also required on non-worked holidays):

The following SUPPLEMENTAL BENEFITS apply to all classification categories of CONSTRUCTION, TRANSMISSION and DISTRIBUTION.

Journeyman	\$ 24.15	\$ 24.90
	*plus 6.75% of hourly wage	*plus 6.75% of hourly wage

\*The 6.75% is based on the hourly wage paid, straight time rate or premium rate.

**OVERTIME PAY**

See (B, E, Q,) on OVERTIME PAGE. \*Note\* Double time for all emergency work designated by the Dept. of Jurisdiction.  
 NOTE: WAGE CAP...Double the straight time hourly base wage shall be the maximum hourly wage compensation for any hour worked.  
 Contractor is still responsible to pay the hourly benefit amount for each hour worked.

**HOLIDAY**

Paid See ( 5, 6, 8, 13, 25 ) on HOLIDAY PAGE plus Governor of NYS Election Day.  
 Overtime See ( 5, 6, 8, 13, 25 ) on HOLIDAY PAGE plus Governor of NYS Election Day.

NOTE: All paid holidays falling on Saturday shall be observed on the preceding Friday. All paid holidays falling on Sunday shall be observed on the following Monday. Supplements for holidays paid at straight time.

**REGISTERED APPRENTICES**

WAGES: 1000 hour terms at the following percentage of the applicable Journeyman Lineman wage.

1st	2nd	3rd	4th	5th	6th	7th
60%	65%	70%	75%	80%	85%	90%

SUPPLEMENTAL BENEFITS: Same as Journeyman

6-1249a

**Lineman Electrician - Teledata**

**08/01/2019**

**JOB DESCRIPTION** Lineman Electrician - Teledata

**DISTRICT 6**

**ENTIRE COUNTIES**

Albany, Allegany, Broome, Cattaraugus, Cayuga, Chautauqua, Chemung, Chenango, Clinton, Columbia, Cortland, Delaware, Dutchess, Erie, Essex, Franklin, Fulton, Genesee, Greene, Hamilton, Herkimer, Jefferson, Lewis, Livingston, Madison, Monroe, Montgomery, Niagara, Oneida, Onondaga, Ontario, Orange, Orleans, Oswego, Otsego, Putnam, Rensselaer, Rockland, Saratoga, Schenectady, Schoharie, Schuyler, Seneca, St. Lawrence, Steuben, Sullivan, Tioga, Tompkins, Ulster, Warren, Washington, Wayne, Westchester, Wyoming, Yates

**WAGES**

Per hour:

For outside work, stopping at first point of attachment (demarcation).

	07/01/2019	01/01/2020	01/01/2021
Cable Splicer	\$ 32.78	\$ 33.77	\$ 34.78
Installer, Repairman	\$ 31.12	\$ 32.05	\$ 33.01

Teledata Lineman	\$ 31.12	\$ 32.05	\$ 33.01
Tech., Equip. Operator	\$ 31.12	\$ 32.05	\$ 33.01
Groundman	\$ 16.49	\$ 16.99	\$ 17.50

NOTE: EXCLUDES Teledata work within ten (10) feet of High Voltage (600 volts and over) transmission lines. For this work please see LINEMAN.

NOTE: THE FOLLOWING RATES WILL APPLY ON ALL CONTRACTING AGENCY MANDATED MULTIPLE SHIFTS OF AT LEAST FIVE (5) DAYS DURATION WORKED:

1ST SHIFT	REGULAR RATE
2ND SHIFT	REGULAR RATE PLUS 10%
3RD SHIFT	REGULAR RATE PLUS 15%

**SUPPLEMENTAL BENEFITS**

Per hour:

Journeyman	\$ 4.73	\$ 4.73	\$ 4.73
	*plus 3% of wage paid	*plus 3% of wage paid	*plus 3% of wage paid

\*The 3% is based on the hourly wage paid, straight time rate or premium rate.

**OVERTIME PAY**

See (B, E, Q) on OVERTIME PAGE

NOTE: WAGE CAP...Double the straight time hourly base wage shall be the maximum hourly wage compensation for any hour worked. Contractor is still responsible to pay the hourly benefit amount for each hour worked.

**HOLIDAY**

Paid: See (1) on HOLIDAY PAGE  
 Overtime: See (5, 6, 16) on HOLIDAY PAGE

6-1249LT - Teledata

**Lineman Electrician - Traffic Signal, Lighting** **08/01/2019**

**JOB DESCRIPTION** Lineman Electrician - Traffic Signal, Lighting **DISTRICT 6**

**ENTIRE COUNTIES**

Albany, Allegany, Broome, Cattaraugus, Cayuga, Chautauqua, Chemung, Chenango, Clinton, Cortland, Delaware, Erie, Essex, Franklin, Fulton, Genesee, Greene, Hamilton, Herkimer, Jefferson, Lewis, Livingston, Madison, Monroe, Montgomery, Niagara, Oneida, Onondaga, Ontario, Orleans, Oswego, Otsego, Rensselaer, Saratoga, Schenectady, Schoharie, Schuyler, Seneca, St. Lawrence, Steuben, Sullivan, Tioga, Tompkins, Warren, Washington, Wayne, Wyoming, Yates

**WAGES**

Lineman/Technician shall perform all overhead aerial work. A Lineman/Technician on the ground will install all electrical panels, connect all grounds, install and connect all electrical conductors which includes, but is not limited to road loop wires; conduit and plastic or other type pipes that carry conductors, flex cables and connectors, and to oversee the encasement or burial of such conduits or pipes.

A Groundman/Groundman Truck Driver shall: Build and set concrete forms, handle steel mesh, set footer cages, transport concrete in a wheelbarrow, hand or machine concrete vibrator, finish concrete footers, mix mortar, grout pole bases, cover and maintain footers while curing in cold weather, operate jack hammer, operate hand pavement breaker, tamper, concrete and other motorized saws, as a drill helper, operate and maintain generators, water pumps, chainsaws, sand blasting, operate mulching and seeding machine, air tools, electric tools, gas tools, load and unload materials, hand shovel and/or broom, prepare and pour mastic and other fillers, assist digger operator equipment operator in ground excavation and restoration, landscape work and painting. Only when assisting a lineman technician, a groundman/groundman truck driver may assist in installing conduit, pipe, cables and equipment.

A flagger's duties shall consist of traffic control only.  
 (Ref #14.01.01)

Per hour:

	07/01/2019	05/04/2020
Lineman, Technician	\$ 45.00	\$ 46.20
Crane, Crawler Backhoe	45.00	46.20
Certified Welder	47.25	48.51
Digging Machine	40.50	41.58
Tractor Trailer Driver	38.25	39.27
Groundman, Truck Driver	36.00	36.96
Equipment Mechanic	36.00	36.96
Flagman	27.00	27.72



Above rates applicable on all Lighting and Traffic Signal Systems with the installation, testing, operation, maintenance and repair of all traffic control and illumination projects, traffic monitoring systems, road weather information systems and the installation of Fiber Optic Cable.

NOTE: THE FOLLOWING RATES WILL APPLY ON ALL CONTRACTING AGENCY MANDATED MULTIPLE SHIFTS OF AT LEAST FIVE (5) DAYS DURATION WORKED BETWEEN THE HOURS LISTED BELOW:

1ST SHIFT	8:00 AM TO 4:30 PM	REGULAR RATE
2ND SHIFT	4:30 PM TO 1:00 AM	REGULAR RATE PLUS 17.3%
3RD SHIFT	12:30 AM TO 9:00 AM	REGULAR RATE PLUS 31.4%

**\*\* IMPORTANT NOTICE \*\***

Four (4), ten (10) hour days may be worked at straight time during a week, Monday thru Thursday. Friday may be used as a make-up day.  
\*Effective 05/06/2013, Tuesday thru Friday may be worked with no make-up day.

NOTE - In order to use the '4 Day/10 Hour Work schedule', as your normal schedule, you must submit an 'Employer Registration for Use of 4 Day/10 Hour Work Schedule,' form PW30.1; and there must be a dispensation of hours in place on the project. If the PW30.1 is not submitted you may be liable for overtime payments for work over 8 hours per day.

**SUPPLEMENTAL BENEFITS**

Per hour worked (but also required on non-worked holidays):

Journeyman	\$ 24.15	\$ 24.90
	*plus 6.75% of hourly wage	*plus 6.75% of hourly wage

\*The 6.75% is based on the hourly wage paid, straight time rate or premium rate.  
Supplements paid at STRAIGHT TIME rate for holidays.

**OVERTIME PAY**

See (B, E, Q) on OVERTIME PAGE. \*Note\* Double time for all emergency work designated by the Dept. of Jurisdiction.  
NOTE: WAGE CAP...Double the straight time hourly base wage shall be the maximum hourly wage compensation for any hour worked.  
Contractor is still responsible to pay the hourly benefit amount for each hour worked.

**HOLIDAY**

Paid: See ( 5, 6, 8, 13, 25 ) on HOLIDAY PAGE plus Governor of NYS Election Day.  
Overtime: See ( 5, 6, 8, 13, 25 ) on HOLIDAY PAGE plus Governor of NYS Election Day.

NOTE: All paid holidays falling on Saturday shall be observed on the preceding Friday. All paid holidays falling on Sunday shall be observed on the following Monday. Supplements for holidays paid at straight time.

**REGISTERED APPRENTICES**

WAGES: Per hour. 1000 hour terms.

	07/01/2019	05/04/2020
1st term	\$ 27.00	\$ 27.72
2nd term	29.25	30.03
3rd term	31.50	32.34
4th term	33.75	34.65
5th term	36.00	36.96
6th term	38.25	39.27
7th term	40.50	41.58

SUPPLEMENTAL BENEFITS: Same as Journeyman

6-1249a-LT

**Lineman Electrician - Tree Trimmer**

**08/01/2019**

**JOB DESCRIPTION** Lineman Electrician - Tree Trimmer

**DISTRICT 6**

**ENTIRE COUNTIES**

Albany, Allegany, Broome, Cattaraugus, Cayuga, Chautauqua, Chemung, Chenango, Clinton, Columbia, Cortland, Delaware, Dutchess, Erie, Essex, Franklin, Fulton, Genesee, Greene, Hamilton, Herkimer, Jefferson, Lewis, Livingston, Madison, Monroe, Montgomery, Niagara, Oneida, Onondaga, Ontario, Orange, Orleans, Oswego, Otsego, Putnam, Rensselaer, Rockland, Saratoga, Schenectady, Schoharie, Schuyler, Seneca, St. Lawrence, Steuben, Sullivan, Tioga, Tompkins, Ulster, Warren, Washington, Wayne, Wyoming, Yates

**WAGES**

Per hour:

Applies to line clearance, tree work and right-of-way preparation on all new or existing energized overhead or underground electrical, telephone and CATV lines. This also would include stump removal near underground energized electrical lines, including telephone and CATV lines.

07/01/2019

Tree Trimmer	\$ 25.79
Equipment Operator	22.81
Equipment Mechanic	22.81
Truck Driver	18.99
Groundman	15.64
Flag person	11.27

**SUPPLEMENTAL BENEFITS**

Per hour worked (but also required on non-worked holidays):

Journeyman	\$ 9.98
	*plus 3% of hourly wage

\* The 3% is based on the hourly wage paid, straight time rate or premium rate.

**OVERTIME PAY**

See (B, E, Q) on OVERTIME PAGE

NOTE: WAGE CAP...Double the straight time hourly base wage shall be the maximum hourly wage compensation for any hour worked. Contractor is still responsible to pay the hourly benefit amount for each hour worked.

**HOLIDAY**

Paid: See (5, 6, 8, 15, 16, 25) on HOLIDAY PAGE  
 Overtime: See (5, 6, 8, 15, 16, 25) on HOLIDAY PAGE

NOTE: All paid holidays falling on a Saturday shall be observed on the preceding Friday.  
 All paid holidays falling on a Sunday shall be observed on the following Monday.

6-1249TT

**Mason - Building**

**08/01/2019**

**JOB DESCRIPTION** Mason - Building

**DISTRICT 5**

**ENTIRE COUNTIES**

Chautauqua

**PARTIAL COUNTIES**

Allegany: Entire county except the Townships of Alfred, Almond, Andover and Burns.  
 Cattaraugus: Entire county except the Township of Perrysburg and the Village of Gowanda.

**WAGES**

Per hour:	07/01/2019	07/01/2020	07/01/2021
Building:		Additional	Additional
Bricklayer Cement	\$ 31.83	\$ 1.00	\$ 1.15
Mason, Plasterer, Stone			
Mason, Tuck Pointer			

Four (4), ten (10) hour days may be worked at straight time during a week, Monday thru Thursday. Friday may be used as a make-up day.

NOTE - In order to use the '4 Day/10 Hour Work Schedule,' as your normal schedule, you must submit an 'Employer Registration for Use of 4 Day/10 Hour Work Schedule,' form PW30.1; and there must be a dispensation of hours in place on the project. If the PW30.1 is not submitted you may be liable for overtime payments for work over 8 hours per day.

**SUPPLEMENTAL BENEFITS**

Per hour:

Journeyman	\$ 20.87
------------	----------

**OVERTIME PAY**

See (B,E,E2\*,Q) on OVERTIME PAGE

\*Note - Or other conditions beyond the employer's control such as fire or natural disaster.

**HOLIDAY**

Paid: See (1) on HOLIDAY PAGE  
 Overtime: See (5, 6) on HOLIDAY PAGE

**REGISTERED APPRENTICES**

Wages per hour:

One year terms at the following percentage of Journeyman's wage:

1st	2nd	3rd	4th
\$ 19.08	\$ 21.90	\$ 25.21	\$ 28.53

Supplemental benefits per hour:

1st	2nd	3rd	4th
\$ 12.46	\$ 14.93	\$ 16.91	\$ 18.88

5-3B - Jam - Z2

**Mason - Building**

**08/01/2019**

**JOB DESCRIPTION** Mason - Building

**DISTRICT 3**

**ENTIRE COUNTIES**

Erie, Niagara

**PARTIAL COUNTIES**

Cattaraugus: Only the Township of Perrysburg and the Village of Gowanda.

**WAGES**

Per hour:	07/01/2019
Plasterer	\$ 30.15

Additional \$3.00/hr for work on swing stage over 20 feet.

**SUPPLEMENTAL BENEFITS**

Per hour:	\$ 20.49
-----------	----------

**OVERTIME PAY**

Exterior work only See ( B, E, E2, Q ) on OVERTIME PAGE.

All other work See ( B, E, Q ) on OVERTIME PAGE.

**HOLIDAY**

Paid:	See (1) on HOLIDAY PAGE
Overtime:	See (5, 6) on HOLIDAY PAGE

**REGISTERED APPRENTICES**

Wages per hour:

Hour terms at the following dollar amounts:

0	to 1000	to 2000	to 3000	to 4000	to 4700	to 5400	to 6000	to 7000	to 8000
\$ 12.00	\$ 14.00	\$ 15.00	\$ 16.00	\$ 17.00	\$ 18.00	\$ 19.00	\$ 20.00	\$ 21.00	

Supplemental benefits per hour:

Hour terms at the following dollar amounts:

0	to 4000	to 4700	to 5400	to 6000	to 8000
\$ 2.50	\$ 3.50	\$ 4.50	\$ 5.50	\$ 7.50	

3-9-Pltr

**Mason - Building**

**08/01/2019**

**JOB DESCRIPTION** Mason - Building

**DISTRICT 5**

**ENTIRE COUNTIES**

Erie, Niagara

**PARTIAL COUNTIES**

Cattaraugus: Only the Township of Perrysburg and the Village of Gowanda.

**WAGES**

Per Hour:	07/01/2019
Building:	
Bricklayer	\$ 31.49
Stone Mason	31.49
Tuck Pointer	31.49

Four (4), ten (10) hour days may be worked at straight time during a week, Monday thru Thursday. Friday may be used as a make-up day.

NOTE - In order to use the '4 Day/10 Hour Work schedule', as your normal schedule, you must submit an 'Employer Registration for Use of 4 Day/10 Hour Work Schedule,' form PW30.1; and there must be a dispensation of hours in place on the project. If the PW30.1 is not submitted you may be liable for overtime payments for work over 8 hours per day.

**SUPPLEMENTAL BENEFITS**

Per hour:

Journeyman \$ 28.34

**OVERTIME PAY**

See (B,E,E2\*,Q) on OVERTIME PAGE

\*Note - Or other conditions beyond the employer's control such as fire or natural disaster.

**HOLIDAY**

Paid: See (1) on HOLIDAY PAGE  
 Overtime: See (5, 6) on HOLIDAY PAGE

**REGISTERED APPRENTICES**

Wages per hour:

1250 hour terms at the following wage:

1st	2nd	3rd	4th
\$ 24.87	\$ 25.39	\$ 27.12	\$ 29.63

Supplemental benefits per hour:

1st	2nd	3rd	4th
\$ 10.95	\$ 16.43	\$ 20.70	\$ 24.20

5-3B-Z3

**Mason - Building / Heavy&Highway**

**08/01/2019**

**JOB DESCRIPTION** Mason - Building / Heavy&Highway

**DISTRICT 3**

**ENTIRE COUNTIES**

Erie

**PARTIAL COUNTIES**

Cattaraugus: Only the Township of Perrysburg and the Village of Gowanda.

**WAGES**

Per hour: 07/01/2019 07/01/2020  
 Additional  
 Cement Mason \$ 30.00 \$ 1.25  
 Additional \$0.25 per hr for working scaffold or exterior scaffold 42' or higher.  
 Additional \$1.00 per hr when required to wear respirator.

**SUPPLEMENTAL BENEFITS**

Per hour: \$ 31.67

**OVERTIME PAY**

See (B, E, Q, V) on OVERTIME PAGE

**HOLIDAY**

Paid: See (1) on HOLIDAY PAGE  
 Overtime: See (5, 6) on HOLIDAY PAGE

**REGISTERED APPRENTICES**

Wages per hour:

750 hour terms at the following dollar amounts:

1st	2nd	3rd	4th	5th	6th
\$ 15.00	\$ 16.50	\$ 19.50	\$ 22.50	\$ 25.50	\$ 28.50

Supplemental benefits per hour:

1st	2nd	3rd	4th	5th	6th
\$ 8.41	\$ 11.36	\$ 11.23	\$ 14.42	\$ 16.47	\$ 19.69

3-111Erie

**Mason - Heavy&Highway**

**08/01/2019**

**JOB DESCRIPTION** Mason - Heavy&Highway

**DISTRICT 5**

**ENTIRE COUNTIES**

Allegany, Broome, Chautauqua, Chemung, Chenango, Cortland, Delaware, Genesee, Livingston, Monroe, Ontario, Orleans, Otsego, Schuyler, Seneca, Steuben, Tioga, Tompkins, Wayne, Wyoming, Yates

**PARTIAL COUNTIES**

Cattaraugus: Entire county except in the Township of Perrysburg and the Village of Gowanda only the Bricklayer classification applies.  
 Erie: Only the Bricklayer classification applies.

Niagara: Only the Bricklayer classification applies.

**WAGES**

Per hour:	07/01/2019	07/01/2020	07/01/2021
Heavy & Highway:		Additional	Additional
Cement Mason	\$ 31.28	\$ 1.00	\$ 1.15
Bricklayer	31.28		

Four (4), ten (10) hour days may be worked at straight time during a week, Monday thru Thursday. Friday may be used as a make-up day.

NOTE - In order to use the '4 Day/10 Hour Work schedule', as your normal schedule, you must submit an 'Employer Registration for Use of 4 Day/10 Hour Work Schedule,' form PW30.1; and there must be a dispensation of hours in place on the project. If the PW30.1 is not submitted you may be liable for overtime payments for work over 8 hours per day.

**SUPPLEMENTAL BENEFITS**

Per hour:

Journeyman \$ 22.23

**OVERTIME PAY**

See (B, E, E2, Q) on OVERTIME PAGE

**HOLIDAY**

Paid: See (1) on HOLIDAY PAGE  
 Overtime: See (5, 6) on HOLIDAY PAGE

**REGISTERED APPRENTICES**

Wages per hour:

1500 hour terms at the following percentage of Journeyman's wage:

1st	2nd	3rd	4th
50%	60%	70%	80%

Supplemental benefits per hour:

1st term	\$ 13.93
2nd - 4th term	22.23

5-3h

---

**Mason - Tile Finisher** **08/01/2019**

---

**JOB DESCRIPTION** Mason - Tile Finisher

**DISTRICT** 5

**ENTIRE COUNTIES**

Chautauqua

**PARTIAL COUNTIES**

Allegany: Entire County with the exception of the Towns of Alfred, Almond, Andover and Burns.  
 Cattaraugus: With the exception of the Township of Perrysburg and the Village of Gowanda.

**WAGES**

Per hour:	07/01/2019	07/01/2020	07/01/2021
Building:		Additional	Additional
Marble, Slate, Terrazzo and Tile Finisher	\$ 27.00	\$ 1.00	\$ 1.15

Four (4), ten (10) hour days may be worked at straight time during a week, Monday thru Thursday. Friday may be used as a make-up day.

NOTE - In order to use the '4 Day/10 Hour Work schedule', as your normal schedule, you must submit an 'Employer Registration for Use of 4 Day/10 Hour Work Schedule,' form PW30.1; and there must be a dispensation of hours in place on the project. If the PW30.1 is not submitted you may be liable for overtime payments for work over 8 hours per day.

**SUPPLEMENTAL BENEFITS**

Per hour: \$ 17.81

**OVERTIME PAY**

See (B,E,E2\*,Q) on OVERTIME PAGE

\*Note - Or other conditions beyond the employer's control such as fire or natural disaster.

**HOLIDAY**

Paid: See (1) on HOLIDAY PAGE  
 Overtime: See (5, 6) on HOLIDAY PAGE

**REGISTERED APPRENTICES**

Wages per hour:

1st and 2nd term 1200 hours and 3rd term 1300 hours at the following percentage of Journeyman's rate:

1st	2nd	3rd
\$ 18.03	\$ 21.37	\$ 22.28

Supplemental benefits per hour:

1st	2nd	3rd
\$ 8.78	\$ 9.94	\$ 13.53

5-3TF - Z2

---

**Mason - Tile Finisher****08/01/2019**

**JOB DESCRIPTION** Mason - Tile Finisher

**DISTRICT 5**

**ENTIRE COUNTIES**

Erie, Niagara, Orleans

**PARTIAL COUNTIES**

Cattaraugus: Only the Township of Perrysburg and the Village of Gowanda.

**WAGES**

Per hour: 07/01/2019

Building:

Marble, Slate, Terrazzo and Tile Finisher \$ 29.30

Four (4), ten (10) hour days may be worked at straight time during a week, Monday thru Thursday. Friday may be used as a make-up day.

NOTE - In order to use the '4 Day/10 Hour Work schedule', as your normal schedule, you must submit an 'Employer Registration for Use of 4 Day/10 Hour Work Schedule,' form PW30.1; and there must be a dispensation of hours in place on the project. If the PW30.1 is not submitted you may be liable for overtime payments for work over 8 hours per day.

**SUPPLEMENTAL BENEFITS**

Per hour: \$ 16.13

**OVERTIME PAY**

See (B,E,E2\*,Q) on OVERTIME PAGE

\*Note - Or other conditions beyond the employer's control such as fire or natural disaster.

**HOLIDAY**

Paid: See (1) on HOLIDAY PAGE  
Overtime: See (5, 6) on HOLIDAY PAGE

**REGISTERED APPRENTICES**

Wages per hour:

1200 hours 1st and 2nd term and 1300 hours 3rd term at the following wage:

1st	2nd	3rd
\$ 18.74	\$ 21.31	\$ 24.13

Supplemental benefits per hour:

1st	2nd	3rd
\$ 8.44	\$ 10.43	\$ 12.17

5-3TF - Z3

---

**Mason - Tile Setter****08/01/2019**

**JOB DESCRIPTION** Mason - Tile Setter

**DISTRICT 5**

**ENTIRE COUNTIES**

Erie, Niagara, Orleans

**PARTIAL COUNTIES**

Cattaraugus: Only in the Township of Perrysburg and the Village of Gowanda.

**WAGES**

Per hour: 07/01/2019

Building:

Marble, Slate, Terrazzo and Tile Setter \$ 31.97

Four (4), ten (10) hour days may be worked at straight time during a week, Monday thru Thursday. Friday may be used as a make-up day.

NOTE - In order to use the '4 Day/10 Hour Work schedule', as your normal schedule, you must submit an 'Employer Registration for Use of 4 Day/10 Hour Work Schedule,' form PW30.1; and there must be a dispensation of hours in place on the project. If the PW30.1 is not submitted you may be liable for overtime payments for work over 8 hours per day.

**SUPPLEMENTAL BENEFITS**

Per hour: \$ 27.36

**OVERTIME PAY**

See (B,E,E2\*,Q) on OVERTIME PAGE

\*Note - Or other conditions beyond the employer's control such as fire or natural disaster.

**HOLIDAY**

Paid: See (1) on HOLIDAY PAGE

Overtime: See (5, 6) on HOLIDAY PAGE

**REGISTERED APPRENTICES**

Wages per hour:

1250 hour terms at the following wage:

1st	2nd	3rd	4th
\$ 24.65	\$ 25.12	\$ 26.89	\$ 29.93

Supplemental benefits per hour:

1st	2nd	3rd	4th
\$ 10.87	\$ 16.35	\$ 20.53	\$ 23.45

5-3TS - Z3

**Mason - Tile Setter**

**08/01/2019**

**JOB DESCRIPTION** Mason - Tile Setter

**DISTRICT 5**

**ENTIRE COUNTIES**

Chautauqua

**PARTIAL COUNTIES**

Allegany: Entire County with the exception of the towns of Alfred, Almond, Andover and Burns.  
 Cattaraugus: With the exception of the Township of Perrysburg and the Village of Gowanda.

**WAGES**

Per hour:	07/01/2019	07/01/2020	07/01/2021
Building:		Additional	Additional
Marble, Slate, Terrazzo and Tile Setter	\$ 32.19	\$ 1.00	\$ 1.15

Four (4), ten (10) hour days may be worked at straight time during a week, Monday thru Thursday. Friday may be used as a make-up day.

NOTE - In order to use the '4 Day/10 Hour Work schedule', as your normal schedule, you must submit an 'Employer Registration for Use of 4 Day/10 Hour Work Schedule,' form PW30.1; and there must be a dispensation of hours in place on the project. If the PW30.1 is not submitted you may be liable for overtime payments for work over 8 hours per day.

**SUPPLEMENTAL BENEFITS**

Per hour:

Journeyman \$ 18.16

**OVERTIME PAY**

See (B,E,E2\*,Q) on OVERTIME PAGE

\*Note - Or other conditions beyond the employer's control such as fire or natural disaster.

**HOLIDAY**

Paid: See (1) on HOLIDAY PAGE

Overtime: See (5, 6) on HOLIDAY PAGE

**REGISTERED APPRENTICES**

Wages per hour:

One year terms at the following percentage of Joureyman's wage:

1st	2nd	3rd	4th
\$ 20.14	\$ 23.24	\$ 26.32	\$ 29.42

Supplemental benefits per hour:

1st	2nd	3rd	4th
\$ 9.99	\$ 11.95	\$ 13.92	\$ 15.88

5-3TS - Z2

**Millwright**

**08/01/2019**

**JOB DESCRIPTION** Millwright

**DISTRICT 7**

**ENTIRE COUNTIES**

Allegany, Broome, Cattaraugus, Cayuga, Chautauqua, Herkimer, Madison, Seneca, Tioga, Yates

**WAGES**

Per Hour	07/01/2019	07/01/2020
		Additional
Building	\$ 28.18	\$ 1.60
Heavy & Highway*	30.18	1.60

\*Effective 5/1/2019, all Heavy and Highway Millwright construction will be paid at the rate indicated above.

NOTE - ADDITIONAL PREMIUMS PAID FOR THE FOLLOWING WORK LISTED BELOW (amount subject to any overtime premiums):

- Certified Welders shall receive \$1.75 per hour in addition to the current Millwright's rate, provided he/she is directed to perform certified welding.
- On building projects, if a work site has been declared a hazardous site by the Owner and the use of protective gear (including, as a minimum, air purifying canister-type chemical respirators) are required, then that employee shall receive a \$1.50 premium per hour.
- H/H work performed on hazardous waste sites where employees are required to wear protective gear shall receive an additional \$2.00 per hour over the Millwright H/H rate for all hours worked on the day protective gear was worn
- An employee performing the work of a machinist shall receive \$2.00 per hour in addition to the current Millwright's rate. For the purpose of this premium to apply, a "machinist" is a person who uses a lathe, Bridgeport, milling machine or similar type of tool to make or modify parts.
- When performing work underground at 500 feet and below, the employee shall receive an additional \$0.50. This amount will increase to \$1.00 on 7/1/2020.

**SUPPLEMENTAL BENEFITS**

Per hour:

Journeyman \$ 22.05

**OVERTIME PAY**

See (B, E, \*E2, Q) on OVERTIME PAGE

\*Note - Saturday may be used as a make-up day and worked at the straight time rate of pay during a work week when conditions such as weather, power failure, fire, or natural disaster prevent the performance of work on a regular scheduled work day.

**HOLIDAY**

Paid: See (1) on HOLIDAY PAGE

Overtime: See (5, 6) on HOLIDAY PAGE

NOTE: Any holiday that falls on Sunday shall be observed the following Monday. Any holiday that falls on a Saturday shall be observed the preceding Friday.

**REGISTERED APPRENTICES**

WAGES: (1) year terms at the following percentage of Journeyman's wage.

1st	2nd	3rd	4th
60%	70%	80%	90%

SUPPLEMENTAL BENEFITS per hour worked:

Appr. 1st year	\$ 10.50
Appr. 2nd year	18.59
Appr. 3rd year	19.74
Appr. 4th year	20.90

7-1163 Zone 2

**Operating Engineer - Building**

**08/01/2019**

**JOB DESCRIPTION** Operating Engineer - Building

**DISTRICT 12**

**ENTIRE COUNTIES**

Cattaraugus, Chautauqua, Erie, Orleans, Wyoming

**PARTIAL COUNTIES**

Genesee: Only that portion of the county that lies west of a line down the center of Route 98 excluding that area that lies within the City of Batavia.



## WAGES

CLASS A: Air Hoist, All Boom Type Equipment, All Pans and Carry-Alls, Archer Hoist, Asphalt Curb and Gutter Machines, Asphalt Roller, Asphalt Spreader or Paver, Automatic Fine Grade Machine (CMI or similar, first and second operator), Backhoe and Pullhoe, Backhoe and Pullhoe (tractor mounted, rubber tired), Back Filling Machine, Belt Placer (CMI or similar type), Bending Machine (Pipe), Bituminous Spreader and Mixer, Blacktop Plants (Automated and Non-automated), Blast or Rotary Drill (Truck or Track Mounted), Blower for Burning Brush, Boiler (when used for power), Boom Truck (excluding pick-up and delivery), Boring Machine, Bulldozer, Cableway, Cage Hoist, Caisson Auger, Central Mix Plant (and all concrete batching plants), Cherry Picker, Concrete Cleaning Decontamination Machine Operator, Concrete Curb and Gutter Machine, Concrete Curing Machine, Concrete Cutters (Vermeer or Similar Type), Concrete Mixer (over 1/2 cu yd.), Concrete Pavement Spreaders and Finishers, Concrete Paver, Concrete Pump, Conveyor, Core Drill, Crane, Crusher, Decon of Equipment, Derrick, Dragline, Dredge, Drill Rig (Tractor Mounted), Dual Drum Paver, Electric Pump used in conjunction with Well Point Systems, Elevating Grader (self propelled or towed), Elevator, Excavator (all purpose, hydraulically operated), Farm Tractor with Accessories, Fine Grade Machine, Forklift, Front End Loader, Generator (10 outlets or more), Gradall, Grader, Grout or Guniting Machine, Head Tower, Heavy Equipment Robotics Operator/Mechanic, Helicopter (when used for hoisting), Hoist (one drum), Hoisting Engine, Horizontal Directional Drill Locator, Horizontal Directional Drill Operator, Hydraulic Boom, Hydraulic Hammer (self-propelled), Hydraulic Pipe Jack Machine (or similar type machine), Hydraulic Rock Expander (or similar type machine), Hydraulic System Pumps, Hydro Crane, Hydro Hammer (or similar type), Industrial Tractor, Jersey Spreader, Kolman Plant Loader (and similar type loaders), Laser Screed, Locomotive, Lubrication Truck, Maintenance Engineer, Maintenance, Lubrication Unit or Truck, Mine Hoist, Mixer for Stabilized Base (self-propelled), Monorail, Motorized Hydraulic Pin Puller, Motorized Hydraulic Seeder, Mucking Machine, Mulching Machine, Multiple Drum Hoist (more than one drum in use), Overhead Crane, Peine Crane (or similar type), Pile Driver, Plant Engineer, Pneumatic Mixer, Post Hole Digger and Driver, Power Broom, Pumpcrete, Push Button Hoist, Push or Snatch Cat, Quarry Master or equivalent, Road Widener, Rock Bit Sharpener (all types), Roller (all), Rolling Machine (pipe), Rotomill, Scissors Trucks, Lift, or Boom Lift of any type (when used for hoisting), Scoopmobile, Shovel, Sideboom, Skidsteer/Bobcat (Similar Type), Skimmer, Slip Form Paver (CMI or similar type), Snorkel/Vacuum Truck, Strato-Tower, Stump Chipping Machine, Tire Truck and Drivers performing tire repair (exclude outside vendor), Towed Roller, Tractor Drawn Belt-Type Grader/Loader, Tractor Shovel, Tractor with Towed Accessories, Tractor (when using winch power), Tractors, Trencher, Truck Crane, Truck Mechanic and Helper (exclude Teamsters when repairing their own trucks), Tunnel Shovel, Tube Finisher (CMI and similar type), Ultra High Pressure Waterjet Cutting Tool System Operator/Mechanic, Vacuum Blasting Machine Operator/Mechanic, Vibratory Compactor, Vibro Tamp, Well Drilling Machine, Well Point, Winch, Winch Truck with A Frame.

CLASS B: Aggregate Bin, Aggregate Plant, Apprentice Engineer, Apprentice Engineer Driver, Articulated Off Road Material Hauler, Boiler (used in conjunction with production), CMI and similar type Concrete Spreads (Apprentice Engineer), Cement Bin, Chipping Machine and Chip Spreader, Compressors (4 or less), Compressors (any size, but subject to other provisions for Compressors, Dust Collectors, Generators, Mechanical Heaters, Pumps, Welding Machines - four of any type or combination), Concrete Mixer (1/2 cu. yd. and under), Fireman, Form Tamper, Form Trucks (excluding Teamster or delivery), Fuel Truck or Drivers (exclude Teamster or delivery), Heaters, Heating Boiler (used for temporary heat), Helper on Lubrication Unit or Truck, Jeep Trencher, Power Heaterman, Power Plant in excess of 10 K.W., Pumps, Revinus Widener, Steam Boilers (if manning or license by local law is required), Steam Cleaner (when used for cleaning equipment on the job site), Welding Machine (1 machine over 300 amps or 2 or 3 machines regardless of amps).

Operating Engineer- Building:

Per hour:	07/01/2019
Class A	\$ 37.21
Class B	32.73
Crane(Up to 60 Tons)	38.71
" (61 to 199 Tons)	40.71
" (200 to 399 Tons)	41.21
" (400 Tons or more)	41.71

Additional \$5.00/hr. for Any Tower Crane

Additional \$2.50/hr. for Hazardous Work Site

Additional \$1.00/hr. for Tunnel Work

## SUPPLEMENTAL BENEFITS

Per Hour:

Journeyman \$ 29.85\*\*

\*\*Note: For Overtime Hours \$21.65 of this amount is paid a straight time, the remaining balance of \$8.20 is paid at the same premium as the wage.

## OVERTIME PAY

See (B, E, \*E2, P, \*\*V) on OVERTIME PAGE

\* Only Saturdays between October 15th and April 15th.

## HOLIDAY

Paid: See (5, 6) on HOLIDAY PAGE

Overtime: See (5, 6) on HOLIDAY PAGE

## REGISTERED APPRENTICES

Wages per hour:

1 year Terms

1st	2nd	3rd	4th
\$27.05	\$27.94	\$28.82	\$29.71

Supplemental benefits Per Hour:  
 All Apprentices \$28.95\*\*

\*\*Note: For Overtime Hours \$21.65 of this amount to be paid a straight time rate  
 remaining balance of \$7.30 is paid at same premium as the wage.

12-17b

**Operating Engineer - Heavy&Highway** **08/01/2019**

**JOB DESCRIPTION** Operating Engineer - Heavy&Highway

**DISTRICT** 12

**ENTIRE COUNTIES**

Cattaraugus, Chautauqua, Erie, Orleans, Wyoming

**PARTIAL COUNTIES**

Genesee: Only that portion of the county that lies west of a line down the center of Route 98 excluding that area that lies within the City of Batavia.

**WAGES**

CLASS A: Air Hoist, All Boom Type Equipment, All Pans and Carry-Alls, Asphalt Curb and Cutter Machines, Asphalt Roller, Asphalt Spreader or Paver, Automatic Fine Grade Machine (CMI or similar, first and second operator), Backhoe and Pullhoe (all), Back Filling Machine, Belt Placer (CMI or similar type), Bending Machine (pipe), Bituminous Spreader and Mixer, Blacktop Plant (all), Blast or Rotary Drill (Truck or Track Mounted), Blower for Burning Brush, Boiler (when used for power), Boom Truck, Boring Machine, Bulldozer, Cableway, Cage Hoist, Caisson Auger, Central Mix Plant (and all Concrete Batching Plants), Cherry Picker, Concrete Cleaning Decontamination Machine, Concrete Curb and Gutter Machine, Concrete Curing Machine, Concrete Mixer (over 1/2 cu. yd.), Concrete Pavement Spreaders and Finishers, Concrete Paver, Concrete Pump, Concrete Saw (self propelled), Conveyor, Convoing Vehicles Convoing Engineer's Equipment, Core Drill, Crane, Crusher, Decontamination of Equipment, Derrick, Dragline, Dredge, Drill Rig (Tractor Mounted), Dual Drum Paver, Electric Pump used in conjunction with Well Point Systems, Elevating Grader (self propelled or towed), Elevator, Excavator (all purpose, hydraulically operated), Farm Tractor with Accessories, Fine Grade Machine, Forklift, Front End Loader, Gradall, Grader, Grout or Gunitite Machine, Head Tower, Heavy Equipment Robotics Operator/Mechanic, Hoist (all types), Hoisting Engine, Horizontal Directional Drill Locator, Horizontal Directional Drill Operator, Hydraulic Boom, Hydraulic Hammer (self propelled), Hydraulic Pipe Jack Machine, (or similar type machine), Hydraulic Rock Expander (or similar type machine), Hydraulic System Pumps, Industrial Tractor, Jersey Spreader, Kolman Plant Loader (and similar type Loaders), Laser Screed, Locomotive, Log Skidder (similar type), Maintenance Engineer, Maintenance, Lubrication Unit or Truck, Mine Hoist, Mixer for Stabilized Base (self propelled), Monorail, Motorized Hydraulic Pin Puller, Motorized Hydraulic Seeder, Mucking Machine, Mulching Machine, Overhead Crane, Parts Chasing, Peine Crane (or similar type), Pile Driver, Plant Engineer, Pneumatic Mixer, Post Hole Digger and Post Driver, Power Broom, Pump Crete, Push Button Hoist, Push or Snatch Cat, Quarry Master (or equivalent), Road Widener, Rock Bit Sharpener (all types), Roller (all), Rolling Machine (Pipe), Rotomill, Scoopmobile, Shovel, Side Boom, Skidsteer/Bobcat (similar type), Skimmer, Slip Form Paver (CMI or similar, first and second operator), Snorkel/Vacuum Truck, Strato-Tower, Tire Truck & Repair, Towed Roller, Tractor Drawn Belt-Type Grader/Loader, Tractor Shovel, Tractor with Towed Accessories, Tractors (when using winch power), Trencher, Truck Crane, Tug Boats, Tunnel Shovel, Tube Finisher (CMI and similar), Vacuum Blasting Machine Operator/Mechanic, Vibratory Compactor, Vibro Tamp, Waterjet Cutting Tool System Operator/Mechanic (Ultra High Pressure), Well Drilling Machine, Well Point, Winch, Winch Truck with A Frame.

CLASS B: Aggregate Bin, Aggregate Plant, Apprentice Engineer, Apprentice Engineer Driver, Articulated Off Road Material Hauler, CMI and similar type Concrete Spreads (Apprentice Engineer), Cement Bin, Chipping Machine and Chip Spreader, Compressors (4 or less), Compressors: any size, but subject to other provisions for Compressors, Dust Collectors, Generators, Mechanical Heaters, Pumps, Welding Machines (four of any type or combination), Concrete Mixer (1/2 cu. yd. and under), Fireman, Form Tamper, Fuel Truck, Heating Boiler (used for temporary heat), Helper on Lubrication Unit or Truck, Jeep Trencher, Power Heaterman, Power Plant in excess of 10 K.W., Pumps (4" or over), Revinus Widener, Steam Cleaner, Stump Chipping Machine, Welding Machine (1 machine over 300 amps or 2 or 3 machines regardless of amps).

Operating Engineer- Heavy/Highway, Sewer/Water, Tunnel:

Per hour:	07/01/2019
Class A	\$ 38.99
Class B	34.49
Crane(boom over 100ft)	39.74
" (boom over 200ft)	39.99
" (boom over 300ft)	40.49

- Additional \$3.00/hr. for Lattice Boom
- Additional \$3.00/hr. for Hydraulic Crane over 60 tons
- Additional \$2.50/hr. for Hazardous Work Site
- Additional \$1.00/hr. for Tunnel Work
- Additional \$3.00/hr. for Mandated Off-Shift Work

**SUPPLEMENTAL BENEFITS**

Per hour:

Journeyman \$ 31.16\*

\*Note: For Overtime Hours \$23.46 of the amount paid at straight time, the remaining balance of \$7.70 is paid at the same premium as the wage.

**OVERTIME PAY**

See (B, E, Q, T, \*V) on OVERTIME PAGE

**HOLIDAY**

Paid: See (\*5, \*\*6) on HOLIDAY PAGE

Overtime: See (\*\*5, \*\*\*\*6) on HOLIDAY PAGE

\*, \*\* NOTE: If Holiday falls on a Sunday it will be celebrated on Monday

\*\*\*, \*\*\*\* NOTE: If employee works that Monday use "T" under Overtime Pay.

**REGISTERED APPRENTICES**

Wages per hour:

Apprentices at 1 year terms

1st	2nd	3rd	4th
\$31.49	\$32.49	\$33.49	\$34.49

Supplemental Benefits

All Apprentices \$30.76\*

Note: For Overtime Hours \$23.46 of this amount is paid at straight time , the remaining balance of \$7.30 is paid at the same premium as the wage.

12-17 hh/sw/t

**Operating Engineer - Survey Crew**

**08/01/2019**

**JOB DESCRIPTION** Operating Engineer - Survey Crew

**DISTRICT** 12

**ENTIRE COUNTIES**

Cattaraugus, Chautauqua, Erie, Orleans, Wyoming

**PARTIAL COUNTIES**

Genesee: Only that portion of the county that lies west of a line down the center of Route 98 excluding that area that lies within the City of Batavia.

**WAGES**

These rates apply to Building and Heavy Highway.

Per hour:

SURVEY CLASSIFICATIONS:

Party Chief - One who directs a survey party.

Instrument Person - One who operates the surveying instruments.

Rod Person - One who holds the rods and assists the Instrument Person.

07/01/2019

Party Chief	\$ 41.51
Instrument Person	39.15
Rod Person	27.10

Additional \$3.00 per hr. for work in a Tunnel.

Additional \$2.50 per hr. for EPA or DEC certified toxic or hazardous waste work.

**SUPPLEMENTAL BENEFITS**

Per hour worked:

Journeyman \$ 26.80

**OVERTIME PAY**

See (B, E, P, T) on OVERTIME PAGE

**HOLIDAY**

Paid: See (5, 6) on HOLIDAY PAGE

Overtime: See (5, 6) on HOLIDAY PAGE

**REGISTERED APPRENTICES**

WAGES:1000 hour terms based on the Percentage of Rod Person wage:

07/01/2019

0-1000 Hrs	60%
1001-2000 Hrs	70%
2001-3000 Hrs	80%

SUPPLEMENTAL BENEFITS per hour worked:

0-1000 Hrs	\$ 16.21
1001-2000 Hrs	18.92
2001-3000 Hrs	21.63

12-17D Sur

**Operating Engineer - Survey Crew - Consulting Engineer**

**08/01/2019**

**JOB DESCRIPTION** Operating Engineer - Survey Crew - Consulting Engineer

**DISTRICT** 12

**ENTIRE COUNTIES**

Cattaraugus, Chautauqua, Erie, Orleans, Wyoming

**PARTIAL COUNTIES**

Genesee: Only that portion of the county that lies west of a line down the center of Route 98 excluding that area that lies within the City of Batavia.

**WAGES**

These rates apply to feasibility and preliminary design surveying, line of grade surveying for inspection or supervision of construction when performed under a Consulting Engineer Agreement.

Per hour:

SURVEY CLASSIFICATIONS:

Party Chief - One who directs a survey party.

Instrument Person - One who operates the surveying instruments.

Rod Person - One who holds the rods and assists the Instrument Person.

07/01/2019

Party Chief	\$ 41.51
Instrument Person	39.15
Rod Person	27.10

**SUPPLEMENTAL BENEFITS**

Per hour worked:

Journeyman	\$ 26.80
------------	----------

**OVERTIME PAY**

See (B, E, P, T) on OVERTIME PAGE

**HOLIDAY**

Paid: See (5, 6) on HOLIDAY PAGE

Overtime: See (5, 6) on HOLIDAY PAGE

**REGISTERED APPRENTICES**

WAGES: 1000 hour terms based on the Percentage of Rod Persons Wage:

07/01/2019

0-1000	60%
1001-2000	70%
2001-3000	80%

SUPPLEMENTAL BENEFITS per hour worked:

0-1000	\$ 16.21
1001-2000	18.92
2001-3000	21.63

12-17D Con Eng

**Painter**

**08/01/2019**

**JOB DESCRIPTION** Painter

**DISTRICT 3**

**ENTIRE COUNTIES**

Allegany, Erie, Genesee, Niagara, Orleans, Wyoming

**PARTIAL COUNTIES**

Cattaraugus: Entire County except the Townships of Conewango, Leon, Napoli, New Albion, Randolph and South Valley.

Chautauqua: Only the Townships of Awkright, Dunkirk, Hanover, Pomfret, Portland, Sheridan and Villenova.

Livingston: Only the Townships of North Dansville, Nunda, Ossian, Portage, Sparta, Spring Water and West Sparta.

Steuben: Only the Townships of Avoca, Canisteo, Cohocton, Dansville, Fremont, Greenwood, Hartsville, Hornellsville, Howard, Jasper, Prattsburg, Pulteney, Troupsburg, Tuscarora, Urbana, Wayland, Wayne, Woodhull, West Union, Wheeler, and the City of Hornell.

**WAGES**

Per hour:	07/01/2019	05/01/2020
		Additional
Basic Rate (Brush & Roll)	\$ 26.45	\$ 1.00
Spray painting, wallcovering	26.45	1.00
Abrasive and hydroblasting	26.45	1.00
Taping/DryWall Finisher	26.95	1.00
Skeleton Steel*	27.20	1.00

\* Skeleton Steel: No floors, walls or ceiling are constructed, including radio and television towers, flagpoles, smokestacks, cranes and the abatement of coatings with lead, asbestos and/or arsenic, etc. All work within the confines of a plant shall be paid the skeleton steel rate (except in-plant tank work (see Tank Rate)).

Four (4), ten (10) hour days may be worked at straight time during a week, Monday thru Thursday. Friday may be used as a make-up day.

NOTE - In order to use the '4 Day/10 Hour Work schedule', as your normal schedule, you must submit an 'Employer Registration for Use of 4 Day/10 Hour Work Schedule,' form PW30.1; and there must be a dispensation of hours in place on the project. If the PW30.1 is not submitted you may be liable for overtime payments for work over 8 hours per day.

**SUPPLEMENTAL BENEFITS**

Per hour:  
 \$ 25.34

**OVERTIME PAY**

Exterior work only See ( B, E4, F\*, R ) on OVERTIME PAGE.

All other work See ( B, F\*, R ) on OVERTIME PAGE.

\* Note - Saturday is payable at straight time if the employee misses work, except where a doctor's or hospital verification of illness is produced Monday through Friday when work was available to the employee.

**HOLIDAY**

Paid: See (1) on HOLIDAY PAGE  
 Overtime: See (5, 6) on HOLIDAY PAGE

**REGISTERED APPRENTICES**

Wages per hour:

Painter/Decorator: 750 hour terms at the following percentage of Journeyman's Basic wage rate:

1st	2nd	3rd	4th	5th	6th	7th	8th
50%	55%	60%	65%	70%	75%	80%	90%

Taper/Drywall Finisher: 750 hour terms at the following percentage of Journeyman's Taper wage:

1st	2nd	3rd	4th	5th	6th
50%	55%	60%	65%	75%	85%

Supplemental benefits per hour:

Painter/Decorator and Taper/Drywall Finisher:

1st	2nd	3rd	4th	5th	6th	7th	8th
\$ 2.30	\$ 4.30	\$ 5.30	\$ 5.80	\$ 6.30	\$ 6.80	\$ 7.30	\$ 7.55

3-4-Buf, Nia, Olean

**Painter**

**08/01/2019**

**JOB DESCRIPTION** Painter

**DISTRICT 3**

**ENTIRE COUNTIES**

Allegany, Broome, Cattaraugus, Cayuga, Chautauqua, Chemung, Chenango, Cortland, Delaware, Erie, Genesee, Herkimer, Jefferson, Lewis, Livingston, Madison, Monroe, Niagara, Oneida, Onondaga, Ontario, Orleans, Oswego, Otsego, Schuyler, Seneca, St. Lawrence, Steuben, Tioga, Tompkins, Wayne, Wyoming, Yates

**WAGES**

Per hour:	07/01/2019	05/01/2020
		Additional

Bridge	\$ 38.50	\$ 1.05
Tunnel	38.50	1.05
Tank*	36.50	1.05

For Bridge Painting Contracts, ALL WORKERS on and off the bridge (including Flagmen) are to be paid Painter's Rate; the contract must be ONLY for Bridge Painting.

Tank rate applies to indoor and outdoor tanks, tank towers, standpipes, digesters, waste water treatment tanks, chlorinator tanks, etc. Covers all types of tanks including but not limited to steel tanks, concrete tanks, fiberglass tanks, etc.

Note an additional \$2.00 per hour is required when the contracting agency or project specification requires any shift to start prior to 6:00am or after 12:00 noon.

**SUPPLEMENTAL BENEFITS**

Per hour: \$ 28.70

**OVERTIME PAY**

Exterior work only See ( B, E4, F\*, R ) on OVERTIME PAGE.

All other work See ( B, F\*, R ) on OVERTIME PAGE.

\*Note - Saturday is payable at straight time if the employee misses work, except where a doctor's or hospital verification of illness is produced Monday through Friday when work was available to the employee.

**HOLIDAY**

Paid: See (1) on HOLIDAY PAGE

Overtime: See (5, 6) on HOLIDAY PAGE

**REGISTERED APPRENTICES**

Wages per hour:

750 hour terms at the following percentage of Journeyman's wage rate:

1st	2nd	3rd	4th	5th	6th
50%	55%	60%	65%	75%	85%

Supplemental benefits per hour:

1st & 2nd terms	\$ 5.45
3rd & 4th terms	5.45
5th & 6th terms	6.45

3-4-Bridge, Tunnel, Tank

**Painter** **08/01/2019**

**JOB DESCRIPTION** Painter

**DISTRICT 3**

**ENTIRE COUNTIES**

**PARTIAL COUNTIES**

Cattaraugus: Only the Townships of Conewango, Leon, Napoli, New Albion, Randolph and South Valley.

Chautauqua: Only the Townships of Busti, Carroll, Charlotte, Chautauqua, Cherry Creek, Clymer, Ellery, Ellicott, Ellington, French Creek, Gerry, Harmony, Kiantone, Mina, North Harmony, Poland, Ripley, Sherman, Stockton, Westfield and the City of Jamestown.

**WAGES**

Per hour:	07/01/2019	05/01/2020
		Additional
Brush & Roller, taping,	\$ 26.15	\$ 1.00
wallcovering, swing & bosun	26.15	1.00
under 3 stories or under 35 ft	26.15	1.00
Swing & bosun over 3 stories or	26.40	1.00
over 35 feet, steel painting	26.40	1.00
All spraying, steam cleaning &	26.80	1.00
sandblasting, all toxic coating	26.80	1.00
Stacks	27.45	1.00

Four (4), ten (10) hour days may be worked at straight time during a week, Monday thru Thursday. Friday may be used as a make-up day.

NOTE - In order to use the '4 Day/10 Hour Work schedule', as your normal schedule, you must submit an 'Employer Registration for Use of 4 Day/10 Hour Work Schedule,' form PW30.1; and there must be a dispensation of hours in place on the project. If the PW30.1 is not submitted you may be liable for overtime payments for work over 8 hours per day.

**SUPPLEMENTAL BENEFITS**

Per hour:

\$ 18.08

**OVERTIME PAY**

Exterior work only See ( B, E4, F\*, R ) on OVERTIME PAGE.

All other work See ( B, F\*, R ) on OVERTIME PAGE.

\* Note - Saturday is payable at straight time if the employee misses work, except where a doctor's or hospital verification of illness is produced Monday through Friday when work was available to the employee.

**HOLIDAY**

Paid: See (1) on HOLIDAY PAGE

Overtime: See (5, 6) on HOLIDAY PAGE

**REGISTERED APPRENTICES**

Wages per hour:

Painter/Decorator: 750 hour terms at the following percentage of Journeyman's Basic wage rate:

1st	2nd	3rd	4th	5th	6th	7th	8th
50%	55%	60%	65%	70%	75%	80%	90%

Taper/Drywall Finisher: 750 hour terms at the following percentage of Journeyman's Taper wage:

1st	2nd	3rd	4th	5th	6th
50%	55%	60%	65%	75%	85%

Supplemental benefits per hour:

Painter/Decorator and Taper/Drywall Finisher:

1st	2nd	3rd	4th	5th	6th	7th	8th
\$ 2.30	\$ 4.30	\$ 5.30	\$ 5.80	\$ 6.30	\$ 6.80	\$ 7.30	\$ 7.55

3-4-Jamestown

**Painter - Metal Polisher**

**08/01/2019**

**JOB DESCRIPTION** Painter - Metal Polisher

**DISTRICT 8**

**ENTIRE COUNTIES**

Albany, Allegany, Bronx, Broome, Cattaraugus, Cayuga, Chautauqua, Chemung, Chenango, Clinton, Columbia, Cortland, Delaware, Dutchess, Erie, Essex, Franklin, Fulton, Genesee, Greene, Hamilton, Herkimer, Jefferson, Kings, Lewis, Livingston, Madison, Monroe, Montgomery, Nassau, New York, Niagara, Oneida, Onondaga, Ontario, Orange, Orleans, Oswego, Otsego, Putnam, Queens, Rensselaer, Richmond, Rockland, Saratoga, Schenectady, Schoharie, Schuyler, Seneca, St. Lawrence, Steuben, Suffolk, Sullivan, Tioga, Tompkins, Ulster, Warren, Washington, Wayne, Westchester, Wyoming, Yates

**WAGES**

	07/01/2019
Metal Polisher	\$ 30.58
Metal Polisher*	31.53
Metal Polisher**	34.08

\*Note: Applies on New Construction & complete renovation

\*\* Note: Applies when working on scaffolds over 34 feet.

**SUPPLEMENTAL BENEFITS**

Per Hour: 07/01/2019

Journeyworker:

All classification \$ 7.72

**OVERTIME PAY**

See (B, E, P, T) on OVERTIME PAGE

**HOLIDAY**

Paid: See (5, 6, 11, 15, 16, 25, 26) on HOLIDAY PAGE

Overtime: See (5, 6, 9, 11, 15, 16, 25, 26) on HOLIDAY PAGE

**REGISTERED APPRENTICES**

Wages per hour:

One (1) year term at the following wage rates:

07/01/2019

1st year	\$ 15.00
2nd year	15.00
3rd year	15.75

1st year*	\$ 17.39
2nd year*	17.44
3rd year*	18.29

1st year**	\$ 19.50
2nd year**	19.50
3rd year**	20.25

\*Note: Applies on New Construction & complete renovation

\*\* Note: Applies when working on scaffolds over 34 feet.

Supplemental benefits:

Per hour:

1st year	\$ 5.52
2nd year	5.52
3rd year	5.52

8-8A/28A-MP

---

**Plumber****08/01/2019**

---

**JOB DESCRIPTION** Plumber

**DISTRICT 3**

**ENTIRE COUNTIES**

Erie, Niagara, Wyoming

**PARTIAL COUNTIES**

Allegheny: Only the Townships of Allen, Angelica, Belfast, Caneadea, Centerville, Granger, Hume, New Hudson and Rushford  
Cattaraugus: Only the Townships of Ashford, Dayton, East Otto, Ellicottville, Farmersville, Franklinville, Freedom, Leon, Lyndon, Machias, Mansfield, New Albion, Otto, Perrysburg, Persia and Yorkshire.  
Chautauqua: Only the Townships of Arkwright, Charlotte, Cherry Creek, Dunkirk, Hanover, Pomfret, Portland, Ripley, Sheridan, Stockton, Villenova, Westfield, City of Dunkirk and Village of Fredonia.  
Genesee: Only the Townships of Alabama, Alexander, Batavia, Darien, Elba, Oakfield, Pembroke and the City of Batavia.  
Orleans: Only the Townships of Ridgeway, Shelby and Yates.

**WAGES**

Per hour: 07/01/2019

Plumber	\$ 35.60
Steamfitter	\$ 35.60

Note - Add 10% (ten-percent) to wage when HAZMAT training is required or when OSHA compliant respirator protection is required.

**SUPPLEMENTAL BENEFITS**

Per hour:

\$ 25.86

Note - \$3.40 of this amount must be paid at the same premium as the wage.

**OVERTIME PAY**

See (\*B, \*\*E, Q) on OVERTIME PAGE

\* Double time after 11 hours per day on Weekdays.

\*\* Double time after 10 hours per day on Saturday.

**HOLIDAY**

Paid: See (1) on HOLIDAY PAGE

Overtime: See (5, 6, 16) on HOLIDAY PAGE

**REGISTERED APPRENTICES**

Wages per hour:

One year terms at the following percentage of Journeyman's wage:

1st	2nd	3rd	4th	5th
45%	55%	65%	75%	90%

Note - Add 10% (ten-percent) to wage when HAZMAT training is required or when OSHA compliant respirator protection is required.

Supplemental benefits per hour:

\$ 21.30

Note - \$3.40 of this amount must be paid at the same premium as the wage.

3-22-Buffalo, Niagara

---

**Plumber****08/01/2019**

---

**JOB DESCRIPTION** Plumber

**DISTRICT 3**

**ENTIRE COUNTIES**



**PARTIAL COUNTIES**

Allegany: Only the Townships of Alma, Amity, Bolivar, Clarksville, Cuba, Friendship, Genesee, Wirt and that portion of Scio which lies west of Rt. 19.

Cattaraugus: Only the Townships of Allegany, Carrollton, Conewango, Cold Spring, Great Valley, Hinsdale, Humphrey, Ischua, Little Valley, Napoli, Olean, Portville, Randolph, Red House, Salamanca, South Valley, the City of Olean, the City of Salamanca, and the Allegany Indian Reservation.

Chautauqua: Only the Townships of Busti, Carroll, Chautauqua, Clymer, Ellery, Ellicott, Ellington, French Creek, Gerry, Harmony, Kiantone, Mina, North Harmony, Poland, Sherman, and the City of Jamestown.

**WAGES**

Per hour: 07/01/2019

Plumber \$ 34.03  
Steamfitter \$ 34.03

Note - Add 10% (ten-percent) to wage when HAZMAT training is required or when OSHA compliant respirator protection is required.

**SUPPLEMENTAL BENEFITS**

Per hour: \$ 25.86

Note - \$3.40 of this amount must be paid at the same premium as the wage.

**OVERTIME PAY**

See (\*B, \*\*E, Q) on OVERTIME PAGE

\* Double time after 11 hours per day on Weekdays.

\*\* Double time after 10 hours per day on Saturday.

**HOLIDAY**

Paid: See (1) on HOLIDAY PAGE

Overtime: See (5, 6, 16) on HOLIDAY PAGE

**REGISTERED APPRENTICES**

Wages per hour:

One year terms at the following percentage of Journeyman's wage:

1st	2nd	3rd	4th	5th
45%	55%	65%	75%	90%

Note - Add 10% (ten-percent) to wage when HAZMAT training is required or when OSHA compliant respirator protection is required.

Supplemental benefits per hour:

\$ 21.30

Note - \$3.40 of this amount must be paid at the same premium as the wage.

3-22-Southern

**Roofer** **08/01/2019**

**JOB DESCRIPTION** Roofer

**DISTRICT 3**

**ENTIRE COUNTIES**

Allegany, Cattaraugus, Chautauqua

**WAGES**

Per hour: 07/01/2019

Roofer \$ 31.00  
Waterproofer 31.00

Asbestos Removal with respirator or protective suit add \$1.00 per hour.

**SUPPLEMENTAL BENEFITS**

Per hour: \$ 13.95

**OVERTIME PAY**

See (B, E, E2, Q) on OVERTIME PAGE

**HOLIDAY**

Paid: See (1) on HOLIDAY PAGE

Overtime: See (5, 6) on HOLIDAY PAGE

**REGISTERED APPRENTICES**

Wages per hour:

750 hour terms at the following percentage of Journeyman's wage:

1st	2nd	3rd	4th	5th	6th
50%	50%	60%	70%	80%	90%

Supplemental benefits per hour:

1st & 2nd terms	\$ 0.58
All other terms	13.95

3-210

---

**Sheetmetal Worker** **08/01/2019**

---

**JOB DESCRIPTION** Sheetmetal Worker **DISTRICT 3**

**ENTIRE COUNTIES**  
 Cattaraugus, Chautauqua

**WAGES**

Per hour:	07/01/2019	07/01/2020	07/01/2021
Sheet Metal Worker	\$ 27.75	\$0.75	\$0.75

Additional \$1.00 per hour for work performed at a height of fifty (50) feet or more on boatswains chair, swing (of any type), picks and plank.

The following premiums apply when shift work is mandated in the job specification or by the contracting agency:

- 15% when the majority of the hours are worked between the hours of 3:30PM - 1:00AM
- 20% when the majority of the hours are worked between the hours of 11:00PM - 9:00AM

**SUPPLEMENTAL BENEFITS**

Per hour:	\$ 23.53
-----------	----------

**OVERTIME PAY**

See (B, E, Q) on OVERTIME PAGE

**HOLIDAY**

Paid: See (1) on HOLIDAY PAGE  
 Overtime: See (5, 6) on HOLIDAY PAGE

**REGISTERED APPRENTICES**

Wages per:

1000 hour year terms:

1st	2nd	3rd	4th	5th	6th	7th	8th
\$ 13.88	\$ 14.99	\$ 16.10	\$ 17.21	\$ 18.32	\$ 19.43	\$ 20.54	\$ 21.65

Supplemental Benefits

07/01/2019

1st term	\$ 13.29
2nd term	13.84
3rd term	16.04
4th term	16.70
5th term	17.36
6th term	18.02
7th term	18.68
8th term	19.33

3-112-Jamestown

---

**Sprinkler Fitter** **08/01/2019**

---

**JOB DESCRIPTION** Sprinkler Fitter **DISTRICT 1**

**ENTIRE COUNTIES**

Allegany, Broome, Cattaraugus, Cayuga, Chautauqua, Chemung, Chenango, Clinton, Columbia, Cortland, Delaware, Erie, Essex, Franklin, Fulton, Genesee, Greene, Hamilton, Herkimer, Jefferson, Lewis, Livingston, Madison, Monroe, Montgomery, Niagara, Oneida, Onondaga, Ontario, Orleans, Oswego, Otsego, Schoharie, Schuyler, Seneca, St. Lawrence, Steuben, Tioga, Tompkins, Washington, Wayne, Wyoming, Yates

**WAGES**

Per hour	07/01/2019
Sprinkler Fitter	\$ 34.91

**SUPPLEMENTAL BENEFITS**

Per hour

Journeyman \$ 24.93

**OVERTIME PAY**

See (B, E, Q) on OVERTIME PAGE

**HOLIDAY**

Paid: See (1) on HOLIDAY PAGE

Overtime: See (5, 6) on HOLIDAY PAGE

Note: When a holiday falls on Sunday, the following Monday shall be considered a holiday and all work performed on either day shall be at the double time rate. When a holiday falls on Saturday, the preceding Friday shall be considered a holiday and all work performed on either day shall be at the double time rate.

**REGISTERED APPRENTICES**

Wages per hour

For Apprentices HIRED ON OR AFTER 04/01/2010:

One Half Year terms at the following percentage of journeyman's wage.

1st	2nd	3rd	4th	5th	6th	7th	8th	9th	10th
45%	50%	55%	60%	65%	70%	75%	80%	85%	90%

Supplemental Benefits per hour worked

1st	2nd	3rd	4th	5th	6th	7th	8th	9th	10th
\$ 9.18	\$ 9.22	\$ 17.89	\$ 17.93	\$ 18.48	\$ 18.52	\$ 18.57	\$ 18.61	\$ 18.66	\$ 18.70

For Apprentices HIRED ON OR AFTER 04/01/2013:

One Half Year terms at the following percentage of journeyman's wage.

1st	2nd	3rd	4th	5th	6th	7th	8th	9th	10th
45%	50%	55%	60%	65%	70%	75%	80%	85%	90%

Supplemental Benefits per hour worked

1st	2nd	3rd	4th	5th	6th	7th	8th	9th	10th
\$ 8.27	\$ 8.27	\$ 18.04	\$ 18.04	\$ 18.29	\$ 18.29	\$ 18.29	\$ 18.29	\$ 18.29	\$ 18.29

1-669

**Teamster - Building / Heavy&Highway** **08/01/2019**

**JOB DESCRIPTION** Teamster - Building / Heavy&Highway

**DISTRICT** 3

**ENTIRE COUNTIES**

Cattaraugus, Chautauqua

**PARTIAL COUNTIES**

Allegany: Entire county except the Townships of Alfred, Almond, Burns and West Almond.

**WAGES**

GROUP 1: Warehousemen, Yardmen, Truck Helpers, Panel Trucks, Flatboy Material Trucks (straight jobs), Single Axle Dump Trucks, Dumpsters, Material Checkers and Receivers, Greasers, Truck Tiremen, Mechanics Helpers and Parts Chasers, Tandems and Batch Trucks, Mechanics, Dispatcher, Semi-Trailers, Low-boy Trucks, Asphalt Distributor Trucks, and Agitator, Mixer Trucks and Dumpcrete type vehicles, Truck Mechanic, Fuel Trucks.

GROUP 2: Specialized Earth Moving Equipment, Euclid type, or similar off-highway where not self-loading and self-contained concrete mobile unit, Off-highway Tandem Back-Dump, Twin Engine Equipment and Double-Hitched Equipment where not self-loading, Water Tanks, Sprinkler Trucks and Winch Trucks.

Per hour: 07/01/2019

GROUP 1 \$ 38.31

GROUP 2 38.31

Add \$ 2.00 when required to use personal protection when performing hazardous waste removal work.

Add \$ 2.00 while operating articulating truck.

**SUPPLEMENTAL BENEFITS**

Per hour: \$ 14.78

**OVERTIME PAY**  
See (B, E, Q) on OVERTIME PAGE

**HOLIDAY**  
Paid: See (5, 20) on HOLIDAY PAGE  
Overtime: See (5, 6) on HOLIDAY PAGE

3-264

---

**Welder** **08/01/2019**

---

**JOB DESCRIPTION** Welder **DISTRICT 1**

**ENTIRE COUNTIES**  
Albany, Allegany, Bronx, Broome, Cattaraugus, Cayuga, Chautauqua, Chemung, Chenango, Clinton, Columbia, Cortland, Delaware, Dutchess, Erie, Essex, Franklin, Fulton, Genesee, Greene, Hamilton, Herkimer, Jefferson, Kings, Lewis, Livingston, Madison, Monroe, Montgomery, Nassau, New York, Niagara, Oneida, Onondaga, Ontario, Orange, Orleans, Oswego, Otsego, Putnam, Queens, Rensselaer, Richmond, Rockland, Saratoga, Schenectady, Schoharie, Schuylar, Seneca, St. Lawrence, Steuben, Suffolk, Sullivan, Tioga, Tompkins, Ulster, Warren, Washington, Wayne, Westchester, Wyoming, Yates

**WAGES**  
Per hour 07/01/2019

Welder: To be paid the same rate of the mechanic performing the work.\*

\*EXCEPTION: If a specific welder certification is required, then the 'Certified Welder' rate in that trade tag will be paid.

**OVERTIME PAY**

**HOLIDAY**

1-As Per Trade

## Overtime Codes

Following is an explanation of the code(s) listed in the OVERTIME section of each classification contained in the attached schedule. Additional requirements may also be listed in the HOLIDAY section.

NOTE: Supplemental Benefits are 'Per hour worked' (for each hour worked) unless otherwise noted

- ( AA ) Time and one half of the hourly rate after 7 and one half hours per day
- ( A ) Time and one half of the hourly rate after 7 hours per day
- ( B ) Time and one half of the hourly rate after 8 hours per day
- ( B1 ) Time and one half of the hourly rate for the 9th & 10th hours week days and the 1st 8 hours on Saturday.  
Double the hourly rate for all additional hours
- ( B2 ) Time and one half of the hourly rate after 40 hours per week
- ( C ) Double the hourly rate after 7 hours per day
- ( C1 ) Double the hourly rate after 7 and one half hours per day
- ( D ) Double the hourly rate after 8 hours per day
- ( D1 ) Double the hourly rate after 9 hours per day
- ( E ) Time and one half of the hourly rate on Saturday
- ( E1 ) Time and one half 1st 4 hours on Saturday; Double the hourly rate all additional Saturday hours
- ( E2 ) Saturday may be used as a make-up day at straight time when a day is lost during that week due to inclement weather
- ( E3 ) Between November 1st and March 3rd Saturday may be used as a make-up day at straight time when a day is lost during that week due to inclement weather, provided a given employee has worked between 16 and 32 hours that week
- ( E4 ) Saturday and Sunday may be used as a make-up day at straight time when a day is lost during that week due to inclement weather
- ( E5 ) Double time after 8 hours on Saturdays
- ( F ) Time and one half of the hourly rate on Saturday and Sunday
- ( G ) Time and one half of the hourly rate on Saturday and Holidays
- ( H ) Time and one half of the hourly rate on Saturday, Sunday, and Holidays
- ( I ) Time and one half of the hourly rate on Sunday
- ( J ) Time and one half of the hourly rate on Sunday and Holidays
- ( K ) Time and one half of the hourly rate on Holidays
- ( L ) Double the hourly rate on Saturday
- ( M ) Double the hourly rate on Saturday and Sunday
- ( N ) Double the hourly rate on Saturday and Holidays
- ( O ) Double the hourly rate on Saturday, Sunday, and Holidays
- ( P ) Double the hourly rate on Sunday
- ( Q ) Double the hourly rate on Sunday and Holidays
- ( R ) Double the hourly rate on Holidays
- ( S ) Two and one half times the hourly rate for Holidays

- ( S1 ) Two and one half times the hourly rate the first 8 hours on Sunday or Holidays One and one half times the hourly rate all additional hours.
- ( T ) Triple the hourly rate for Holidays
- ( U ) Four times the hourly rate for Holidays
- ( V ) Including benefits at SAME PREMIUM as shown for overtime
- ( W ) Time and one half for benefits on all overtime hours.
- ( X ) Benefits payable on Paid Holiday at straight time. If worked, additional benefit amount will be required for worked hours. (Refer to other codes listed.)

## Holiday Codes

### PAID Holidays:

Paid Holidays are days for which an eligible employee receives a regular day's pay, but is not required to perform work. If an employee works on a day listed as a paid holiday, this remuneration is in addition to payment of the required prevailing rate for the work actually performed.

### OVERTIME Holiday Pay:

Overtime holiday pay is the premium pay that is required for work performed on specified holidays. It is only required where the employee actually performs work on such holidays. The applicable holidays are listed under HOLIDAYS: OVERTIME. The required rate of pay for these covered holidays can be found in the OVERTIME PAY section listings for each classification.

Following is an explanation of the code(s) listed in the HOLIDAY section of each classification contained in the attached schedule. The Holidays as listed below are to be paid at the wage rates at which the employee is normally classified.

- ( 1 ) None
- ( 2 ) Labor Day
- ( 3 ) Memorial Day and Labor Day
- ( 4 ) Memorial Day and July 4th
- ( 5 ) Memorial Day, July 4th, and Labor Day
- ( 6 ) New Year's, Thanksgiving, and Christmas
- ( 7 ) Lincoln's Birthday, Washington's Birthday, and Veterans Day
- ( 8 ) Good Friday
- ( 9 ) Lincoln's Birthday
- ( 10 ) Washington's Birthday
- ( 11 ) Columbus Day
- ( 12 ) Election Day
- ( 13 ) Presidential Election Day
- ( 14 ) 1/2 Day on Presidential Election Day
- ( 15 ) Veterans Day
- ( 16 ) Day after Thanksgiving
- ( 17 ) July 4th
- ( 18 ) 1/2 Day before Christmas
- ( 19 ) 1/2 Day before New Years
- ( 20 ) Thanksgiving
- ( 21 ) New Year's Day
- ( 22 ) Christmas
- ( 23 ) Day before Christmas
- ( 24 ) Day before New Year's
- ( 25 ) Presidents' Day
- ( 26 ) Martin Luther King, Jr. Day
- ( 27 ) Memorial Day
- ( 28 ) Easter Sunday







NEW YORK STATE DEPARTMENT OF LABOR  
Bureau of Public Work - Debarment List

**LIST OF EMPLOYERS INELIGIBLE TO BID ON OR BE  
AWARDED ANY PUBLIC WORK CONTRACT**

Under Article 8 and Article 9 of the NYS Labor Law, a contractor, sub-contractor and/or its successor shall be debarred and ineligible to submit a bid on or be awarded any public work or public building service contract/sub-contract with the state, any municipal corporation or public body for a period of five (5) years from the date of debarment when:

- Two (2) final determinations have been rendered within any consecutive six-year (6) period determining that such contractor, sub-contractor and/or its successor has WILLFULLY failed to pay the prevailing wage and/or supplements;
- One (1) final determination involves falsification of payroll records or the kickback of wages and/or supplements.

The agency issuing the determination and providing the information, is denoted under the heading 'Fiscal Officer'. DOL = New York State Department of Labor; NYC = New York City Comptroller's Office; AG = New York State Attorney General's Office; DA = County District Attorney's Office.

**Debarment Database:** To search for contractors, sub-contractors and/or their successors debarred from bidding or being awarded any public work contract or subcontract under NYS Labor Law Articles 8 and 9, or under NYS Workers' Compensation Law Section 141-b, access the database at this link: <https://applications.labor.ny.gov/EDList/searchPage.do>

**For inquiries where WCB is listed as the "Agency", please call 1-866-546-9322**

**NYSDOL Bureau of Public Work Debarment List 07/22/2019**

**Article 8**

AGENCY	Fiscal Officer	FEIN	EMPLOYER NAME	EMPLOYER DBA NAME	ADDRESS	DEBARMENT START DATE	DEBARMENT END DATE
DOL	DOL	*****0996	A-1 CONSTRUCTION & RENOVATION INC		1973 81ST ST - SUITE A-5 BROOKLYN NY 11214	01/08/2015	01/08/2020
DOL	NYC		ABDUL KARIM		C/O NORTH AMERICAN IRON W 1560 DECATUR STREETRIDGEWOOD NY 11385	05/15/2015	05/15/2020
DOL	DOL	*****4539	ACCOMPLISHED WALL SYSTEMS INC		112 OSCAWANNA HEIGHTS RD PUTNAM VALLEY NY 10542	03/13/2015	03/12/2020
DOL	DOL	*****3344	ACT INC		6409 LAND O LAKES BLVD LAND O LAKES FL 34638	11/10/2015	11/10/2020
DOL	DOL	*****4018	ADIRONDACK BUILDING RESTORATION INC.		4156 WILSON ROAD EAST TABERG NY 13471	03/26/2019	03/26/2024
DOL	DOL	*****1687	ADVANCED SAFETY SPRINKLER INC		261 MILL ROAD P.O BOX 296EAST AURORA NY 14052	07/29/2015	07/29/2020
DOL	DOL	*****1687	ADVANCED SAFETY SPRINKLER INC		261 MILL ROAD P.O BOX 296EAST AURORA NY 14052	05/29/2019	05/29/2024
DOL	NYC	*****6775	ADVENTURE MASONRY CORP.		1535 RICHMOND AVENUE STATEN ISLAND NY 10314	12/13/2017	12/13/2022
DOL	DOL		AJ TORCHIA		10153 ROBERTS RD SAUQUOIT NY 13456	08/09/2016	08/09/2021
DOL	DOL	*****3344	ALL CATASTROPHE CONSTRUCTION TEAM INC	ACT INC	6409 LAND O LAKES BLVD LAND O LAKES FL 34638	11/10/2015	11/10/2020
DOL	DOL	*****8740	ALLSTATE ENVIRONMENTAL CORP		C/O JOSE MONTAS 27 BUTLER PLACEYONKERS NY 10710	03/18/2011	03/19/2020
DOL	DOL		AMADEO J TORCHIA	TORCHIA'S HOME IMPROVEMENT	10153 ROBERTS RD SAUQUOIT NY 13456	08/09/2016	08/09/2021
DOL	DOL		ANGELO F COKER			12/04/2018	12/04/2023
DOL	NYC		ANISUL ISLAM		C/O RELIANCE GENERAL CONS 644 OCEAN PARKWAYBROOKLYN NY 11230	09/02/2015	09/02/2020
DOL	DOL		ANITA SALERNO		158 SOLAR ST SYRACUSE NY 13204	01/07/2019	01/07/2024
DOL	DOL	*****7004	ANNEX CONTRACTING LTD		3005 WYNSUM AVENUE MERRICK NY 11566	08/18/2014	08/18/2019
DOL	DOL	*****7004	ANNEX GENERAL CONTRACTING INC		3005 WYNSUM AVENUE MERRICK NY 11566	08/18/2014	08/18/2019
DOL	DA		ANTHONY CARDINALE		58-48 59TH STREET MASPETH NY 11378	05/16/2012	05/08/2020
DOL	DOL		ANTHONY J MINGARELLI JR		C/O T & T CONCRETE INC 2560 HAMBURG TURNPIKELACKAWANNA NY 14218	07/08/2015	07/08/2020
DOL	DOL		ANTHONY PERGOLA		3 WEST MAIN ST/SUITE 208 ELMSFORD NY 10323	01/23/2017	01/23/2022
DOL	DOL		ANTONIO ESTIVEZ		442 ARMONK RD MOUNT KISCO NY 10549	06/12/2018	06/12/2023
DOL	DOL	*****3020	APCO CONTRACTING CORP		24 SOUTH MARYLAND AVENUE PORT WASHINGTON NY 11050	09/24/2012	09/02/2020
DOL	NYC	*****9232	ARKAY CONSTRUCTION INC		102-104 GREYLOCK AVENUE BELLEVILLE NJ 07109	07/15/2015	07/15/2020
DOL	NYC	*****4779	ASTORIA GENERAL CONTRACTING CORP		35-34 31ST STREET LONG ISLAND CITY NY 11106	09/02/2015	09/02/2020
DOL	NYC	*****7217	ASTRO COMMUNICATIONS OF NY CORP		79 ALEXANDER AVE- STE 36A BRONX NY 10454	10/30/2015	10/30/2020
DOL	NYC	*****6046	ATLANTIC SUN CONSTRUCTION CORP		58-46 59TH AVENUE MASPETH NY 11378	05/08/2015	05/08/2020
DOL	NYC	*****6683	ATLAS RESTORATION CORP.		35-12 19TH AVENUE ASTORIA NY 11105	08/02/2017	08/02/2022
DOL	NYC		AUDLEY O'BRIEN		1273 NORTH AVENUE/#1 CP NEW ROCHELLE NY 10804	04/07/2015	04/07/2020
DOL	NYC	*****2591	AVI 212 INC.		260 CROPSEY AVENUE APT 11BROOKLYN NY 11214	10/30/2018	10/30/2023
DOL	DOL		AVIS R HILL		3510 HICKORY WALK LANE ELLENWOOD GA 32094	01/22/2015	01/22/2020

**NYSDOL Bureau of Public Work Debarment List 07/22/2019**

**Article 8**

DOL	AG		AVTAR SINGH		116-24 127TH STREET SOUTH OZONE PARK NY 11420	12/22/2015	12/22/2020
DOL	AG		BALDEV SINGH		116-24 127TH STREET SOUTH OZONE PARK NY 11420	12/22/2015	12/22/2020
DOL	NYC		BALWINDER SINGH		421 HUDSON ST SUITE C5NEW YORK NY 10014	02/20/2019	02/20/2024
DOL	DOL		BARBARA CASSIDY		7 BLENIS PLACE VALHALLA NY 10595	04/02/2015	04/02/2020
DOL	DOL		BARRY KINNEY		6409 LAND O LAKES BLVD LAND O LAKES FL 34638	11/10/2015	11/10/2020
DOL	NYC	*****3915	BEACON RESTORATION INC		SUITE B-8 782 PELHAM PARKWAY SOUTHBRONX NY 10462	04/21/2016	04/21/2021
DOL	NYC	*****8416	BEAM CONSTRUCTION, INC.		50 MAIN ST WHITE PLAINS NY 10606	01/04/2019	01/04/2024
DOL	DOL		BIAGIO CANTISANI			06/12/2018	06/12/2023
DOL	DOL	*****4512	BOB BRUNO EXCAVATING, INC		5 MORNINGSIDE DR AUBURN NY 13021	05/28/2019	05/28/2024
DOL	DOL		BOGDAN MARKOVSKI		370 W. PLEASANTVIEW AVE SUITE 2.329HACKENSACK NJ 07601	02/11/2019	02/11/2024
DOL	DOL	*****8551	BRANDY'S MASONRY		216 WESTBROOK STREET P O BOX 304SAYRE PA 18840	08/09/2016	08/09/2021
DOL	NYC	*****6555	BROOKLYN WELDING CORP		1273 NORTH AVENUE/ #1 CP NEW ROCHELLE NY 10804	04/07/2015	04/07/2020
DOL	DOL	*****1449	BRRESTORATION NY INC		140 ARCADIA AVENUE OSWEGO NY 13126	09/12/2016	09/12/2021
DOL	DOL		BRUCE MORSEY		C/O KENT HOLLOW SIDING LL 29A BRIDGE STREETNEW MILFORD CT 06776	01/15/2016	01/15/2021
DOL	DOL		BRUCE P. NASH JR.		5841 BUTTERNUT ROAD EAST SYRACUSE NY 13057	09/12/2018	09/12/2023
DOL	DOL	*****8809	C.B.E. CONTRACTING CORPORATION		310 MCGUINESS BLVD GREENPOINT NY 11222	03/07/2017	03/07/2022
DOL	DOL	*****9383	C.C. PAVING AND EXCAVATING, INC.		2610 SOUTH SALINA ST SUITE 12SYRACUSE NY 13205	12/04/2018	12/04/2023
DOL	DOL		CANTISANI & ASSOCIATES LTD		442 ARMONK RD MOUNT KISCO NY 10549	06/12/2018	06/12/2023
DOL	DOL		CANTISANI HOLDING LLC			06/12/2018	06/12/2023
DOL	DOL		CARIBBEAN POOLS		C/O DOUGLAS L MALARKEY 64 VICTORIA DRIVEBINGHAMTON NY 13904	02/04/2016	02/04/2021
DOL	DOL	*****3812	CARMODY "2" INC			06/12/2018	06/12/2023
DOL	DOL	*****1143	CARMODY BUILDING CORP	CARMODY CONTRACTIN G AND CARMODY CONTRACTIN G CORP.	442 ARMONK RD MOUNT KISCO NY 10549	06/12/2018	06/12/2023
DOL	DOL		CARMODY CONCRETE CORPORATION			06/12/2018	06/12/2023
DOL	DOL		CARMODY ENTERPRISES, LTD.		442 ARMONK RD MOUNT KISCO NY 10549	06/12/2018	06/12/2023
DOL	DOL		CARMODY INC		442 ARMONK RD MOUNT KISCO NY 10549	06/12/2018	06/12/2023
DOL	DOL	*****3812	CARMODY INDUSTRIES INC			06/12/2018	06/12/2023
DOL	DOL		CARMODY MAINTENANCE CORPORATION		442 ARMONK RD MOUNT KISCO NY 10549	06/12/2018	06/12/2023
DOL	DOL		CARMODY MASONRY CORP		442 ARMONK RD MOUNT KISCO NY 10549	06/12/2018	06/12/2023
DOL	NYC	*****9172	CASSIDY EXCAVATING INC		14 RAILROAD AVENUE VALHALLA NY 10595	05/15/2014	04/02/2020
DOL	DOL	*****6745	CATSKILL FENCE INSTALLATIONS INC		5445 ROUTE 32 CATSKILL NY 12414	08/22/2014	08/22/2019
DOL	DOL	*****8809	CBE CONTRACTING CORP		142 EAST MARKET STREET LONG BEACH NY 11561	03/07/2017	03/07/2022
DOL	AG		CESAR J. AGUDELO		81-06 34TH AVENUE APT. 6EJACKSON HEIGHTS NY 11372	02/07/2018	02/07/2023
DOL	DOL	*****7655	CHAMPION CONSTRUCTION SERVICES CORP		2131 SCHENECTADY AVENUE BROOKLYN NY 11234	11/18/2015	11/18/2020

**NYS DOL Bureau of Public Work Debarment List 07/22/2019**

**Article 8**

DOL	NYC		CHARLES CASSIDY JR		14 RAILROAD AVENUE VALHALLA NY 10595	05/15/2014	04/02/2020
DOL	DOL		CHARLES ZIMMER JR		216 WESTBROOK STREET P O BOX 304 SAYRE PA 18840	08/09/2016	08/09/2021
DOL	DOL		CHRISTINE J HEARNE		C/O CJ-HEARNE CONSTRUCTIO 131 PONCE DE LEON AVE NEATLANTA GA 30308	12/01/2015	12/01/2020
DOL	DOL		CHRISTOPHER J MAINI		19 CAITLIN AVE JAMESTOWN NY 14701	09/17/2018	09/17/2023
DOL	DOL		CHRISTOPHER PAPASTEFANO A/K/A CHRIS PAPASTEFANO		1445 COMMERCE AVE BRONX NY 10461	05/30/2019	05/30/2024
DOL	DOL	*****0671	CJ-HEARNE CONSTRUCTION CO		SUITE 204 131 PONCE DE LEON AVENUE ATLANTA GA 30308	12/01/2015	12/01/2020
DOL	DOL	*****1927	CONSTRUCTION PARTS WAREHOUSE, INC.	CPW	5841 BUTTERNUT ROAD EAST SYRACUSE NY 13057	09/12/2018	09/12/2023
DOL	NYC	*****4468	CRAFT CONTRACTING GROUP INC		3256 BRUNER AVENUE BRONX NY 10469	07/29/2014	07/29/2019
DOL	NYC	*****8507	CRAFT FENCE INC		3256 BRUNER AVENUE BRONX NY 10469	07/29/2014	07/29/2019
DOL	NYC	*****2164	CREATIVE TRUCKING INC		58-83 54TH STREET MASPETH NY 11378	02/26/2016	02/26/2021
DOL	DOL	*****2524	CSI ELECTRICAL & MECHANICAL INC		42-32 235TH ST DOUGLSTON NY 11363	01/14/2019	01/14/2024
DOL	DOL	*****7761	D L MALARKEY CONSTRUCTION		64 VICTORIA DRIVE BINGHAMTON NY 13904	02/04/2016	02/04/2021
DOL	DOL	*****7888	D L MALARKEY CONSTRUCTION INC		64 VICTORIA DRIVE BINGHAMTON NY 13904	02/04/2016	02/04/2021
DOL	DOL	*****5629	DAKA PLUMBING AND HEATING LLC		2561 ROUTE 55 POUGHQUAG NY 12570	02/19/2016	02/19/2021
DOL	DOL		DANICA IVANOSKI		61 WILLET ST. PASSAIC NJ 07503	10/26/2016	10/26/2021
DOL	DOL		DARIAN L COKER		2610 SOUTH SALINA ST SUITE 2C SYRACUSE NY 13205	12/04/2018	12/04/2023
DOL	DOL		DARYL T RIEKS		C/O RIEKS CONTRACTING LLC 4804 GAHWILER ROAD AUBURN NY 13021	05/01/2015	05/01/2020
DOL	NYC	*****7707	DASSLE CONTRACTING INC		213-37 39TH AVE/SUITE 120 BAYSIDE NY 11360	05/08/2015	05/08/2020
DOL	DOL		DAVID MARTINEZ		C/O EMPIRE TILE INC 6 TREMONT COURTHUNTINGTON STATION NY 11746	03/08/2016	03/08/2021
DOL	DOL		DEBBIE STURDEVANT		29 MAPLEWOOD DRIVE BINGHAMTON NY 13901	02/21/2017	02/21/2022
DOL	AG		DEBRA MARTINEZ		31 BAY ST BROOKLYN NY 11231	03/28/2018	03/28/2023
DOL	DOL		DEDA GAZIVODAN		C/O DAKA PLUMBING AND H 2561 ROUTE 55 POUGHQUAG NY 12570	02/19/2016	02/19/2021
DOL	DOL		DELPHI PAINTING & DECORATING CO INC		1445 COMMERCE AVE BRONX NY 10461	05/30/2019	05/30/2024
DOL	DOL		DENNIS SCHWANDTNER		C/O YES SERVICE AND REPAI 145 LODGE AVE HUNTINGTON STATION NY 11476	08/09/2016	08/09/2021
DOL	DOL		DF CONTRACTORS OF ROCHESTER, INC.		1835 DAANSEN RD. PALMYRA NY 14522	05/16/2017	05/16/2022
DOL	DOL		DF CONTRACTORS, INC.		1835 DAANSEN RD. PALMYRA NY 14522	05/16/2017	05/16/2022
DOL	NYC		DIMITRIOS KOUTSOUKOS		C/O ASTORIA GENERAL CONTR 35-34 31ST STREET LONG ISLAND CITY NY 11106	09/02/2015	09/02/2020
DOL	NYC		DIMITRIOS TSOUMAS		35-12 19TH AVENUE ASTORIA NY 11105	08/02/2017	08/02/2022
DOL	DOL	*****3242	DONALD R. FORSAY	DF LAWN SERVICE	1835 DAANSEN RD. PALMYRA NY 14522	05/16/2017	05/16/2022
DOL	DOL		DONALD R. FORSAY		1835 DAANSEN RD. PALMYRA NY 14522	05/16/2017	05/16/2022
DOL	DOL		DORIS SKODA		C/O APCO CONTRACTING CORP 24 SOUTH MARYLAND AVENUE PORT WASHINGTON NY 11050	09/24/2012	09/02/2020
DOL	NYC	*****7404	DOSANJH CONSTRUCTION CORP		9439 212TH STREET QUEENS VILLAGE NY 11428	02/25/2016	02/25/2021

**NYSDOL Bureau of Public Work Debarment List 07/22/2019**

**Article 8**

DOL	DOL		DOUGLAS L MALARKEY	MALARKEY CONSTRUCTION	64 VICTORIA DRIVE B INGHAMTON NY 13904	02/04/2016	02/04/2021
DOL	DOL		E C WEBB		6409 LAND O LAKES BLVD LAND O LAKES FL 34638	11/10/2015	11/10/2020
DOL	DOL		EARL L WILSON	WILSON BROTHER DRYWALL CONTRACTORS	36 ABERSOLD STREET ROCHESTER NY 14621	08/31/2015	08/31/2020
DOL	DOL		EAST COAST PAVING		2238 BAKER RD GILLET PA 16923	03/12/2018	03/12/2023
DOL	DOL	*****0780	EMES HEATING & PLUMBING CONTR		5 EMES LANE MONSEY NY 10952	01/20/2002	01/20/3002
DOL	DOL	*****3270	EMPIRE TILE INC		6 TREMONT COURT HUNTINGTON STATION NY 11746	03/08/2016	03/08/2021
DOL	DOL	*****7403	F & B PAINTING CONTRACTING INC		2 PARKVIEW AVENUE HARRISON NY 10604	09/26/2016	09/26/2021
DOL	DOL		FAIGY LOWINGER		11 MOUNTAIN RD 28 VAN BUREN DRMONROE NY 10950	03/20/2019	03/20/2024
DOL	DOL		FAY MATTHEW		C/O CHAMPION CONSTRUCTION 2131 SCHENECTADY AVENUE BROOKLYN NY 11234	11/18/2015	11/18/2020
DOL	DOL		FAZIA GINA ALI-MOHAMMED	C/O CHAMPION CONSTRUCTION	2131 SCHENECTADY AVENUE BROOKLYN NY 11234	11/18/2015	11/18/2020
DOL	DOL		FRANK BENEDETTO		19 CATLIN AVE JAMESTOWN NY 14701	09/17/2018	09/17/2023
DOL	DOL		FRANK BENEDETTO		C/O F & B PAINTING CONTRA 2 PARKVIEW AVENUE HARRISON NY 10604	09/26/2016	09/26/2021
DOL	DOL	*****4722	FRANK BENEDETTO AND CHRISTOPHER J MAINI	B & M CONCRETE	19 CAITLIN AVE JAMESTOWN NY 14701	09/17/2018	09/17/2023
DOL	DOL		FRANK DEMARTINO		101-61 99TH STREET OZONE PARK NY 11416	02/15/2017	02/15/2022
DOL	DOL		FRANK DEMARTINO		101-61 99TH STREET OZONE PARK NY 11416	02/15/2017	02/15/2022
DOL	DOL		GABRIEL FRASSETTI			04/10/2019	04/10/2024
DOL	DOL		GALINDA ROTENBERG		C/O GMDV TRANS INC 67-48 182ND STREET FRESH MEADOWS NY 11365	06/24/2016	06/24/2021
DOL	DOL		GEOFF CORLETT		415 FLAGGER AVE #302STUART FL 34994	10/31/2018	10/31/2023
DOL	DA		GEORGE LUCEY		150 KINGS STREET BROOKLYN NY 11231	01/19/1998	01/19/2998
DOL	DOL		GIGI SCHNECKENBURGER		261 MILL RD EAST AURORA NY 14052	05/29/2019	05/29/2024
DOL	DOL	*****5674	GMDV TRANS INC		67-48 182ND STREET FRESH MEADOWS NY 11365	06/24/2016	06/24/2021
DOL	NYC		GREAT ESTATE CONSTRUCTION, INC.		327 STAGG ST BROOKLYN NY 11206	10/10/2017	10/10/2022
DOL	DOL		GREGORY S. OLSON		P.O BOX 100 200 LATTA BROOK PARKHORSEHEADS NY 14845	03/08/2018	03/08/2023
DOL	NYC	*****0346	H N H CONTRACTORS CORP		4558 BROADWAY # 6 NEW YORK NY 10040	08/04/2014	08/04/2019
DOL	NYC		HAMEEDUL HASAN		240 HOME STREET TEANECK NJ 07666	08/04/2014	08/04/2019
DOL	NYC		HARMEL SINGH		15 CLINTON LANE HICKSVILLE NY 11801	02/25/2016	02/25/2021
DOL	NYC		HAROLD KUEMMEL		58-83 54TH STREET MASPETH NY 11378	02/26/2016	02/26/2021
DOL	DOL		HENRY VAN DALRYMPLE		2663 LANTERN LANE ATLANTA GA 30349	12/01/2015	12/01/2020
DOL	DOL	*****6370	HILLIANO CONSTRUCTION & ELECTRICAL INC		354 MAGNOLIA STREET ROCHESTER NY 14611	01/22/2015	01/22/2020
DOL	DOL	*****8282	IDEMA DEVELOPMENT INC		91 COLLEGE AVENUE POUGHKEEPSIE NY 12603	12/04/2015	12/04/2020
DOL	DOL	*****8282	IDEMA GENERAL CONTRACTORS INC		91 COLLEGE AVENUE POUGHKEEPSIE NY 12603	12/04/2015	12/04/2020
DOL	DOL	*****7001	INTEGRATED CONSTRUCTION & POWER SYSTEMS INC		SUITE 100 2105 W GENESEE STREETS SYRACUSE NY 13219	01/06/2016	01/06/2021

**NYS DOL Bureau of Public Work Debarment List 07/22/2019**

**Article 8**

DOL	DOL	*****5131	INTEGRITY MASONRY, INC.	M&R CONCRETE	722 8TH AVE WATERVLIET NY 12189	06/05/2018	06/05/2023
DOL	DOL		IRENE KASELIS		32 PENNINGTON AVE WALDWICK NJ 07463	05/30/2019	05/30/2024
DOL	AG		J A M CONSTRUCTION CORP		SUITE 125 265 SUNRISE HIGHWAYROCKVILLE CENTRE NY 10457	04/07/2016	04/07/2021
DOL	DOL	*****4910	J V MAGIC TOUCH CORPORATION		94-25 57TH AVENUE, APT 5G ELMHURST NY 11373	01/12/2015	01/12/2020
DOL	DOL		J.A. HIRES CADWALLADER		P.O BOX 100 200 LATTA BROOK PARKHORSEHEADS NY 14845	03/08/2018	03/08/2023
DOL	DOL		JAMES B RHYNDERS		91 COLLEGE AVENUE POUGHKEEPSIE NY 12603	12/04/2015	12/04/2020
DOL	DOL		JAMES C. DELGIACCO		722 8TH AVE WATERVLIET NY 12189	06/05/2018	06/05/2023
DOL	DOL		JAMES E RHYNDERS		91 COLLEGE AVENUE POUGHKEEPSIE NY 12603	12/04/2015	12/04/2020
DOL	AG		JAMES FALCONE		SUITE 125 265 SUNRISE HIGHWAYROCKVILLE CENTRE NY 10457	04/07/2016	04/07/2021
DOL	DOL		JAMES LIACONE		9365 WASHINGTON ST LOCKPORT IL 60441	07/23/2018	07/23/2023
DOL	DOL		JAMES RACHEL		9365 WASHINGTON ST LOCKPORT IL 60441	07/23/2018	07/23/2023
DOL	DOL		JAMES RHYNDERS SR		91 COLLEGE AVENUE POUGHKEEPSIE NY 12603	12/04/2015	12/04/2020
DOL	DOL		JAMES SICKAU		3090 SHIRLEY ROAD NORTH COLLINS NY 14111	04/19/2011	07/08/2020
DOL	DOL		JASON W MILLIMAN		C/O ROCHESTER ACOUSTICAL P O BOX 799HILTON NY 14468	02/19/2016	02/19/2021
DOL	DOL	*****5368	JCH MASONRY & LANDSCAPING INC.		35 CLINTON AVE OSSINING NY 10562	09/12/2018	09/12/2023
DOL	NYC		JEFFREY CASSIDY		14 RAILROAD AVENUE VALHALLA NY 10595	05/15/2014	04/02/2020
DOL	DOL		JEROME LACITIGNOLA		C/O CATSKILL FENCE INSTAL 5445 ROUTE 32 CATSKILL NY 12414	08/22/2014	08/22/2019
DOL	DOL		JESSICA WHITESIDE		C/O BRRESTORATION NY INC 140 ARCADIA AVENUEOSWEGO NY 13126	09/12/2016	09/12/2021
DOL	AG		JOHN ANTHONY MASSINO		36-49 204TH STREET BAYSIDE NY 11372	02/07/2018	02/07/2023
DOL	DOL		JOHN F. CADWALLADER		200 LATTA BROOK PARK HORSEHEADS NY 14845	03/08/2018	03/08/2023
DOL	DOL	*****4612	JOHN F. CADWALLADER, INC.	THE GLASS COMPANY	P.O BOX 100 200 LATTA BROOK PARKHORSEHEADS NY 14845	03/08/2018	03/08/2023
DOL	AG	*****0600	JOHNCO CONTRACTING, INC.		36-49 204TH STREET BAYSIDE NY 11372	02/07/2018	02/07/2023
DOL	DOL		JON E DEYOUNG		261 MILL RD P.O BOX 296EAST AURORA NY 14052	07/29/2015	07/29/2020
DOL	DOL		JON E DEYOUNG		261 MILL RD P.O BOX 296EAST AURORA NY 14052	05/29/2019	05/29/2024
DOL	DOL		JORGE VILLALOBOS		94-25 57TH AVENUE - APT 5 ELMHURST NY 11373	01/12/2015	01/12/2020
DOL	DOL		JORI PEDERSEN		415 FLAGER AVE #302STUART FL 34994	10/31/2018	10/31/2023
DOL	DOL		JOSE CHUCHUCA		35 CLINTON AVE OSSINING NY 10562	09/12/2018	09/12/2023
DOL	DOL		JOSE MONTAS		27 BUTLER PLACE YONKERS NY 10710	03/18/2011	03/19/2020
DOL	AG		JOSEPH FALCONE		SUITE 125 265 SUNRISE HIGHWAYROCKVILLE CENTRE NY 10457	04/07/2016	04/07/2021
DOL	DOL	*****9273	JOSEPH M LOVETRO		P O BOX 812 BUFFALO NY 14220	08/09/2016	08/09/2021
DOL	NYC		JOSEPH MARTINO		1535 RICHMOND AVENUE STATEN ISLAND NY 10314	12/13/2017	12/13/2022
DOL	DOL		JOSEPH MARTONE		112 OSCAWANA HEIGHTS RD PUTNAM VALLEY NY 10542	03/13/2015	03/13/2020

**NYS DOL Bureau of Public Work Debarment List 07/22/2019**

**Article 8**

DOL	DOL		JUANA MARTINEZ		C/O LEAD CONSTRUCTION 27 BUTLER PLACE YONKERS NY 10710	03/19/2015	03/19/2020
DOL	DOL		JULIUS AND GITA BEHREND		5 EMES LANE MONSEY NY 10952	11/20/2002	11/20/3002
DOL	DOL	*****5062	K R F SITE DEVELOPMENT INC		375 LAKE SHORE DRIVE PUTNAM VALLEY NY 10579	01/23/2017	01/23/2022
DOL	DOL		KATIE BURDICK		2238 BAKER RD GILLETT PA 16923	03/12/2018	03/12/2023
DOL	DOL		KENNETH FIORENTINO		375 LAKE SHORE DRIVE PUTNAM VALLEY NY 10579	01/23/2017	01/23/2022
DOL	DOL	*****9732	KENT HOLLOW SIDING LLC		29A BRIDGE STREET NEW MILFORD CT 06776	01/15/2016	01/15/2021
DOL	DOL		KEVIN BABCOCK JR		P O BOX 46 THOMPSON RIDGE NY 10985	08/22/2014	08/22/2019
DOL	DOL		KEVIN M BABCOCK		P O BOX 46 THOMPSON RIDGE NY 10985	08/22/2014	08/22/2019
DOL	DOL		KIM SOROCENSKI		C/O SOLUTION MATTERS INC 198 NORWOOD ROADPORT JEFFERSON NY 11776	11/19/2015	11/19/2020
DOL	DOL	*****3490	L & M CONSTRUCTION/DRYWALL INC.		1079 YONKERS AVE YONKERS NY 10704	08/07/2018	08/07/2023
DOL	DA	*****8816	LAKE CONSTRUCTION AND DEVELOPMENT CORPORATION		150 KINGS STREET BROOKLYN NY 11231	08/19/1998	08/19/2998
DOL	DOL	*****6224	LAKESIDE FIRE SPRINKLERS LLC		125 CHAUTAUQUA AVENUE LAKEWOOD NY 14750	06/24/2015	06/24/2020
DOL	AG	*****4643	LALO DRYWALL, INC.		221 OLD FORD ROAD NEW PLATZ NY 12561	05/20/2016	05/20/2021
DOL	DOL	*****4505	LARAPINTA ASSOCIATES INC		29 MAPLEWOOD DRIVE BINGHAMTON NY 13901	02/21/2017	02/21/2022
DOL	DOL		LAURI MARTONE		112 OSCAWANA HEIGHTS RD PUTNAM VALLEY NY 10542	03/13/2015	03/13/2020
DOL	DOL		LAVERN GLAVE		161 ROBYN RD MONROE NY 10950	09/15/2014	09/15/2019
DOL	DOL		LAVERN GLAVE		161 ROBYN RD MONROE NY 10950	01/30/2018	01/30/2023
DOL	DOL	*****1364	LEAD CONSTRUCTION SERVICES INC		3 ALAN B SHEPARD PLACE YONKERS NY 10705	03/19/2015	03/19/2020
DOL	DOL	*****4388	LEN.J CONSTRUCTION, LLC		PO BOX 10007 ALBANY NY 12201	06/24/2016	09/19/2022
DOL	DOL	*****4388	LEN.J CONSTRUCTION, LLC		PO BOX 10007 ALBANY NY 12201	06/24/2016	09/19/2022
DOL	DOL	*****4388	LEN.J CONSTRUCTION, LLC		PO BOX 10007 ALBANY NY 12201	09/19/2017	09/19/2022
DOL	DOL	*****4388	LEN.J CONSTRUCTION, LLC		PO BOX 10007 ALBANY NY 12201	09/19/2017	09/19/2022
DOL	DOL	*****4388	LEN.J CONSTRUCTION, LLC		PO BOX 10007 ALBANY NY 12201	01/17/2017	09/19/2022
DOL	DOL	*****4388	LEN.J CONSTRUCTION, LLC		PO BOX 10007 ALBANY NY 12201	09/19/2017	09/19/2022
DOL	DOL	*****4388	LEN.J CONSTRUCTION, LLC		PO BOX 10007 ALBANY NY 12201	09/19/2017	09/19/2022
DOL	DOL	*****4388	LEN.J CONSTRUCTION, LLC		PO BOX 10007 ALBANY NY 12201	08/14/2017	09/19/2022
DOL	DOL		LEROY NELSON JR		PO BOX 10007 ALBANY NY 12201	09/19/2017	09/19/2022
DOL	DOL		LEROY NELSON JR		PO BOX 10007 ALBANY NY 12201	09/19/2017	09/19/2022
DOL	DOL		LEROY NELSON JR		PO BOX 10007 ALBANY NY 12201	09/19/2017	09/19/2022
DOL	DOL		LEROY NELSON JR		PO BOX 10007 ALBANY NY 12201	09/19/2017	09/19/2022
DOL	DOL		LEROY NELSON JR		PO BOX 10007 ALBANY NY 12201	08/14/2017	08/14/2022
DOL	DOL		LEROY NELSON JR		PO BOX 10007 ALBANY NY 12201	01/17/2017	09/19/2022
DOL	DOL		LINDSEY R CRILL		143 FILLMORE AVENUE BUFFALO NY 14210	01/08/2015	01/08/2020
DOL	DA	*****4460	LONG ISLAND GLASS & STOREFRONTS, LLC		4 MANHASSET TRL RIDGE NY 11961	09/06/2018	09/06/2023
DOL	AG	*****4216	LOTUS-C CORP.		81-06 34TH AVENUE APT. 6E JACKSON HEIGHTS NY 11372	02/07/2018	02/07/2023
DOL	AG		LUIS MARTINEZ	LALO DRYWALL	211 MAIN ST. NEW PALTZ NY 12561	05/20/2016	05/20/2021

**NYSDOL Bureau of Public Work Debarment List 07/22/2019**

**Article 8**

DOL	DOL		M ANVER BEIG		142 EAST MARKET STREET LONG BEACH NY 11561	03/07/2017	03/07/2022
DOL	AG	*****6957	M B DIN CONSTRUCTION INC		8831 20TH AVENUE/SUITE 6E BROOKLYN NY 11214	11/17/2015	11/17/2020
DOL	NYC	*****6317	M S QUALITY CONSTRUCTION LLC		27 MAPLEWOOD AVENUE COLONIA NJ 07067	02/04/2015	02/04/2020
DOL	DOL		M. ANVER BEIG		142 EAST MARKET STREET LONG BEACH NY 11561	03/07/2017	03/07/2022
DOL	NYC		MACIEJ SONTOWSKI		27 MAPLEWOOD AVENUE COLONIA NJ 07067	02/04/2015	02/04/2020
DOL	NYC	*****9590	MACK GLASSNAUTH IRON WORKS INC		137 LIBERTY AVENUE BROOKLYN NY 11212	12/21/2015	12/21/2020
DOL	DOL	*****1784	MADISON AVE CONSTRUCTION CORP		39 PENNY STREET WEST ISLIP NY 11795	11/02/2016	11/02/2021
DOL	DOL		MALARKEY'S BAR & GRILL LLC		64 VICTORIA DRIVE BINGHAMTON NY 13904	02/04/2016	02/04/2021
DOL	DOL	*****0705	MALARKEY'S PUB & GRUB LLC		64 VICTORIA DRIVE BINGHAMTON NY 13904	02/04/2016	02/04/2021
DOL	DA		MANUEL P TOBIO		150 KINGS STREET BROOKLYN NY 14444	08/19/1998	08/19/2998
DOL	DA		MANUEL TOBIO		150 KINGS STREET BROOKLYN NY 11231	08/19/1998	08/19/2998
DOL	NYC		MAREK FABIJANOWSKI		50 MAIN ST WHITE PLAINS NY 10606	01/04/2019	01/04/2024
DOL	DOL		MARIACHI'S PIZZERIA		C/O DOUGLAS L MALARKEY 64 VICTORIA DRIVEBINGHAMTON NY 13904	02/04/2016	02/04/2021
DOL	DOL		MARK MIONIS		6409 LAND O LAKES BLVD LAND O LAKES FL 34638	11/10/2015	11/10/2020
DOL	DOL		MARVIN A STURDEVANT		29 MAPLEWOOD DRIVE BINGHAMTON NY 13901	02/21/2017	02/21/2022
DOL	DOL		MASONRY CONSTRUCTION, INC.		442 ARMONK RD MOUNT KISCO NY 10549	06/12/2018	06/12/2023
DOL	DOL	*****3333	MASONRY INDUSTRIES, INC.		442 ARMONK RD MOUNT KISCO NY 10549	06/12/2018	06/12/2023
DOL	DOL		MATTHEW IDEMA GENERAL CONTRACTORS INC		91 COLLEGE AVENUE POUGHKEEPSIE NY 12603	12/04/2015	12/04/2020
DOL	DOL		MATTHEW P. KILGORE		4156 WILSON ROAD EAST TABERG NY 13471	03/26/2019	03/26/2024
DOL	DOL		MAURICE GAWENO		442 ARMONK RD MOUNT KISCO NY 10549	06/12/2018	06/12/2023
DOL	DOL	*****6416	MCCALL MASONRY		P O BOX 304 SAYRE PA 18840	08/09/2016	08/09/2021
DOL	DOL		MCLEAN "MIKKI BEANE"		1229 JAMES STREET SYRACUSE NY 13203	05/02/2017	05/02/2022
DOL	DOL		MCLEAN "MIKKI" DRAKE		1229 JAMES STREET SYRACUSE NY 13203	05/02/2017	05/02/2022
DOL	DOL		MCLEAN M DRAKE-BEANE		1229 JAMES STREET SYRACUSE NY 13203	05/02/2017	05/02/2022
DOL	DOL	*****9445	MCLEAN M WALSH	ELITE PROFESSION AL PAINTING OF CNY	1229 JAMES STREET SYRACUSE NY 13203	05/02/2017	05/02/2022
DOL	DOL	*****9445	MCLEAN M WALSH	ELITE PROFESSION AL PAINTING OF CNY	1229 JAMES STREET SYRACUSE NY 13203	05/02/2017	05/02/2022
DOL	NYC	*****5330	METRO DUCT SYSTEMS INC		1219 ASTORIA BOULEVARD LONG ISLAND CITY NY 11102	04/16/2014	11/19/2020
DOL	DOL	*****3368	MICEK CONSTRUCTION CO INC		20 CROSS STREET FALCONER NY 14733	12/02/2014	12/02/2019
DOL	DOL		MICHAEL A PASCARELLA		SUITE 100 2105 WEST GENESEE STREET SYRACUSE NY 13219	01/06/2016	01/06/2021
DOL	NYC		MICHAEL HIRSCH		C/O MZM CORP 163 S MAIN STREETNEW CITY NY 10956	01/28/2016	01/28/2021
DOL	DOL		MICHAEL LENIHAN		1079 YONKERS AVE UNIT 4YONKERS NY 10704	08/07/2018	08/07/2023
DOL	AG		MICHAEL RIGLIETTI		31 BAY ST BROOKLYN NY 11231	03/28/2018	03/28/2023
DOL	DOL		MICHAEL WILSON	WILSON BROTHER DRYWALL CONTRACTOR S	36 ABERSOLD STREET ROCHESTER NY 14621	08/31/2015	08/31/2020
DOL	NYC		MILANCE HADZIC		22 CALIFORNIA AVE - STE 1 PATERSON NJ 07503	03/11/2015	03/11/2020



**NYS DOL Bureau of Public Work Debarment List 07/22/2019**

**Article 8**

DOL	DOL	****4829	MILESTONE ENVIRONMENTAL CORPORATION		704 GINESI DRIVE SUITE 29MORGANVILLE NJ 07751	04/10/2019	04/10/2024
DOL	AG		MOHAMMED N CHATHA		8831 20TH AVENUE/SUITE 6E BROOKLYN NY 11214	11/17/2015	11/17/2020
DOL	DOL	****2737	MOUNTAIN'S AIR INC		2471 OCEAN AVENUE- STE 7A BROOKLYN NY 11229	09/24/2012	09/18/2020
DOL	AG		MSR ELECTRICAL CONSTRUCTION CORP.		31 BAY ST BROOKLYN NY 11231	03/28/2018	03/28/2023
DOL	DOL		MUHAMMAD BEIG		142 EAST MARKET STREET LONG BEACH NY 11561	03/07/2017	03/07/2022
DOL	DOL		MUHAMMAD BEIG		142 EAST MARKET STREET LONG BEACH NY 11561	03/07/2017	03/07/2022
DOL	DOL		MUHAMMAD PERVAIZ		C/O CHAMPION CONSTRUCTION 2131 SCHENECTADY AVENUEBROOKLYN NY 11234	11/18/2015	11/18/2020
DOL	NYC	****3613	MZM CORP		163 S MAIN STREET NEW CITY NY 10956	01/28/2016	01/28/2021
DOL	DA	****9786	NATIONAL INSULATION & GC CORP		180 MILLER PLACE HICKSVILLE NY 11801	12/12/2018	12/12/2023
DOL	NYC	****1284	NEW AMERICAN RESTORATION INC		22 CALIFORNIA AVE - STE 1 PATERSON NJ 07503	03/11/2015	03/11/2020
DOL	DA	****6988	NEW YORK INSULATION INC		58-48 59TH STREET MASPETH NY 11378	05/16/2012	05/08/2020
DOL	NYC	****4839	NEW YORK RIGGING CORP		58-83 54TH STREET MASPETH NY 11378	02/26/2016	02/26/2021
DOL	NYC	****1968	NORTH AMERICAN IRON WORKS INC		1560 DECATUR STREET RIDGWOOD NY 11385	05/15/2015	05/15/2020
DOL	DOL	****6966	NORTH COUNTRY DRYWALL AND PAINT		23167 COUNTY ROUTE 59 DEXTER NY 13634	10/24/2016	10/24/2021
DOL	DOL	****0065	NORTHEAST LANDSCAPE AND MASONRY ASSOC		3 WEST MAIN ST/SUITE 208 ELMSFORD NY 10523	01/23/2017	01/23/2022
DOL	DOL	****1845	OC ERECTERS, LLC A/K/A OC ERECTERS OF NY INC.		1207 SW 48TH TERRACE DEERFIELD BEACH FL 33442	01/16/2018	01/16/2023
DOL	NYC		ORSON ARROYO		C/O METRO DUCT SYSTEMS 12-19 ASTORIA BOULEVARDLONG ISLAND CITY NY 11102	04/16/2014	11/19/2020
DOL	NYC	****9422	PELIUM CONSTRUCTION, INC.		22-33 35TH ST. ASTORIA NY 11105	12/30/2016	12/30/2021
DOL	DOL		PETER M PERGOLA		3 WEST MAIN ST/SUITE 208 ELMSFORD NY 10523	01/23/2017	01/23/2022
DOL	DOL		PIERRE LAPORT		224 COUNTY HIGHWAY 138 BROADALBIN NY 12025	03/07/2017	03/07/2022
DOL	DOL	****1543	PJ LAPORT FLOORING INC		224 COUNTY HIGHWAY 138 BROADALBIN NY 12025	03/07/2017	03/07/2022
DOL	DOL	****6895	PROLINE CONCRETE OF WNY INC		3090 SHIRLEY ROAD NORTH COLLINS NY 14111	04/19/2011	07/08/2020
DOL	DA	****6817	QUADRANT METAL BUILDINGS LLC		2740 SW MARTIN DOWNS BLVD PALM CITY FL 34990	08/25/2016	08/25/2021
DOL	NYC		RAMESHWAR ASU		137 LIBERTY AVENUE BROOKLYN NY 11212	12/21/2015	12/21/2020
DOL	DOL		RANA A KAHN		1973 81ST ST - SUITE A-5 BROOKLYN NY 11214	01/08/2015	01/08/2020
DOL	NYC		RANTIK PARIKH		13 LORIANN ROAD WARREN NJ 07059	07/15/2015	07/15/2020
DOL	DOL	****2633	RAW POWER ELECTRIC CORP		3 PARK CIRCLE MIDDLETOWN NY 10940	09/16/2013	09/15/2019
DOL	DOL	****2633	RAW POWER ELECTRIC CORP		3 PARK CIRCLE MIDDLETOWN NY 10940	01/30/2018	01/30/2023
DOL	AG	****7015	RCM PAINTING INC.		69-06 GRAND AVENUE 2ND FLOORMASPETH NY 11378	02/07/2018	02/07/2023
DOL	DOL		REGINALD WARREN		161 ROBYN RD MONROE NY 10950	09/15/2014	09/15/2019
DOL	DOL		REGINALD WARREN		161 ROBYN RD MONROE NY 10950	01/30/2018	01/30/2023
DOL	NYC	****3461	RELIANCE GENERAL CONSTRUCTION INC		644 OCEAN PARKWAY BROOKLYN NY 11230	09/02/2015	09/02/2020
DOL	DA		RIANN MULLER		2740 SW MARTIN DOWNS BLVD PALM CITY FL 34990	08/25/2016	08/25/2021
DOL	DOL	****9148	RICH T CONSTRUCTION		107 WILLOW WOOD LANE CAMILLUS NY 13031	11/13/2018	11/13/2023
DOL	DOL		RICHARD MACONE		8617 THIRD AVE BROOKLYN NY 11209	09/17/2018	09/17/2023

**NYSDOL Bureau of Public Work Debarment List 07/22/2019**

**Article 8**

DOL	DOL	*****9148	RICHARD TIMIAN	RICH T CONSTRUCTI ON	108 LAMONT AVE SYRACUSE NY 13209	10/16/2018	10/16/2023
DOL	DOL		RICHARD TIMIAN JR.		108 LAMONT AVE SYRACUSE NY 13209	10/16/2018	10/16/2023
DOL	DOL		RICHARD TIMIAN JR.		108 LAMONT AVE SYRACUSE NY 13209	11/13/2018	11/13/2023
DOL	DOL	*****8618	RIEKS CONTRACTING LLC		4804 GAHWILER ROAD AUBURN NY 13021	05/01/2015	05/01/2020
DOL	DOL		ROBBYE BISSE SAR		89-51 SPRINGFIELD BLVD QUEENS VILLAGE NY 11427	01/11/2003	01/11/3003
DOL	DOL		ROBERT BRUNO		3 GAYLORD ST AUBURN NY 13021	11/15/2016	11/15/2021
DOL	DOL		ROBERT BRUNO		5 MORNINGSIDE DRIVE AUBURN NY 13021	05/28/2019	05/28/2024
DOL	NYC		ROBERT GUIDO		3256 BRUNER AVENUE BRONX NY 10469	07/29/2014	07/29/2019
DOL	DOL		ROBERT TORDELLA		125 CHAUTAUQUA AVENUE LAKEWOOD NY 14750	06/24/2015	06/24/2020
DOL	DOL	*****3859	ROCHESTER ACOUSTICAL CORP		P O BOX 799 HILTON NY 14468	02/19/2016	02/19/2021
DOL	DOL		RODERICK PUGH		404 OAK ST SUITE 101SYRACUSE NY 13203	07/23/2018	07/23/2023
DOL	DOL	*****4880	RODERICK PUGH CONSTRUCTION INC.		404 OAK ST SUITE 101SYRACUSE NY 13203	07/23/2018	07/23/2023
DOL	NYC		RODNEY SCOTT		201 HEMPSTEAD AVENUE WEST HEMPSTEAD NY 11552	10/30/2015	10/30/2020
DOL	DOL		ROMEO WARREN		161 ROBYN RD MONROE NY 10950	09/16/2013	09/15/2019
DOL	DOL		ROMEO WARREN		161 ROBYN RD MONROE NY 10950	01/30/2018	01/30/2023
DOL	DOL		ROSEANNE CANTISANI			06/12/2018	06/12/2023
DOL	DOL		RYAN ALBIE		21 S HOWELLS POINT ROAD BELLPORT NY 11713	02/21/2017	02/21/2022
DOL	DOL	*****3347	RYAN ALBIE CONTRACTING INC		21 S HOWELLS POINT ROAD BELLPORT NY 11713	02/21/2017	02/21/2022
DOL	DOL	*****1365	S & L PAINTING, INC.		11 MOUNTAIN ROAD P.O BOX 408MONROE NY 10950	03/20/2019	03/20/2024
DOL	NYC		SABIR MUHAMMED		SUITE B-8 782 PELHAM PARKWAY SOUTHBRONX NY 10462	04/21/2016	04/21/2021
DOL	NYC		SAEED HASAN		4558 BROADWAY #6 NEW YORK NY 10040	08/04/2014	08/04/2019
DOL	NYC	*****2117	SCOTT ELECTRICAL LLC		201 HEMPSTEAD AVENUE WEST HEMPSTEAD NY 11552	10/30/2015	10/30/2020
DOL	DOL	*****9751	SCW CONSTRUCTION		544 OLD ROUTE 23 ACRE NY 12405	02/14/2017	02/14/2022
DOL	AG		SERGIO RAYMUNDO		109 DUBOIS RD. NEW PALTZ NY 12561	05/20/2016	05/20/2021
DOL	NYC	*****6597	SHAIRA CONSTRUCTION CORP.		421 HUDSON STREET SUITE C5NEW YORK NY 10014	02/20/2019	02/20/2024
DOL	DOL	*****1961	SHANE BURDICK	CENTRAL TRAFFIC CONTROL, LLC.	2238 BAKER ROAD GILLET PA 16923	03/12/2018	03/12/2023
DOL	DOL		SHANE BURDICK		2238 BAKER ROAD GILLET PA 16923	03/12/2018	03/12/2023
DOL	DOL		SHANE NOLAN		9365 WASHINGTON ST LOCKPORT IL 60441	07/23/2018	07/23/2023
DOL	DOL		SHULEM LOWINGER		11 MOUNTAIN ROAD 28 VAN BUREN DRMONROE NY 10950	03/20/2019	03/20/2024
DOL	DOL	*****0816	SOLAR ARRAY SOLUTIONS, LLC		9365 WASHINGTON ST LOCKPORT IL 60441	07/23/2018	07/23/2023
DOL	DOL	*****4025	SOLUTION MATTERS INC		198 NORWOOD ROAD PORT JEFFERSON NY 11776	11/19/2015	11/19/2020
DOL	NYC	*****4934	SPHINX CONTRACTING CORP		240 HOME STREET TEANECK NJ 07666	08/04/2014	08/04/2019
DOL	DOL	*****3496	STAR INTERNATIONAL INC		89-51 SPRINGFIELD BLVD QUEENS VILLAGE NY 11427	08/11/2003	08/11/3003
DOL	DOL	*****9933	STEED GENERAL CONTRACTORS, INC.		1445 COMMERCE AVE BRONX NY 10461	05/30/2019	05/30/2024

**NYSDOL Bureau of Public Work Debarment List 07/22/2019**

**Article 8**

DOL	DOL		STEFANOS PAPASTEFANOU, JR. A/K/A STEVE PAPASTEFANOU, JR.		256 WEST SADDLE RIVER RD UPPER SADDLE RIVER NJ 07458	05/30/2019	05/30/2024
DOL	DOL	*****9751	STEPHEN C WAGAR		544 OLD ROUTE 23 ACRE NY 12405	02/14/2017	02/14/2022
DOL	DOL		STEVE TATE		415 FLAGER AVE #302STUART FL 34994	10/31/2018	10/31/2023
DOL	DOL		STEVEN P SUCATO		15-68 208TH STREET BAYSIDE NY 11360	06/23/2016	06/23/2021
DOL	DOL		STEVEN SAGGESE		3005 WYNSUM AVENUE MERRICK NY 11566	08/18/2014	08/18/2019
DOL	DOL		STEVEN TESTA		50 SALEM STREET - BLDG B LYNNFIELD MA 01940	01/23/2017	01/23/2022
DOL	NYC	*****9432	SUBLINK LTD		346 THIRD AVENUE PELHAM NY 10803	11/19/2015	11/19/2020
DOL	DOL	*****1060	SUNN ENTERPRISES GROUP, LLC		370 W. PLEASANTVIEW AVE SUITE 2.329HACKENSACK NJ 07601	02/11/2019	02/11/2024
DOL	DOL	*****8209	SYRACUSE SCALES, INC.		158 SOLAR ST SYRACUSE NY 13204	01/07/2019	01/07/2024
DOL	DOL	*****7441	T & T CONCRETE INC		2560 HAMBURG TURNPIKE P O BOX 367LACKAWANNA NY 14218	07/08/2015	07/08/2020
DOL	DOL	*****7417	TADCO CONSTRUCTION		101-61 99TH STREET OZONE PARK NY 11416	02/15/2017	02/15/2022
DOL	DOL		TADCO CONSTRUCTION		101-61 99TH STREET OZONE PARK NY 11416	02/15/2017	02/15/2022
DOL	DOL	*****7417	TADCO CONSTRUCTION CORP		101-61 99TH STREET OZONE PARK NY 11416	02/15/2017	02/15/2022
DOL	DOL		TALAILA OCAMPA		1207 SW 48TH TERRACE DEERFIELD BEACH FL 33442	01/16/2018	01/16/2023
DOL	DOL		TAMMY LACITIGNOLA		C/O CATSKILL FENCE INSTAL 5445 ROUTE 32CATSKILL NY 12414	08/22/2014	08/22/2019
DOL	DOL	*****9852	TAP STEEL INC		ROUTE 26 3101 P O BOX 457CONSTABLEVILLE NY 13325	01/28/2016	01/28/2021
DOL	DOL	*****5570	TESTA CORP		50 SALEM STREET - BLDG B LYNNFIELD MA 01940	01/23/2017	01/23/2022
DOL	DOL	*****0887	THE BRINSON PAINTING CORPORATION		72 TAUNTON PLACE BUFFALO NY 14216	04/14/2015	04/14/2020
DOL	DOL	*****5766	THE COKER CORPORATION	COKER CORPORATION	2610 SOUTH SALINA ST SUITE 14SYRACUSE NY 13205	12/04/2018	12/04/2023
DOL	DOL	*****8174	THE DALRYMPLE CORPORATION		UNIT 278 541 10TH STREET NWLANTA GA 30318	12/01/2015	12/01/2020
DOL	DOL	*****8174	THE DALRYMPLE GROUP LLC		289 JONESBORO RD/ STE 216 MCDONOUGH GA 30253	12/01/2015	12/01/2020
DOL	DOL		TIMOTHY A PALUCK		C/O TAP STEEL INC RTE 26 3101/ P O BOX 457CONSTABLEVILLE NY 13325	01/28/2016	01/28/2021
DOL	DOL	*****0600	TOMSON ALLOYS RECYCLING INC		143 FILLMORE AVENUE BUFFALO NY 14210	01/08/2015	01/08/2020
DOL	DOL	*****3453	TORCHIA'S HOME IMPROVEMENT		10153 ROBERTS RD SAUQUOIT NY 13456	08/09/2016	08/09/2021
DOL	DOL	*****6914	TRI-COUNTY RESTORATIONS & CONSTRUCTION INC		13 SUMMERSET DRIVE WALLKILL NY 12589	08/22/2014	08/22/2019
DOL	DOL		TRI-COUNTY RESTORATIONS INC		392 ROCK CUT ROAD WALDEN NY 12586	08/22/2014	08/22/2019
DOL	DOL	*****8311	TRIPLE B FABRICATING, INC.		61 WILLETT ST. PASSAIC NJ 07503	10/26/2016	10/26/2021
DOL	DOL	*****9407	TURBO GROUP INC		15-68 208TH STREET BAYSIDE NY 11360	06/23/2016	06/23/2021
DOL	DOL	*****6392	V.M.K CORP.		8617 THIRD AVE BROOKLYN NY 11209	09/17/2018	09/17/2023
DOL	NYC		VALERIE VISCONTI		346 THIRD AVENUE PELHAM NY 10803	11/19/2015	11/19/2020
DOL	DOL		VICTOR ALICANTI		42-32 235TH ST DOUGLSTON NY 11363	01/14/2019	01/14/2024
DOL	DOL		VICTOR ROTENBERG		C/O GMDV TRANS INC 67048 182ND STREETFRESH MEADOWS NY 11365	06/24/2016	06/24/2021
DOL	NYC		VIKTAR PATONICH		2630 CROPSEY AVE BROOKLYN NY 11214	10/30/2018	10/30/2023
DOL	NYC		VITO GARGANO		1535 RICHMOND AVE STATEN ISLAND NY 10314	12/13/2017	12/13/2022

**NYSDOL Bureau of Public Work Debarment List 07/22/2019**  
**Article 8**

DOL	DOL		WAYNE LIVINGSTON JR	NORTH COUNTRY DRYWALL AND PAINT	23167 COUNTY ROUTE 59 DEXTER NY 13634	10/24/2016	10/24/2021
DOL	DOL		WHITE PLAINS CARPENTRY CORP		442 ARMONK RD	06/12/2018	06/12/2023
DOL	DOL		WILLIAM C WATKINS		1229 JAMES STREET SYRACUSE NY 13203	05/02/2017	05/02/2022
DOL	DOL		WILLIAM DEAK		C/O MADISON AVE CONSTR CO 39 PENNY STREETWEST ISLIP NY 11795	11/02/2016	11/02/2021
DOL	DOL		WILLIE BRINSON		72 TAUNTON PLACE BUFFALO NY 14216	04/14/2015	04/14/2020
DOL	DOL	*****6195	WILSON BROTHER DRYWALL CONTRACTORS		36 ABERSOLD STREET ROCHESTER NY 14621	08/31/2015	08/31/2020
DOL	DOL	*****4043	WINDSHIELD INSTALLATION NETWORK, INC.		200 LATTA BROOK PARK HORSEHEADS NY 14845	03/08/2018	03/08/2023
DOL	DOL	*****4730	XGD SYSTEMS, LLC	TDI GOLF	415 GLAGE AVE #302STUART FL 34994	10/31/2018	10/31/2023
DOL	DOL	*****7345	YES SERVICE AND REPAIRS CORPORATION		145 LODGE AVE HUNTINGTON STATION NY 11476	08/09/2016	08/09/2021
DOL	DOL		YURIY IVANIN		C/O MOUNTAIN'S AIR INC 2471 OCEAN AVENUE-STE 7ABROOKLYN NY 11229	09/24/2012	09/18/2020
DOL	NYC		ZAKIR NASEEM		30 MEADOW ST BROOKLYN NY 11206	10/10/2017	10/10/2022
DOL	NYC	*****8277	ZHN CONTRACTING CORP		30 MEADOW ST BROOKLYN NY 11206	10/10/2017	10/10/2022

**DAVIS-BACON ACT  
FEDERAL PREVAILING WAGE RATES**

"General Decision Number: NY20190008 08/16/2019

Superseded General Decision Number: NY20180008

State: New York

Construction Types: Heavy and Highway

Counties: Cattaraugus, Chautauqua and Erie Counties in New York.

HEAVY CONSTRUCTION PROJECTS: CHAUTAUQUA AND ERIE COUNTIES; AND  
HIGHWAY CONSTRUCTION PROJECTS: CATTARAUGUS, CHAUTAUQUA AND  
ERIE COUNTIES

Note: Under Executive Order (EO) 13658, an hourly minimum wage of \$10.60 for calendar year 2019 applies to all contracts subject to the Davis-Bacon Act for which the contract is awarded (and any solicitation was issued) on or after January 1, 2015. If this contract is covered by the EO, the contractor must pay all workers in any classification listed on this wage determination at least \$10.60 per hour (or the applicable wage rate listed on this wage determination, if it is higher) for all hours spent performing on the contract in calendar year 2019. If this contract is covered by the EO and a classification considered necessary for performance of work on the contract does not appear on this wage determination, the contractor must pay workers in that classification at least the wage rate determined through the conformance process set forth in 29 CFR 5.5(a)(1)(ii) (or the EO minimum wage rate, if it is higher than the conformed wage rate). The EO minimum wage rate will be adjusted annually. Please note that this EO applies to the above-mentioned types of contracts entered into by the federal government that are subject to the Davis-Bacon Act itself, but it does not apply to contracts subject only to the Davis-Bacon Related Acts, including those set forth at 29 CFR 5.1(a)(2)-(60). Additional information on contractor requirements and worker protections under the EO is available at [www.dol.gov/whd/govcontracts](http://www.dol.gov/whd/govcontracts).

Modification Number	Publication Date
0	01/04/2019
1	01/18/2019
2	03/01/2019
3	04/05/2019
4	06/14/2019
5	06/21/2019
6	08/09/2019
7	08/16/2019

ASBE0004-001 05/01/2018

	Rates	Fringes
ASBESTOS WORKER/HEAT & FROST INSULATOR (include application of all materials, protective coverings, coatings, and finishings to all types of mechanical systems).....	\$ 33.25	23.04
HAZARDOUS MATERIAL HANDLER.....	\$ 33.25	23.04

BOIL0007-001 01/01/2017

	Rates	Fringes
BOILERMAKER.....	\$ 33.00	28.15

BRNY0008-004 07/01/2018

CHATAUQUA COUNTY AND CATTARAUGUS COUNTY (EXCLUDING TOWNSHIP OF PERRYSBURG)

	Rates	Fringes
CEMENT MASON/CONCRETE FINISHER...	\$ 30.91	20.62

BRNY0045-001 07/01/2018

ERIE, CATTARAUGUS (Towns of Perrysburg & Gowanda)

	Rates	Fringes
--	-------	---------

Bricklayer, Stonemason.....	\$ 31.32	25.58
Cement mason.....	\$ 31.32	25.58
MARBLE SETTER.....	\$ 31.21	20.54
TERRAZZO FINISHER.....	\$ 29.13	15.12
TILE FINISHER.....	\$ 29.13	15.12
Tilesetter & Terrazzo Worker.....	\$ 31.21	20.54

-----  
 CARP0276-002 07/01/2019

CHAUTAUQUA; CATTARAUGUS (Remainder of County).

	Rates	Fringes
Carpenters:.....	\$ 31.23	22.75+a

FOOTNOTES:

a. Paid Holidays: Independence Day and Labor Day, provided the employee works his scheduled day before and after the holiday and is on the payroll week in which the holiday falls.

-----  
 CARP0276-013 07/01/2019

CATTARAUGUS (Townships of Persia and Perrysburg) ERIE (Grand Island)

	Rates	Fringes
CARPENTER		
Heavy & Highway.....	\$ 34.60	28.76

FOOTNOTES:

a. PAID HOLIDAYS: Independence Day, Labor Day, provided the employee works his scheduled day before and after the holiday and is on the payroll in the payroll week in which the holiday falls.

-----  
 CARP0276-021 07/01/2019



CATTARAUGUS (Townships of Persia and Perrysburg)

	Rates	Fringes
CARPENTER		
Heavy & Highway.....	\$ 31.23	22.75

FOOTNOTES:

- a. PAID HOLIDAYS: Independence Day, Labor Day, provided the employee works his scheduled day before and after the holiday and is on the payroll in the payroll week in which the holiday falls.

-----  
 ELEC0041-007 05/27/2019

ERIE, CATTARAUGUS (Ashford, East Otto, Ellicottville, Farmersville, Freedom, Franklinville, Lyndon, Machias, Mansfield, New Albion, Otto, Perrysburg, Persia and Yorkshire Townships)

	Rates	Fringes
CABLE SPLICER.....	\$ 36.73	3%+22.29
ELECTRICIAN.....	\$ 35.64	29.16

-----  
 ELEC0041-008 05/27/2019

ERIE, CATTARAUGUS (Ashford, East Otto, Ellicottville, Farmersville, Freedom, Franklinville, Lyndon, Machias, Mansfield, New Albion, Otto, Perrysburg, Persia and Yorkshire Townships)

	Rates	Fringes
Communications System		
CABLER.....	\$ 11.10	11.97+a
INSTALLER.....	\$ 18.35	18.44+a
MASTER TECHNICIAN.....	\$ 28.05	18.73+a
SOUND WIREMAN.....	\$ 25.50	18.66+a

Work covers low voltage construction, installation,

maintenance, and removal of teledata facilities (voice, data and video) including outside plant, telephone and data inside wire, interconnect, terminal equipment, central offices, PABX fiber optic cable and equipment, railroad communications, micro waves, V-Sat, bypass, CATV, WAN (wide area networks); LAN (local area networks) and ISDN (integrated systems digital network). Also, installation of sound systems, nurses call systems, intercom systems, staff registry/locating/signaling systems, antenna systems and associated devices; installation of security systems and apparatus, and cabling from VDT's to computers. This work does not apply to new construction, or to the installation of raceway systems and boxes for the above work.

FOOTNOTE:

- a. Paid Holidays: New Year's Day, Memorial Day, Independence Day, Labor Day, Thanksgiving Day, the day after Thanksgiving Day, Christmas Day.

-----  
 ELEC0106-002 01/01/2019

CHAUTAUQUA, CATTARAUGUS (Remainder of County)

	Rates	Fringes
CABLE SPLICER.....	\$ 35.75	20.68
ELECTRICIAN.....	\$ 36.51	23.4353

-----  
 ELEC1249-003 05/06/2019

	Rates	Fringes
ELECTRICIAN (LINE CONSTRUCTION: LIGHTING AND TRAFFIC SIGNAL Including any and all Fiber Optic Cable necessary for Traffic Signal Systems, Traffic Monitoring systems and Road Weather information systems)		
Flagman.....	\$ 27.00	6.75%+24.15
Groundman (Truck Driver)....	\$ 36.00	6.75%+24.15

Groundman Truck Driver (tractor trailer unit).....	\$ 36.00	6.75%+24.15
Lineman & Technician.....	\$ 45.00	6.75%+24.15
Mechanic.....	\$ 36.00	6.75%+24.15

FOOTNOTE:

a. New Year's Day, Memorial Day, Independence Day, Labor Day, Thanksgiving Day, Christmas Day, plus President's Day, Good Friday, Decoration Day, Election Day for the President of the United States and Election Day for the Governor of the State of New York, provided the employee works the day before or the day after the holiday.

-----  
ELEC1249-004 05/06/2019

	Rates	Fringes
ELECTRICIAN (Line Construction)		
Overhead and underground distribution and maintenance work and all overhead and underground transmission line work including any and all fiber optic ground wire, fiber optic shield wire or any other like product by any other name manufactured for the dual purpose of ground fault protection and fiber optic capabilities :		
Flagman.....	\$ 31.23	6.75%+24.15
Groundman digging machine operator.....	\$ 46.85	6.75%+24.15
Groundman truck driver (tractor trailer unit).....	\$ 41.64	6.75%+24.15
Groundman Truck driver.....	\$ 41.64	6.75%+24.15
Lineman and Technician.....	\$ 52.05	6.75%+24.15
Mechanic.....	\$ 41.64	6.75%+24.15
Substation:		
Cable Splicer.....	\$ 57.26	6.75%+24.15

Flagman.....	\$ 31.23	6.75%+24.15
Ground man truck driver....	\$ 41.64	6.75%+24.15
Groundman digging machine operator.....	\$ 46.85	6.75%+24.15
Groundman truck driver (tractor trailer unit)....	\$ 41.64	6.75%+24.15
Lineman & Technician.....	\$ 52.05	6.75%+24.15
Mechanic.....	\$ 41.64	6.75%+24.15
Switching structures; railroad catenary installation and maintenance, third rail type underground fluid or gas filled transmission conduit and cable installations (including any and all fiber optic ground product by any other name manufactured for the dual purpose of ground fault protection and fiber optic capabilities), pipetype cable installation and maintenance jobs or projects, and maintenance bonding of rails; Pipetype cable installation		
Cable Splicer.....	\$ 58.71	6.75%+24.15
Flagman.....	\$ 32.02	6.75%+24.15
Groundman Digging Machine Operator.....	\$ 48.03	6.75%+24.15
Groundman Truck Driver (tractor-trailer unit)....	\$ 42.70	6.75%+24.15
Groundman Truck Driver....	\$ 42.70	6.75%+24.15
Lineman & Technician.....	\$ 53.37	6.75%+24.15
Mechanic.....	\$ 42.70	6.75%+24.15

FOOTNOTE:

a. PAID HOLIDAYS: New Year's Day, Presidents' Day, Memorial Day, Good Friday, Independence Day, Labor Day, Thanksgiving Day, Christmas Day, and Election Day for the President of the United States and Election Day for the Governor of New York State, provided the employee works two days before or

two days after the holiday.

-----  
ELEC1249-008 01/01/2019

	Rates	Fringes
ELECTRICIAN (Line Construction)		
TELEPHONE, CATV FIBEROPTICS CABLE AND EQUIPMENT		
Cable splicer.....	\$ 32.78	3%+4.93
Groundman.....	\$ 16.49	3%+4.93
Installer Repairman- Teledata Lineman/Technician- Equipment Operator.....	\$ 31.12	3%+4.93
Tree Trimmer.....	\$ 25.79	3%+9.98+a

a. New Year's Day, President's Day, Good Friday, Decoration  
Day, Independence Day, Labor Day, Veteran's Day,  
Thanksgiving Day, Day after Thanksgiving, Christmas Day.

-----  
ELEV0014-001 01/01/2019

	Rates	Fringes
ELEVATOR MECHANIC.....	\$ 49.81	33.705+a+b

FOOTNOTE:

- a. Vacation: 6%/under 5 years based on regular hourly rate for all hours worked. 8%/over 5 years based on regular hourly rate for all hours worked.
- b. PAID HOLIDAYS: New Year's Day; Memorial Day; Independence Day; Labor Day; Veterans' Day; Thanksgiving Day; the Friday after Thanksgiving Day; and Christmas Day.

-----  
ENGI0017-012 07/01/2018

	Rates	Fringes
--	-------	---------

Power equipment operators:

GROUP 1.....	\$ 38.73	29.84+a
GROUP 2.....	\$ 34.23	29.84+a
GROUP 3.....	\$ 39.48	29.84+a
GROUP 4.....	\$ 39.73	29.84+a
GROUP 5.....	\$ 40.23	29.84+a
GROUP 6.....	\$ 39.80	29.84+a

NOTE: HAZARDOUS WASTE PREMIUM       \$2.50  
TUNNEL WORK                               \$1.00

FOOTNOTES:

a. PAID HOLIDAYS: A-New Year's Day; B-Memorial Day;  
C-Independence Day; D-Labor Day; Thanksgiving Day;  
F-Christmas Day, provided the employee has worked the day  
before and the day after the holiday.

POWER EQUIPMENT OPERATORS CLASSIFICATIONS

GROUP 1: Air hoist, all boom type equipment (100 ft. or less), all pan and carry-alls, archer hoist, asphalt roller asphalt spreader or paver, automatic fine grade machine (CMI and similar type), archer hoist, backhoe and pull hoe (tractor mounted and rubber mounted), back filling machine, belt place (CMI and similar), bending machine (pipe), bituminous spreader and mixer, black top plant (automated), black top plant (non-automated), blast or rotary drill (truck or track mounted), blower for burning brush, boiler (when used for power), boom trucks, boring machine, bulldozer, cableway cage hoist, caisson auger, central mix plant (and all concrete batching plants), cherry picker (over 5 tons), cherry picker (under 5 tons), chipping machine and chip spreader, concrete curb and gutter machines, concrete curing machine, concrete mixer (over 1/2 cu. yd.) concrete pavement spreaders and finishers, concrete paver, concrete pump, concrete saw (self-propelled), conveyor, core drill, crane, crusher, derrick operator, dragline, dredge, drill rig (tractor mounted), dual drum paver, electric pump used in conjunction with well point systems, elevating grader self-propelled or towed), elevator excavator (all purpose, hydraulically operated) farm tractor with accessories, fine grade machine, forklift, front end loader, generator (10 outlets or more), gradall, grader, grout or gunite machine, head tower, hoist-one drum, hoisting engine, hydraulic

boom, hydraulic hammer, (self propelled), hydraulic pipe jack machine (or similar type machine), hydraulic system pumps, hydro crane, hydro hammer (or similar type), industrial tractor, jersey spreader, kolman plant loader (and similar type loaders), locomotive, lubrication truck, maintenance engineer, maintenance lubrication unit or truck, mine hoist, mixer for stabilized base (self-propelled), monorail, motorized hydraulic pin puller, motorized hydraulic seeder mucking machine, mulching machine, multiple drum hoist (more than 1 drum in use), overhead crane, peine crane (or similar type), pile driver, plant engineer, pneumatic mixer, post hole digger, power boom, pumpcrete, push or snatch cat, quarry master or equivalent road widener, rock bit sharpener (all types), roller (all), rolling machine (pipe), rotomill, scoopmobile, shovel, side boom, skimmer, slip form paver (CMI and similar type, first and second operator), snorkel, strato-tower, stump chipping machine, tire truck and repair, towed roller, tractor drawn belt type grader/loader, tractor shovel, tractor with towed accessories, tractors (when using winch power), tractors, trencher, truck crane, tunnel shovel, tube finisher (CMI and similar type), vibratory compactor, vibro tamp, well drilling machine, well point, winch, winch truck with "A" frame.

GROUP 2: Aggregate bin, CMI and similar type concrete spreads, cement bin, chipping machine and chip spreader, compressors (4 or less), compressors: (any size, but subject to other provisions for compressors, dust collectors, generators, mechanical heaters, pumps, welding machines (four of any type or combination), concrete mixer (1/2 cu. yd. and under), fireman, form tamper, fuel truck, heating boiler (used for temporary heat), jeep trencher, power heaterman, power plant in excess of 10 K.W., pump (4" or over), revinuis widener, stem cleaner, stump chipping machine, welding machine (1 machine over 300 amps or 2 or 3 machines regardless of amps).

GROUP 3: Crane with boom over 100 feet

GROUP 4: Crane with boom over 200 feet

GROUP 5: Crane with boom over 300 feet

GROUP 6: Master mechanic

-----  
 IRON0006-003 07/01/2018

ERIE COUNTY (Excluding Grand Island Township), CATTARAUGUS AND  
 CHAUTAUQUA

	Rates	Fringes
Ironworker		
Fence Erectors.....	\$ 29.15	25.32
Structural, Ornamental, Reinforcing Steel, Welders, Riggers and Rodman.	\$ 30.58	26.82
Window Erectors.....	\$ 28.23	26.82

-----  
 IRON0006-015 07/01/2018

ERIE (Township of Grand Island)

	Rates	Fringes
IRONWORKER		
Ironworker.....	\$ 30.58	26.82
Sheeter.....	\$ 30.58	26.82

-----  
 LABO0210-003 07/01/2017

	Rates	Fringes
LABORER		
ERIE COUNTY HEAVY & HIGHWAY		
GROUP 1.....	\$ 29.61	24.35
GROUP 2.....	\$ 29.81	24.35
GROUP 3.....	\$ 30.01	24.35
GROUP 4.....	\$ 30.21	24.35
ERIE COUNTY SEWER/WATER		
GROUP 1.....	\$ 29.61	24.35
GROUP 2.....	\$ 29.71	24.35
GROUP 3.....	\$ 29.76	24.35
GROUP 4.....	\$ 29.86	24.35
GROUP 5.....	\$ 30.21	24.35
GROUP 6.....	\$ 30.61	24.35



ERIE COUNTY TUNNEL

GROUP 1.....	\$ 31.11	24.35
GROUP 2.....	\$ 31.26	24.35
GROUP 3.....	\$ 31.36	24.35
GROUP 4.....	\$ 31.86	24.35
GROUP 5.....	\$ 31.96	24.35
GROUP 6.....	\$ 32.36	24.35
GROUP 7.....	\$ 32.61	24.35

HEAVY & HIGHWAY CLASSIFICATIONS

GROUP 1: Laborers; flagmen; outboard and hand boats; demolition worker; IBC barriers (except on structures); guard rails; road markers

GROUP 2: Bull float; chain saw; concrete aggregate bin; concrete bootman; gin buggy; hand or machine vibrator; jackhammer; mason tender mortar mixer; pavement breaker; handlers of all steel mesh; small generators for laborers' tools; installation of bridge drainage pipe; pipelayers; vibrator type rollers; tamper; drill doctor; tail or screw operator on asphalt paver; water pump (2" and single diaphragm); nozzle (asphalt, gunnite, seeding and sandblasting); laborers on chain link fence erection; rock splitter and power unit; pusher type concrete saw and all other gas, electric, oil and air tool operators; wrecking laborers; laser man

GROUP 3: All rock or drilling machine operators (except quarry master and similar type); acetylene torch operator; asphalt raker; powderman; welder

GROUP 4: Blasters; curb & flat work form setters (except on structures); stone or granite curb setters

SEWER/WATER CLASSIFICATIONS

GROUP 1: General; flagman; top man; wreckers

GROUP 2: Foundation; rod carriers; plaster tender; scaffold bootman; pneumatic, gas, electric tool operator; jackhammer; chipping guns

GROUP 3: Mortar mixer over 8 feet in depth

GROUP 4: Pavement formsetter; steelburner; caisson; wagon  
drill operator; pipelayer; swing scaffold

GROUP 5: Utility pave driver; laser operator

GROUP 6: Blaster

TUNNEL CLASSIFICATIONS

GROUP 1: Mole nipper; powder handler; top laborer

GROUP 2: Air spade; jackhammer; pavement breaker

GROUP 3: Top bell

GROUP 4: Bottom bell; side or roofbelt driller; burners;  
trackmen; nippers; derailmen; hosemen; groutmen; gravelmen;  
form workers; movers & shaftmen; conveyormen

GROUP 5: Powder monkey

GROUP 6: Blasters; ironmen; welder; heading driller

GROUP 7: Piledriver; rigger

FOR HEAVY/HIGHWAY & TUNNEL: Additional \$1.00 added to base  
rate for all deleader & asbestos work. Additional \$2.00  
added to base rate for all hazardous waste work.

-----  
LAB00621-001 07/01/2019

CATTARAUGUS COUNTY and Twnships of French Creek, Clymer,  
Harmony, Busti, Kiantone, Carroll, Mina, Sherman, Ellicott,  
Poland, Jamestown, North Harmony, Gerry, Chautauqua, Ellington,  
Ellery, and Stockton in CHAUTAUQUA COUNTY

Rates Fringes

Laborers:

HEAVY AND HIGHWAY

(ZONE I)

GROUP 1.....	\$ 27.84	21.85
GROUP 2.....	\$ 28.24	21.85

LABORER CLASSIFICATIONS (HEAVY & HIGHWAY)

GROUP 1: Flagman; outboard and hand boats; Bull float; Chain Saw; Concrete aggregate bin; Concrete boot; Gin Buggy; Hand or machine vibrator jack hammer; Mason tender; Mortar mixer; pavement breaker; Handler of all stee mesh; Small generator for laborer tools, installation of bridge drainage pipe; Pipe layers; Vibrator type rollers; Tamper drill doctor; Water pump operator (1-1/2" and singe diaphragm); Nozzle (asphalt, gunite, seeding and sandblasting); Laborers on chain link fence erection; rock splitter and power unit; Pusher type concrete saw and all other gas, electric, oil and air tool operators; wrecking laborers.

GROUP 2: Blasters; Form setter; stone or granite curb setters; Designated asphalt rakers (not to include cold patch); tail or screw operator on asphalt paver. All rock or drilling machine operators (except quarry master and similar type); acetylene torch operators; powdermen.

-----  
LAB00621-002 07/01/2019

CHAUTAUQUA COUNTY (Townships of Ripley, Westfield, Portland, Pomfret, Dunkirk, Sheridan, Hanover, Villenova, Arkwright, Cherry Creek and Charlotte)

Rates Fringes

Laborers:

CATTARAUGUS COUNTY AND  
CHAUTAUQUA COUNTY  
(Remaining Townships)

HEAVY AND HIGHWAY

GROUP 1.....	\$ 27.84	21.85
GROUP 2.....	\$ 28.24	21.85

CHAUTAUQUA COUNTY

(Townships of Ripley,

Westfield, Portland,  
 Pomfret, Dunkirk,  
 Sheridan, Hanover,  
 Villenova, Arkwright,  
 Cherry Creek and  
 Charlotte) HEAVY AND  
 HIGHWAY CONSTRUCTION

GROUP 1.....	\$ 28.79	21.85
GROUP 2.....	\$ 29.19	21.85

For HEAVY & HIGHWAY CLASSIFICATIONS

GROUP 1: Flagmen, Outboard and Hand Boats, Demolition Worker, Nurseryman, IBC Barriers except on Structures, Guard Rail and Road Markers, Bull Float, Chain Saw, Concrete Aggregate Bin, Concrete Bootman, Gin Buggy, Hand or Machine Vibrator, Jack Hammer, Mason Tender, Mortar Mixer, Pavement Breaker, Handlers of All Steel Mesh, Small Generators for Laborers' tools, Installation of Bridge Drainage Pipe, Pipe Layers, Vibrator Type Rollers, Tamper, Drill Doctor, Tail or Screw Opertor on Asphalt Paver, Waterpump Operators (1 1/2" and single diaphragm), Nozzle (asphalt gunite, seeding and sand blasting), Laborers on Chain Link Fence Erection, Rock Splitter and Power Unit, Pusher Type Concrete Saw and all other gas, electric, oil and air tool operators, Wrecking Laborer, Laser Man.

GROUP 2: All Rock or Drilling Machine Operators (except quarry master and similar type), Acetylene Torch Operators and Asphalt Raker, Powderman, Blaster, Curb and Flat Work Form Setter not on structures, Stone or Granite curb setters, Stone Cutter.

For HEAVY & HIGHWAY CLASSIFICATIONS in CHAUTAQUA COUNTY  
 (Remaining Townships)

GROUP 1: Flagman, Outboard and hand boats, Bull float, Chain Saw, Concrete aggregate bin, Concrete boot, Gin buggy, Hand or machine vibrator jack hammer, Mason tender, Mortar mixer, pavement breaker, handler of all steel mesh, Small generator for laborers' tools, installation of bridge drainage pipe; Pipe layers, Vibrator type rollers, Tamper drill doctor, Water pump operator (1 1/2" and single diaphragm), Nozzle (asphalt, gunite, seeding and

sandblasting) Laborers on chain link fence erection, rock splitter and power unit, Pusher type concrete saw and all other gas, electric, oil and air tool operators, wrecking laborers.

GROUP 2: Blasters, Form setters, stone or granite curb setters; Designated asphalt rakers (not to include cold patch), tail or screw operator on asphalt paver. All rock or drilling machine operators (except quarry master and similar type), acetylene torch operators, powderman.

-----  
 PAIN004-001 05/01/2019

CHAUTAUQUA COUNTY (Townships of Awkwright, Dunkirk, Hanover, Pomfret, Portland, Sheridan, Villenova); CATTARAUGUS COUNTY (Townships of Ashford, Dayton, East Otto, Machias, Otto, Perrysburg, Persia, Yorkshire); ERIE COUNTY (Entire county, excluding area North of Whitehaven Road, Grand Island)

	Rates	Fringes
Painters: (BUILDING CONSTRUCTION)		
ERIE COUNTY		
BRUSH AND ROLLER.....	\$ 26.45	24.94
DRYWALL/TAPING.....	\$ 26.95	24.94
WALLCOVERING.....	\$ 26.45	24.94
Painters: (HEAVY & HIGHWAY CONSTRUCTION)		
CATTARAUGUS, CHAUTAUQUA & ERIE COUNTIES.....		
	\$ 38.50	28.40

-----  
 PAIN004-004 05/01/2019

ERIE COUNTY, (AREA NORTH OF WHITEHAVEN ROAD, GRAND ISLAND, NEW YORK)

	Rates	Fringes
Painters:		
BUILDING CONSTRUCTION		
Lead Abatement.....	\$ 25.43	19.51

Painters.....	\$ 24.68	19.51
Spraying, Paperhangers, Sand-Blasting, Swinging scaffold.....	\$ 24.93	19.51
Tapers.....	\$ 25.18	19.51
HEAVY & HIGHWAY CONSTRUCTION		
Bridge Painter.....	\$ 38.50	28.40

-----  
PAIN0004-007 05/01/2019

	Rates	Fringes
GLAZIER.....	\$ 27.12	22.25

-----  
PAIN0004-008 05/01/2019

CATTARAUGUS COUNTY - Townships of Leon, Conewango, Randolph,  
South Valley, Napoli and New Albion;

CHAUTAUQUA COUNTY - Townships of French Creek, Mina, Ripley,  
Westfield, Sherman, Clymer, Chautauqua, North Harmony, Harmony,  
Busti, Ellery, Stockton, Charlotte, Gerry, Ellicott, Jamestown,  
Kiantone, Carroll, Poland, Ellington and Cherry Creek.

	Rates	Fringes
Painters: (HEAVY & HIGHWAY CONSTRUCTION)		
Bridges.....	\$ 38.50	28.40

-----  
PAIN0004-017 05/01/2019

CATTARAUGUS COUNTY (Townships of Cold Spring, Elko, Mansfield,  
Little Valley, Salamanca Indian Reservation, Red House,  
Ellicottville, Great Valley, Carrolton, Franklinville,  
Humphrey, Allegany, Freedom, Farmersville, Lyndon, Ishua,  
Hinsdale, Olean and Portville)

	Rates	Fringes
Painters: (HEAVY & HIGHWAY CONSTRUCTION)		

Bridges.....\$ 38.50                   28.40

-----  
PLAS0009-001 04/01/2019

                                  Rates                   Fringes

PLASTERER.....\$ 30.15                   20.49

-----  
PLAS0111-001 07/01/2018

                                  Rates                   Fringes

CEMENT FINISHER.....\$ 30.00                   30.62

-----  
PLUM0022-001 04/29/2019

CATTARAUGUS- Townships of Perryburg, Dayton, Persia, Otto,  
Leon, and New Albion;

CHATAUQUA- Townships of Hanover, Sheridan, Dunkirk, Pomfret,  
Arkwright, Villanova, Portland, Stockton, Charlotte, Ripley and  
Westfield;

ERIE- All Townships in the County.

                                  Rates                   Fringes

PLUMBER/PIPEFITTER

    ZONE 1.....\$ 36.45                   25.75

Steamfitter

    ZONE 1.....\$ 36.45                   25.75

-----  
PLUM0022-004 04/29/2019

ZONE 2

CATTARAUGUS- Townships of Conewango, Napoli, East Otto,  
Mansfield, Little Valley, Randolph, South Valley, Colesprings,  
Salemanna, Ashford, Ellicottville, Great Valley, Carrollton,  
Yorkshire, Freedom, Farmersville Station, Machias, Lyndon,  
Franklinville, Humphrey, Ischua, Allegany, Hinsdale, Olean,  
Portville;

ZONE 1

CHAUTAUQUA - Townships of Cherry Creek, Ellington, Polland,

Carroll, Gerry, Ellicott, Kiantone, Ellery, Busti, Harmony,  
 North Harmony, Chautauqua, Sherman, Mina, French Creek, Clymer.

	Rates	Fringes
PLUMBER/PIPEFITTER		
ZONE 1.....	\$ 36.45	25.75
ZONE 2.....	\$ 34.88	25.75

-----  
 ROOF0074-001 06/01/2019

ERIE COUNTY

	Rates	Fringes
Roofers:		
Composition.....	\$ 29.00	22.39
Slate & Tile.....	\$ 29.15	22.39

-----  
 ROOF0210-005 06/01/2010

	Rates	Fringes
ROOFER.....	\$ 23.65	11.99

-----  
 \* SFNY0669-001 04/01/2019

	Rates	Fringes
SPRINKLER FITTER.....	\$ 34.91	24.93

-----  
 SHEE0071-001 05/28/2018

ERIE COUNTY:

	Rates	Fringes
Sheet metal worker.....	\$ 34.38	24.39

-----  
 SHEE0112-001 07/01/2016

CATTARAUGUS AND CHAUTAUQUA COUNTIES:

Rates	Fringes
-------	---------



SHEET METAL WORKER.....\$ 26.48                    22.22

-----  
TEAM0264-001 04/01/2019

CATTARAUGUS AND CHAUTAUQUA COUNTIES

	Rates	Fringes
Truck drivers:		
GROUP 1.....	\$ 38.31	14.78+a
GROUP 2.....	\$ 38.31	14.78+a

FOOTNOTE:

a. PAID HOLIDAYS: Memorial Day, Independence Day, Labor Day, Thanksgiving Day and Christmas Day, provided employee has worked the day before and the day after the holiday.

TRUCK DRIVER CLASSIFICATIONS

GROUP 1: Pickups, panel trucks, flatboy material trucks (straight jobs), single-axle dump trucks, dumpsters, Tandems, batch trucks, mechanics semi trailers, low-boy trucks, asphalt distributor trucks, agitator, mixer trucks and dumpcrete type vehicles, truck mechanics, fuel trucks.

GROUP 2: Specialized earth moving equipment-euclid type or similar off-highway equipment, where not self-loaded, straddle (ross) carrier, self-contained concrete unit, off-highway tandem back-dump, twin engine equipent and double-hitched equipment where not self-loaded.

-----  
TEAM0449-002 07/01/2018

ERIE COUNTY

	Rates	Fringes
Truck drivers: (Includes Single Axle Dump and Off-Highway Dump Trucks).....	\$ 38.15	5.00+a+b

Work on a hazardous waste site then additional \$2.00 per hour.

FOOTNOTE: a. Pension \$56.20 per day

b. Paid Holidays: New Years Day, Memorial Day, Independence Day, Labor Day, Thanksgiving Day, Christmas Day provided the employee has worked the working day before and after the holiday

-----  
TEAM0449-005 06/01/2018

ERIE COUNTY

	Rates	Fringes
Truck drivers: (Dump Truck Only, Excludes Single Axle Dump and Off-Highway Dump Trucks).....	\$ 21.25	3.46+a

FOOTNOTE: a. Paid Holidays: New Years Day, Memorial Day, Independence Day, Labor Day, Thanksgiving Day, Christmas Day provided the employee has worked the working day before and after the holiday

-----  
WELDERS - Receive rate prescribed for craft performing operation to which welding is incidental.

=====

Note: Executive Order (EO) 13706, Establishing Paid Sick Leave for Federal Contractors applies to all contracts subject to the Davis-Bacon Act for which the contract is awarded (and any solicitation was issued) on or after January 1, 2017. If this contract is covered by the EO, the contractor must provide employees with 1 hour of paid sick leave for every 30 hours they work, up to 56 hours of paid sick leave each year. Employees must be permitted to use paid sick leave for their own illness, injury or other health-related needs, including preventive care; to assist a family member (or person who is like family to the employee) who is ill, injured, or has other health-related needs, including preventive care; or for reasons resulting from, or to assist a family member (or person who is

like family to the employee) who is a victim of, domestic violence, sexual assault, or stalking. Additional information on contractor requirements and worker protections under the EO is available at [www.dol.gov/whd/govcontracts](http://www.dol.gov/whd/govcontracts).

Unlisted classifications needed for work not included within the scope of the classifications listed may be added after award only as provided in the labor standards contract clauses (29CFR 5.5 (a) (1) (ii)).

-----

The body of each wage determination lists the classification and wage rates that have been found to be prevailing for the cited type(s) of construction in the area covered by the wage determination. The classifications are listed in alphabetical order of ""identifiers"" that indicate whether the particular rate is a union rate (current union negotiated rate for local), a survey rate (weighted average rate) or a union average rate (weighted union average rate).

#### Union Rate Identifiers

A four letter classification abbreviation identifier enclosed in dotted lines beginning with characters other than ""SU"" or ""UAVG"" denotes that the union classification and rate were prevailing for that classification in the survey. Example: PLUM0198-005 07/01/2014. PLUM is an abbreviation identifier of the union which prevailed in the survey for this classification, which in this example would be Plumbers. 0198 indicates the local union number or district council number where applicable, i.e., Plumbers Local 0198. The next number, 005 in the example, is an internal number used in processing the wage determination. 07/01/2014 is the effective date of the most current negotiated rate, which in this example is July 1, 2014.

Union prevailing wage rates are updated to reflect all rate changes in the collective bargaining agreement (CBA) governing this classification and rate.

#### Survey Rate Identifiers

Classifications listed under the "SU" identifier indicate that no one rate prevailed for this classification in the survey and the published rate is derived by computing a weighted average rate based on all the rates reported in the survey for that classification. As this weighted average rate includes all rates reported in the survey, it may include both union and non-union rates. Example: SULA2012-007 5/13/2014. SU indicates the rates are survey rates based on a weighted average calculation of rates and are not majority rates. LA indicates the State of Louisiana. 2012 is the year of survey on which these classifications and rates are based. The next number, 007 in the example, is an internal number used in producing the wage determination. 5/13/2014 indicates the survey completion date for the classifications and rates under that identifier.

Survey wage rates are not updated and remain in effect until a new survey is conducted.

#### Union Average Rate Identifiers

Classification(s) listed under the UAVG identifier indicate that no single majority rate prevailed for those classifications; however, 100% of the data reported for the classifications was union data. EXAMPLE: UAVG-OH-0010 08/29/2014. UAVG indicates that the rate is a weighted union average rate. OH indicates the state. The next number, 0010 in the example, is an internal number used in producing the wage determination. 08/29/2014 indicates the survey completion date for the classifications and rates under that identifier.

A UAVG rate will be updated once a year, usually in January of each year, to reflect a weighted average of the current negotiated/CBA rate of the union locals from which the rate is based.

---

#### WAGE DETERMINATION APPEALS PROCESS

1.) Has there been an initial decision in the matter? This can be:

\* an existing published wage determination

- \* a survey underlying a wage determination
- \* a Wage and Hour Division letter setting forth a position on a wage determination matter
- \* a conformance (additional classification and rate) ruling

On survey related matters, initial contact, including requests for summaries of surveys, should be with the Wage and Hour Regional Office for the area in which the survey was conducted because those Regional Offices have responsibility for the Davis-Bacon survey program. If the response from this initial contact is not satisfactory, then the process described in 2.) and 3.) should be followed.

With regard to any other matter not yet ripe for the formal process described here, initial contact should be with the Branch of Construction Wage Determinations. Write to:

Branch of Construction Wage Determinations  
Wage and Hour Division  
U.S. Department of Labor  
200 Constitution Avenue, N.W.  
Washington, DC 20210

2.) If the answer to the question in 1.) is yes, then an interested party (those affected by the action) can request review and reconsideration from the Wage and Hour Administrator (See 29 CFR Part 1.8 and 29 CFR Part 7). Write to:

Wage and Hour Administrator  
U.S. Department of Labor  
200 Constitution Avenue, N.W.  
Washington, DC 20210

The request should be accompanied by a full statement of the interested party's position and by any information (wage payment data, project description, area practice material, etc.) that the requestor considers relevant to the issue.

3.) If the decision of the Administrator is not favorable, an interested party may appeal directly to the Administrative Review Board (formerly the Wage Appeals Board). Write to:

Administrative Review Board  
U.S. Department of Labor  
200 Constitution Avenue, N.W.

Washington, DC 20210

4.) All decisions by the Administrative Review Board are final.

=====

END OF GENERAL DECISION"



**This Page Left Intentionally Blank**



## AGREEMENT

---

This AGREEMENT made as of the \_\_\_\_\_ day of \_\_\_\_\_ in the year 20\_\_ by and between the County of Cattaraugus, a municipal corporation hereinafter called the “County” and \_\_\_\_\_ hereinafter called the “Contractor”.

WITNESSETH that the County and Contractor in consideration of the mutual covenants hereinafter set forth, agree as follows:

Article 1. WORK. The Contractor will perform all Work as shown in the Contract Documents for the completion of the Project generally described as the Replacement of New Albion Bridge #35 (B.I.N. 3322810) Tannery Street over Tributary South Branch Cattaraugus Creek.

(a) The Contractor shall furnish all of the materials and do all the Work required for the Replacement of New Albion Bridge #35 (B.I.N. 3322810) Tannery Street over Tributary South Branch Cattaraugus Creek and all other incidental work detailed in the contract documents.

Article 2. ENGINEER. The Project has been designed by Stantec Consulting Services Inc. A Construction Inspection firm selected by the county will provide construction oversight and is hereinafter called the ENGINEER. The County and the ENGINEER will provide all on-site observation services, and County observation personnel will also be referred to as the ENGINEER.

Article 3. CONTRACT TIME. Time of beginning rate of progress and time of completion are essential conditions of the Contract. The Contractor shall commence work within ten (10) days of the effective date of the Contract unless written consent is given by the County to begin at a later date. No field in-stream work shall commence before May 1, 2020 without prior written approval by the County. All in-stream work shall be completed within 100 days of the commencement of the in-stream work. All work shall be completed within 160 days from the commencement of the in-stream work but no later than October 31, 2020.

Article 4. CONTRACT PRICE. The County shall pay the Contractor for the performance of the Work in accordance with the Itemized Bid indicated in the bid documents.

Article 5. PAYMENTS. The County shall make payments on the account of the Contract as follows:

- (a) Upon request from the Contractor, the Engineer and the County will review and approve statements prepared by the Contractor for the total quantity of work properly completed by the Contract as of a specified date noted on the statement. No such statement, however, will be reviewed by the Engineer and County within one month after the start of Work under contract, or at intervals of less than one month. The County will pay the Contractor of the amount of each statement, less prior payments, forty-five (45) days after approval of the statement. Neither statement nor payment shall mean that any Work is accepted. The statements should be based on the percent complete of each subtask noted in the Itemized schedule.
- (b) The acceptance by the Contractor of the final payment of amounts withheld from the Engineer’s statements shall be and shall operate as a release to the County and the Engineer of all claims and of all liability to the Contractor for all things done or

## AGREEMENT

---

furnished in connection with this Work and for every act and neglect of the County and Engineer and others relating to or arising out of this Work.

- (c) The County reserves the right, at any time, to modify or change the Plans or Specifications as deemed necessary, and the Agreement shall not be invalidated thereby, however.
- (d) If the Contractor considers that he is being required to perform extra work for which no Change Order has been issued, then he shall serve Written Notice upon the County prior to such extra work is performed. On failure to serve this Notice, all rights of the Contractor to be paid therefore shall be forfeited.
- (e) As the work progresses in accordance with the contract and in a manner that is satisfactory to the County, the County hereby agrees to make payments to the Contractor therefore, based upon the proposal attached hereto and made part thereof as follows: The County shall once in each month and on such days as it may fix, determine the quantity of work completed and of material which has actually been put in place in accordance with the terms and conditions of the contract, during the preceding month, and compute the value thereof and pay to the Contractor the monies due as provided in §106-b of the General Municipal Law. No monthly payments shall be rendered unless the value of the work completed equals 10% of the contract amount or \$1,000 whichever is the lesser. Semimonthly payments may be rendered provided (a) the value of the work performed in two successive weeks is more than \$50,000 or (b) the Commissioner of Public Works deems it to be in the best interests of the County to do so. The Contractor shall not hold any retainage from any Subcontractor.

Article 6. CONTRACT DOCUMENTS. The Contract Documents which comprise the Contract between the Owner and the Contractor are attached hereto and made a part hereof and consist of the following:

- (a) The Proposal Booklet titled “**Replacement of New Albion Bridge #35 (B.I.N. 3322810) Tannery Street over Tributary South Branch Cattaraugus Creek**”.
- (b) Drawings and Plans
- (c) Any Modifications, including Addenda, duly delivered before the execution of this Agreement, and Change Orders incorporated after the Agreement is signed.
- (d) Bonds and Insurance instruments.

Article 7. MISCELLANEOUS.

- (a) Terms used in this Agreement shall have the same meanings which are defined in Section 101 of the NYSDOT Standard Specification, Construction and Materials of September 1, 2019 and all Addenda.

## AGREEMENT

---

- (b) The Contractor shall furnish a faithful performance surety bond on a form approved by the County in an amount equal to 100 percent of the Contract Price, and shall have as a surety thereon a surety company or companies authorized to do business in New York State. He likewise will furnish a Labor and Material Bond to guarantee the payment of all Labor and Materials supplied in connection with this Agreement.
- (c) Neither the County nor the Contractor shall, without the prior written consent of the other, assign or sublet in whole or in part his interest under any of the Contract Documents and, specifically, the Contractor shall not assign any monies due or to become due without the prior written consent of the County.
- (d) The County and the Contractor each binds himself, his partners, successors, assigns and legal representatives to the other party hereto in respect of all covenants, agreements and obligations contained in the Contract Documents.
- (e) The Contract Documents constitute the entire agreement between the County and the Contractor and may only be altered, amended or repealed by a duly executed written instrument.

Article 8. CONTRACTOR REPRESENTATIONS. The Contractor is experienced in the use and interpretation of plans and specifications such as those included in these Contract Documents. He has carefully reviewed these and all of the Contract Documents and has found them free of ambiguity and sufficient for bid purposes. He has based his bid solely on these documents not relying on any explanation or interpretation, oral or written, from any other source.

Article 9. CONTRACT PROVISIONS. The parties to the attached contract, license, lease, amendment or other agreement of any kind (hereinafter, "the contract" or "this contract") agree to be bound by the following clauses which are hereby made a part of the contract (the word "Contractor" herein refers to any part other than the County of Cattaraugus, the construction inspection firm, or Stantec Consulting Services Inc., whether a contractor, licensor, licensee, lessor, lessee or any other party). In the event of a conflict between the terms of the contract (including any and all amendments thereto and amendments thereof) and the terms of this Article, the terms of this Article shall control.

(a) Non-Assignment Clause

In accordance with Section 109 of the General Municipal Law, this contract may not be assigned by the Contractor, or its right, title or interest therein assigned, transferred, conveyed, sublet or otherwise disposed of without the previous consent, in writing, of the County and any attempts to assign the contract without the County's written consent are null and void.

(b) Workers' Compensation Benefits

In accordance with Section 108 of the General Municipal Law, this contract shall be void and of no force and effect unless the Contractor shall provide and maintain coverage during the life of this contract for the benefit of such employees as are required to be covered by the provisions of the Workers' Compensation Law.

## AGREEMENT

---

(c) Non-Discrimination Requirements

In accordance with Article 15 of the Executive Law (also known as the Human Rights Law) and all other State and Federal statutory and constitutional non-discrimination provisions, the Contract will not discriminate against any employee or applicant for employment because of race, creed, color, sex, national origin, age, disability or marital status. Furthermore, in accordance with Section 220-e of the Labor Law, if this is a contract for the construction, alteration or repair of any public building or public work or for the manufacture, sale or distribution of materials, equipment or supplies, and to the extent that this contract shall be performed within the State of New York, Contractor agrees that neither it nor its subcontractors shall, by reason of race, creed, color, disability, sex or national origin: (a) discriminate in hiring against any New York State citizen who is qualified and available to perform the work; or (b) discriminate against or intimidate any employee hired for the performance of work under this contract. If this is a building service contract as defined in Section 230 of the Labor Law, then, in accordance with Section 239 thereof, Contractor agrees that neither it nor its subcontractors shall, by reason of race, creed, color, national origin, age, sex or disability (a) discriminate in hiring against any New York State citizen who is qualified and available to perform the work; or (b) discriminate against or intimidate any employee hired for the performance of work under this contract. Contractor is subject to fines of \$50.00 per person per day for any violation of Section 220-e or Section 239 as well as possible termination of this contract and forfeiture of all monies due hereunder for a second or subsequent violation.

(d) Wage and Hours Provisions

If this is a public work contract covered by Article 8 of the Labor Law or a building service contract covered by Article 9 thereof, neither Contractor's employees nor the employees of its subcontractors may be required or permitted to work more than the number of hours or days stated in such statute, except as otherwise provided in the Labor Law and as set forth in prevailing wage and supplement schedules issued by the State Labor Department. Furthermore, Contractor and its subcontractors must pay at least the prevailing wage rate and pay or provide the prevailing supplements, including the premium rates for overtime pay, as determined by the State Labor Department in accordance with the Labor Law.

(e) Non-Collusive Bidding Requirement

In accordance with Section 103-d of the General Municipal Law, if this contract was awarded based upon the submission of bids, Contractor warrants, under penalty of perjury, that its bid was arrived at independently and without collusion aimed at restricting competition. Contractor further warrants that, at the time Contractor submitted its bid, an authorized and responsible person executed and delivered to the County a non-collusive bidding certification on the Contractor's behalf.

(f) Set-Off Rights

The County shall have all of its common law and statutory rights of set-off. These rights shall include, but not be limited to, the County's option to withhold for the

## AGREEMENT

---

purposes of set-off any monies due to the Contractor under this contract up to any amounts due and owing to the County with regard to this contract.

(g) Record-Keeping Requirement

The Contractor shall establish and maintain complete and accurate books, records, documents, accounts and other evidence directly pertinent to performance under this contract for a period of six (6) years following final payment or the termination of this contract, whichever is later, and any extensions thereto. The County Treasurer or County Administrator or any other person or entity authorized to conduct an examination, as well as the agency or agencies involved in this contract, shall have access to such books, records, documents, accounts and other evidential material during the contract term, extensions thereof and such (6) year period thereafter for the purposes of inspection, auditing and copying. "Termination of this contract", shall mean the later of completion of the work of the contract or the end date of the term stated in the contract.

(h) Governing Law

This contract shall be governed by the laws of the State of New York, except where the Federal supremacy clause requires otherwise.

(i) No Arbitration and Service of Process

Disputes involving this contract, including the breach or alleged breach thereof, may not be submitted to binding arbitration (except where statutorily authorized) but must, instead, be heard in a court of competent jurisdiction of the State of New York. Contractor hereby consents to service of process upon it by registered or certified mail, return receipt requested.

(j) Approval by County Legislature

This contract is subject to, and conditioned upon, approval by the Cattaraugus County Legislature.

(k) Postponement, Suspension, Abandonment or Termination of Contract

The County shall have the right to postpone, suspend, abandon or terminate this contract, and such actions shall in no event be deemed a breach of contract. In the event of any termination, postponement, delay, suspension or abandonment, the Contractor shall deliver to the County all data, reports, plans, or other documentation related to the performance of this contract, including but not limited to guarantees, warranties, as-built plans and shop drawings. In any of these events, the County shall make settlement with the Contractor upon an equitable basis as determined by the County which shall fix the value of the work which was performed by the Contractor prior to the postponement, suspension, abandonment or termination of this contract. This clause shall not apply to this contract if the contract contains other provisions applicable to postponement, suspension or termination of the contract.

## AGREEMENT

---

### (l) Indemnification

The Contractor shall indemnify and save harmless Cattaraugus County, its officers, and employees, the Engineer, Greenman-Pedersen, Inc. and Bergmann Associates Architects, Engineers, Landscape Architects & Surveyors, DPC from all suits, actions, or claims of any character brought because of any injuries or damage received or sustained by any person, persons, or property on account of the operations of such Contractor; or on account of or in consequence of any neglect in safeguarding the work; or through use of unacceptable materials in constructing the work; or because of any act of omission, neglect, or misconduct of the Contractor; or because of any claims or amounts recovered from any infringements of patent, trademark, or copyright; or from any claims on amounts arising or recovered under the Workers Compensation Law, or any other law, ordinance, order, or decree; and so much of the money due the Contractor under and by virtue of his Contract as shall be considered necessary by the County for such purpose, may be retained for the use of the County; or, in case no money is due, his surety may be held until such suit or suits, action or actions, claim or claims for injuries or damages as aforesaid shall have been settled and suitable evidence to that effect furnished to the County; except that money due the Contractor will not be withheld when the Contractor produces satisfactory evidence that he is adequately protected by public liability and property damage insurance.

The Contractor agrees to make no claim for damages for delay in the performance of this contract occasioned by any act or omission to act of the County, the Engineer, representative construction inspection firm, Stantec Consulting Services Inc. or any of its representatives, and the Contractor agrees that any such claim shall be fully compensated for by an extension of time to complete the performance of work as provided herein. This indemnification shall include all costs and disbursements incurred by the County, the Engineer, representative construction inspection firm and Stantec Consulting Services Inc. in defending any suit, including attorney's fees.

### (m) Conflict of Interest

- (1) The Contractor warrants that to the best of the Contractor's knowledge and belief, there are no relevant facts or circumstances which could give rise to an organizational conflict of interest, as herein defined, or that the Contractor has disclosed all such relevant information to the County.
- (2) An organizational conflict of interest exists when the nature of the work to be performed under this contract may, without some restriction on future activities, either result in an unfair competitive advantage to the Contractor or impair the Contractor's objectivity in performing the work for the County.
- (3) The Contractor agrees that if an actual or potential organizational conflict of interest is discovered after award, the Contractor will make a full disclosure in writing to the County. This disclosure shall include a description of actions which the Contractor has taken or proposes to take, after consultation with the County, to avoid, mitigate, or minimize the actual or potential conflict.

## AGREEMENT

---

- (4) The County may terminate this contract in whole or in part, if it deems such termination necessary to avoid an organizational conflict of interest. If the Contractor was aware of a potential organizational conflict of interest prior to award, or discovered an actual or potential conflict after award and did not disclose or misrepresented relevant information to the County, then the County may terminate the contract, or pursue such other remedies as may be permitted by law or this contract. The terms of Clause (k) of this Section or other applicable contract provision regarding termination shall apply to termination by the County pursuant to this clause.
- (5) The Contractor further agrees to insert in any subcontract hereunder, provisions which shall conform to the language of this clause.

(n) Requests for Payment

All requests for payment by the Contractor must be submitted on forms supplied and approved by the County. Each payment request must contain such items of information and supporting documentation as required by the County, and shall be all inclusive for the period of time covered by the payment request.

(o) Performance of Work Required

The Contractor agrees that during the performance of the work required pursuant to this Agreement, the Contractor and all officers, employees, agents or representatives working under the Contractor's direction shall strictly comply with all local, state or federal laws, ordinances, rules or regulations controlling or limiting in any way the performance of the work required by this Agreement. Furthermore, each and every provision of law required to be inserted in this Agreement shall be deemed so inserted, and the Agreement shall be read and enforced as if such provisions were so inserted.

The Contractor further agrees to insert in any subcontract hereunder, provisions which shall conform substantially to the language of this clause, including this paragraph.

(p) Independent Contractor Status

It is understood that the Contractor is an independent Contractor and shall not be considered an agent of the County nor shall any of the Contractor's employees or agents be considered sub-agents for the County. The final contract will be between the County and the Contractor and is not intended and shall not be construed to create the relationship of agent, servant, employee, partnership, joint venture, or association between County and Contractor. The employees and agents of one party are not the employees or agents of the other party for any purpose whatsoever. The Contractor understands and agrees that all persons performing work pursuant to the final contract are for purposes of workers' compensation liability, solely employees of the Contractor and not employees of the County. The Contractor shall be solely liable and responsible for furnishing any and all workers' compensation benefits to any person

AGREEMENT

as a result of any injuries arising from or connected with any work performed by or on behalf of the Contractor hereunder. The employees and agents of each party shall while on the premises of the other party, comply with all rules and regulations of the premises including, but not limited to security requirements. The Contractor agrees to comply with the non-discrimination employment policies as required by applicable state and federal laws and regulations regarding employment discrimination. The Contractor assures the County that in accordance with applicable law it does not, and agrees that it will not, discriminate in any manner on the basis of age, color, creed, national origin, race, religious belief, sexual preference, or handicap.

(q) No-Waiver

In the event that the terms and conditions of the Agreement are not strictly enforced by the County, such non-enforcement shall not act as or be deemed to act as a waiver or modification of this Agreement, nor shall such non-enforcement prevent the County from enforcing each and every term of this Agreement thereafter.

(r) Severability

If any provision of this Agreement is held invalid by a court of law, the remainder of this Agreement shall not be affected thereby if such remainder would then continue to conform to the laws of the State of New York.

IN WITNESS WHEREOF, the parties hereto have executed this AGREEMENT the day and year first above written.

Attest

\_\_\_\_\_

\_\_\_\_\_

By: County

Attest

\_\_\_\_\_

\_\_\_\_\_

By: Contractor



AGREEMENT

ACKNOWLEDGMENT OF COUNTY

STATE OF NEW YORK )SS  
COUNTY OF CATTARAUGUS )

On this \_\_\_\_\_ day of \_\_\_\_\_ 20\_\_\_\_, before me, the undersigned, a Notary Public in and for said State, personally appeared \_\_\_\_\_, personally known to me or proved to me on the basis of satisfactory evidence to be the individual whose name is subscribed to the within instrument and acknowledged to me that he executed the same in his capacity, and that by his signature on the instrument, the individual, or the person upon behalf of which the individual acted, executed the instrument.

\_\_\_\_\_  
Notary Public

ACKNOWLEDGMENT OF CONTRACTOR (OUTSIDE NEW YORK STATE)

STATE OF \_\_\_\_\_)SS:  
COUNTY OF \_\_\_\_\_)

On this \_\_\_\_\_ day of \_\_\_\_\_ 20\_\_\_\_, before me, the undersigned, a Notary Public in and for said State, personally appeared \_\_\_\_\_, personally known to me or proved to me on the basis of satisfactory evidence to be the individual(s) whose name(s) is subscribed to the within instrument and acknowledged to me that he/she/they executed the same in his/her/their capacity(ies), and that by his/her/their signature(s) on the instrument, the individual(s), or the person upon behalf of which the individual(s) acted, executed the instrument and that such individual made such appearance before the undersigned in the City/Town of \_\_\_\_\_ in State of \_\_\_\_\_.

(SEAL) \_\_\_\_\_  
Notary Public

AGREEMENT

ACKNOWLEDGMENT OF CONTRACTOR (WITHIN NEW YORK STATE)

STATE OF NEW YORK )SS:  
COUNTY OF \_\_\_\_\_)

On this \_\_\_\_\_ day of \_\_\_\_\_ 20\_\_\_\_, before me, the undersigned, a Notary Public in and for said State, personally appeared \_\_\_\_\_, personally known to me or proved to me on the basis of satisfactory evidence to be the individual(s) whose name(s) is subscribed to the within instrument and acknowledged to me that he/she/they executed the same in his/her/their capacity(ies), and that by his/her/their signature(s) on the instrument, the individual(s), or the person upon behalf of which the individual(s) acted, executed the instrument.

(SEAL)  
Notary Public

\_\_\_\_\_

**APPENDIX "A"**

**COUNTY OF CATTARAUGUS STANDARD INSURANCE REQUIREMENTS**

The insurance companies providing these coverages acknowledge that the Named Insured is entering into a contract with the County of Cattaraugus in which the Named Insured agrees to defend, hold harmless, and indemnify the County, its officials, employees, and agents against all claims resulting from work performed, material handled, and services rendered. In some circumstances it will be necessary to require alternate coverage and limits which will be defined in the bid specifications, contract, lease or agreement. The alternate coverage and limits should be evidenced on the certificate in lieu of the standards printed below.

**Minimum Coverage Limits are as Follows:**

	A	C	Ca	D	F	G	Ga
	Construction & Maintenance	Professional	Low Risk Professional	Property Leased to Others or Use of Facilities	Livery	All Purpose Public Entity, Concessionaire	Low Risk All Purpose Public Entity
<b>* ** COMMERCIAL GENERAL LIABILITY</b>	\$2,000,000 Agg. \$1,000,000 Occ.	\$2,000,000 Agg. \$1,000,000 Occ.	\$1,000,000 Agg. \$500,000 Occ.	\$2,000,000 Agg. \$1,000,000 Occ.	\$2,000,000 Agg. \$1,000,000 Occ.	\$2,000,000 Agg. \$1,000,000 Occ.	\$1,000,000 Agg. \$500,000 Occ.
Prem. - Ops	Include	Include	Include	Include	Include	Include	Include
Prods - Compl. Ops	Include	Include	Include	Include	Include	Include	Include
Indep. Contractor	Include	Include	Include	Include	Include	Include	Include
Contractual	Include	Include	Include	Include	Include	Include	Include
BF Property Damage	Include			Include			
X, C, U	Include						
Personal Injury	Include	Include	Include	Include	Include	Include	Include
Liquor Law				Include			
Host Liquor				Include			
<b>** AUTO LIABILITY</b>	\$1,000,000 CSL	\$1,000,000 CSL	\$1,000,000 CSL	\$1,000,000 CSL	\$1,000,000 CSL	\$1,000,000 CSL	\$1,000,000 CSL
Owned	Include	Include	Include	Include	Include	Include	Include
Hired	Include	Include	Include	Include	Include	Include	Include
Non-Owned	Include	Include	Include	Include	Include	Include	Include
<b>* ** EXCESS LIABILITY</b>	\$3,000,000	\$1,000,000		\$1,000,000	\$3,000,000	\$1,000,000	
<b>WORKERS' COMP.</b>	Statutory or Proof of Exemption	Statutory or Proof of Exemption	Statutory or Proof of Exemption	Statutory or Proof of Exemption	Statutory or Proof of Exemption	Statutory or Proof of Exemption	Statutory or Proof of Exemption
<b>EMPLOYER'S LIABILITY</b>	Unlimited	Unlimited	Unlimited	Unlimited	Unlimited	Unlimited	Unlimited
<b>*** PROFESSIONAL LIAB.</b>		\$3,000,000 Agg. \$1,000,000 Occ.	\$1,000,000 Agg. \$500,000 Occ.				

\* The Comprehensive/Commercial General Liability limits can be met by one or more policies, or in combination with an Excess and/or Umbrella Liability policy.

The COI must indicate if the coverage trigger in an 'Occurrence' form or a 'Claims-made' form.

All 'Claims-made' policies shall continue to provide evidence of coverage three (3) years after completion of work or product delivery.

\*\* Cattaraugus County MUST be named as Additional Insured for all acts of Named Insured pursuant to this contract.

\*\*\* Professional Liability policies are not required to have the County as Additional Insured.

***Each policy, as allowed by law, shall be endorsed stating that the contractor's insurers agree to waive any rights of subrogation against the County of Cattaraugus because of payments for any injury or damages arising out of work performed under this contract.***

**This Page Left Intentionally Blank**

# NOTICE OF AWARD

TO: \_\_\_\_\_  
\_\_\_\_\_  
\_\_\_\_\_

## Project Description:

Replacement of New Albion Bridge #35 (B.I.N. 3322810) Tannery Street over Tributary South Branch Cattaraugus Creek

The County has considered the Bid submitted by you for the above-described work in response to its Advertisement for Bid No. \_\_\_\_\_ opened \_\_\_\_\_.

You are hereby notified that your Bid has been accepted in the amount of \$

You are required by the General Provisions to execute the Agreement and furnish the required Contractor's Performance Bond and Payment Bond within ten (10) calendar days from the date of this Notice of Award.

If you fail to execute such Agreement and to furnish the Bonds within the ten (10) days from the date of this Notice, then the County will be entitled to consider all your rights arising out of Cattaraugus County's acceptance of your Bid as abandoned and as a forfeiture of your Bid Bond. Cattaraugus County will be entitled to such other rights as may be granted by law.

You are required to return an acknowledged copy of this Notice of Award to Cattaraugus

County. Dated this \_\_\_\_\_ day of \_\_\_\_\_ in the year

\_\_\_\_\_.

OWNER: Cattaraugus County

BY: \_\_\_\_\_

TITLE: \_\_\_\_\_

## ACCEPTANCE OF NOTICE

Receipt of the above NOTICE OF AWARD is hereby acknowledged by

\_\_\_\_\_

Dated this \_\_\_\_\_ day of \_\_\_\_\_ in the year

\_\_\_\_\_.

By: \_\_\_\_\_

Title: \_\_\_\_\_

**This Page Left Intentionally Blank**

# NOTICE TO PROCEED

**Date:**

**Project:** Replacement of New Albion Bridge #35 (B.I.N. 3322810) Tannery Street over Tributary South Branch Cattaraugus Creek

**TO:**

\_\_\_\_\_  
\_\_\_\_\_  
\_\_\_\_\_

You are hereby notified to commence work in accordance with the Agreement dated \_\_\_\_\_ on \_\_\_\_\_ or \_\_\_\_\_ after \_\_\_\_\_ . All work shall be completed on or before October 31, 2020 or 160 days after the commencement of in-stream work, whichever is earlier. The final payment shall be submitted within 45 calendar days of the completion of work.

You are required to return an acknowledged copy of this Notice of Proceed to Cattaraugus County

CATTARAUGUS COUNTY

Owner

By: \_\_\_\_\_

Title: \_\_\_\_\_

## ACCEPTANCE OF THIS NOTICE

Receipt of the above Notice to Proceed is hereby acknowledged by

\_\_\_\_\_

Dated this \_\_\_\_\_ day of \_\_\_\_\_ in the year

\_\_\_\_\_.

By: \_\_\_\_\_

Title: \_\_\_\_\_

**This Page Left Intentionally Blank**



# CERTIFICATE OF SUBSTANTIAL COMPLETION

**Date:**

**Project:** Replacement of New Albion Bridge #35 (B.I.N. 3322810) Tannery Street over Tributary South Branch Cattaraugus Creek

**TO:**

\_\_\_\_\_  
\_\_\_\_\_  
\_\_\_\_\_

The performed under this contract has been inspected by authorized representatives of the County, Contractor and Engineer and the Project was found to be substantially completed in accordance with the contract documents.

---

## DEFINITION OF SUBSTANTIAL COMPLETION

The date of substantial completion of a project or a specified area of a project is the date when the construction is sufficiently completed, in accordance with the contract documents, as modified by any change orders agreed to by the parties, so that the County can occupy or utilize the project or specified area of the project for the use it was intended.

---

A tentative list of items to be completed or corrected is attached hereto. This list may not be exhaustive, and the failure to include an item on it does not alter the responsibility of the Contractor to complete all the work in accordance with the contract documents

\_\_\_\_\_  
Engineer

By \_\_\_\_\_  
Authorized Representative

Date \_\_\_\_\_

The Contractor accepts the above Certificate of Substantial Completion and agrees to complete and correct the items on the tentative list with the time indicated.

\_\_\_\_\_  
Contractor

By \_\_\_\_\_  
Authorized Representative

Date \_\_\_\_\_

The County Accepts the project or specified area of the project as substantially complete and will assume full possession of the project or specified are of the project at \_\_\_\_\_ (time), on \_\_\_\_\_ (date).

Cattaraugus County

By \_\_\_\_\_  
Authorized Representative

Date \_\_\_\_\_

**This Page Left Intentionally Blank**